

SERVICE MANUAL

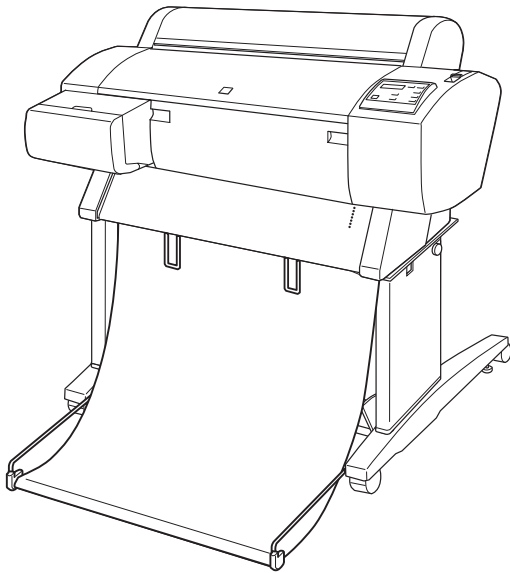

Color Large Format Inkjet Printer

EPSON Stylus Pro 7600/9600



EPSON®

SEIJ01017

Notice:

- All rights reserved. No part of this manual may be reproduced, stored in a retrieval system, or transmitted in any form or by any means, electronic, mechanical, photocopying, recording, or otherwise, without the prior written permission of SEIKO EPSON CORPORATION.
- The contents of this manual are subject to change without notice.
- All effort have been made to ensure the accuracy of the contents of this manual. However, should any errors be detected, SEIKO EPSON would greatly appreciate being informed of them.
- The above notwithstanding SEIKO EPSON CORPORATION can assume no responsibility for any errors in this manual or the consequences thereof.

EPSON is a registered trademark of SEIKO EPSON CORPORATION.

General Notice: Other product names used herein are for identification purpose only and may be trademarks or registered trademarks of their respective owners. EPSON disclaims any and all rights in those marks.

PRECAUTIONS

Precautionary notations throughout the text are categorized relative to 1) Personal injury and 2) damage to equipment.

DANGER Signals a precaution which, if ignored, could result in serious or fatal personal injury. Great caution should be exercised in performing procedures preceded by DANGER Headings.

WARNING Signals a precaution which, if ignored, could result in damage to equipment.

The precautionary measures itemized below should always be observed when performing repair/maintenance procedures.

DANGER

1. ALWAYS DISCONNECT THE PRODUCT FROM THE POWER SOURCE AND PERIPHERAL DEVICES PERFORMING ANY MAINTENANCE OR REPAIR PROCEDURES.
2. NO WORK SHOULD BE PERFORMED ON THE UNIT BY PERSONS UNFAMILIAR WITH BASIC SAFETY MEASURES AS DICTATED FOR ALL ELECTRONICS TECHNICIANS IN THEIR LINE OF WORK.
3. WHEN PERFORMING TESTING AS DICTATED WITHIN THIS MANUAL, DO NOT CONNECT THE UNIT TO A POWER SOURCE UNTIL INSTRUCTED TO DO SO. WHEN THE POWER SUPPLY CABLE MUST BE CONNECTED, USE EXTREME CAUTION IN WORKING ON POWER SUPPLY AND OTHER ELECTRONIC COMPONENTS.

WARNING

1. REPAIRS ON EPSON PRODUCT SHOULD BE PERFORMED ONLY BY AN EPSON CERTIFIED REPAIR TECHNICIAN.
2. MAKE CERTAIN THAT THE SOURCE VOLTAGES IS THE SAME AS THE RATED VOLTAGE, LISTED ON THE SERIAL NUMBER/RATING PLATE. IF THE EPSON PRODUCT HAS A PRIMARY AC RATING DIFFERENT FROM AVAILABLE POWER SOURCE, DO NOT CONNECT IT TO THE POWER SOURCE.
3. ALWAYS VERIFY THAT THE EPSON PRODUCT HAS BEEN DISCONNECTED FROM THE POWER SOURCE BEFORE REMOVING OR REPLACING PRINTED CIRCUIT BOARDS AND/OR INDIVIDUAL CHIPS.
4. IN ORDER TO PROTECT SENSITIVE MICROPROCESSORS AND CIRCUITRY, USE STATIC DISCHARGE EQUIPMENT, SUCH AS ANTI-STATIC WRIST STRAPS, WHEN ACCESSING INTERNAL COMPONENTS.
5. REPLACE MALFUNCTIONING COMPONENTS ONLY WITH THOSE COMPONENTS BY THE MANUFACTURE; INTRODUCTION OF SECOND-SOURCE ICs OR OTHER NON-APPROVED COMPONENTS MAY DAMAGE THE PRODUCT AND VOID ANY APPLICABLE EPSON WARRANTY.

About This Manual

This manual describes basic functions, theory of electrical and mechanical operations, maintenance and repair procedures of the printer. The instructions and procedures included herein are intended for the experienced repair technicians, and attention should be given to the precautions on the preceding page.

Manual Configuration

This manual consists of six chapters and Appendix.

CHAPTER 1.PRODUCT DESCRIPTIONS

Provides a general overview and specifications of the product.

CHAPTER 2.OPERATING PRINCIPLES

Describes the theory of electrical and mechanical operations of the product.

CHAPTER 3.TROUBLESHOOTING

Describes the step-by-step procedures for the troubleshooting.

CHAPTER 4.DISASSEMBLY / ASSEMBLY

Describes the step-by-step procedures for disassembling and assembling the product.

CHAPTER 5.ADJUSTMENT

Provides Epson-approved methods for adjustment.

CHAPTER 6.MAINTENANCE

Provides preventive maintenance procedures and the lists of Epson-approved lubricants and adhesives required for servicing the product.

APPENDIX Provides the following additional information for reference:

- Connector pin assignments
- Electric circuit boards components layout
- Electrical circuit boards schematics
- Exploded diagram & Parts List

Symbols Used in this Manual

Various symbols are used throughout this manual either to provide additional information on a specific topic or to warn of possible danger present during a procedure or an action. Be aware of all symbols when they are used, and always read NOTE, CAUTION, or WARNING messages.



Indicates an operating or maintenance procedure, practice or condition that is necessary to keep the product's quality.



Indicates an operating or maintenance procedure, practice, or condition that, if not strictly observed, could result in damage to, or destruction of, equipment.



May indicate an operating or maintenance procedure, practice or condition that is necessary to accomplish a task efficiently. It may also provide additional information that is related to a specific subject, or comment on the results achieved through a previous action.



Indicates an operating or maintenance procedure, practice or condition that, if not strictly observed, could result in injury or loss of life.

Revision Status

Revision	Date of Issue	Description
A	May 10, 2002	First release

Contents

Chapter 1 Product Description

1.1 Product Description	12	1.2.11.2 Accessories and Options for Stylus Pro 9600	29
1.1.1 Features	12	1.3 External View and Parts Names	30
1.1.2 Differences between Stylus Pro 7600 and Stylus Pro 9600	13	1.4 Operating Panel	31
1.2 Basic Specifications	14	1.4.1 Buttons and Functions	31
1.2.1 Print Specifications	14	1.4.1.1 Functions of Buttons	31
1.2.2 Character Specification	14	1.4.1.2 LEDs	32
1.2.3 Control Code	14	1.4.2 Indications on the Panel	33
1.2.4 Paper Feed	14	1.4.2.1 LED Indications in Normal Mode	33
1.2.5 Paper Specifications	15	1.4.2.2 LCD Indications in Normal Mode	34
1.2.5.1 Roll Paper	15	1.4.3 SelecType	35
1.2.5.2 Sheet	16	1.4.3.1 Outline	35
1.2.5.3 Special Paper	18	1.4.3.2 Panel Setting Menu Item	36
1.2.6 Mechanism Specifications	21	1.4.3.3 PG Setting	40
1.2.6.1 Printable Area	21	1.4.3.4 Page Lines	41
1.2.6.2 Paper Set Lever	22	1.4.3.5 Interface Select	41
1.2.6.3 Cutting Specification	22	1.4.3.6 Code Page Switching	41
1.2.6.4 Acoustic Noise	23	1.4.3.7 Roll Paper Margin	41
1.2.7 Electrical Specifications (TBD)	23	1.4.3.8 Detect Paper Width	42
1.2.8 Reliability	23	1.4.3.9 Detect Skew Error	42
1.2.8.1 Total Print Volume	23	1.4.3.10 Job Timeout Setting	42
1.2.8.2 Print Head Life	23	1.4.3.11 No margin print setting	43
1.2.8.3 Maintenance Tank Life	23	1.4.3.12 Cutter position adjustment	44
1.2.8.4 Cutter Life average	23	1.4.3.13 Auto margin refresh	44
1.2.8.5 Maintenance Parts (TBD)	23	1.4.3.14 Panel Setup Value Initialization	45
1.2.9 Ambient Conditions	24	1.4.3.15 Nozzle Check Pattern Printing	45
1.2.9.1 Temperature/Humidity	24	1.4.3.16 Status Printing	46
1.2.9.2 Vibration	24	1.4.3.17 Job Information Print	48
1.2.9.3 Shock	24	1.4.3.18 Firmware version	49
1.2.9.4 Surrounding Space	25	1.4.3.19 Printable pages of each ink cartridge	49
1.2.10 Overall Dimensions	26	1.4.3.20 Ink remaining	49
1.2.11 Accessories	28	1.4.3.21 Maintenance tank count	49
1.2.11.1 Accessories and Options for Stylus Pro 7600	28	1.4.3.22 Use counter	50
		1.4.3.23 Clear use counter	50
		1.4.3.24 Job history display	50

1.4.3.25 Job history clear	50
1.4.3.26 Total prints	50
1.4.3.27 Consumables life	51
1.4.3.28 Suction adjustment for paper setting and indicator display	53
1.4.3.29 Ink remaining indicator display	54
1.4.3.30 Job information	55
1.4.3.31 User Paper Setting	56
1.4.3.32 Power cleaning	60
1.4.3.33 Cutter Blade Replacement	60
1.4.3.34 Gap Adjustment (Bi-D Adjustment, Uni-D Adjustment)	60
1.4.3.35 BK ink cartridge replacement	64
1.4.4 Maintenance Mode 1	66
1.4.5 Maintenance Mode 2	70
1.4.6 Paper feeding adjustment conversion table	84
1.4.7 Firmware Reload	85
1.4.7.1 Reload from ROM-DIMM	85
1.4.7.2 Reload with F/W DOWNLOAD mode	85
1.4.7.3 Installation with service utility (F/W Update function)	85
1.4.7.4 Compulsory start F/W DOWNLOAD mode	85
1.4.8 Function to prevent irregular printing	86
1.4.9 Initialization	86
1.4.9.1 Hardware initialization	86
1.4.9.2 Software initialization	86
1.4.9.3 Panel initialization	86
1.4.10 Default Setup Values	87
1.4.10.1 Initial Setting for Operation	87
1.4.10.2 Ink Type Setting	87
1.4.10.3 MW Printing Adjustment / Setting Values and Printing Modes	88
1.4.10.4 Printing Mode Combination Table	89
1.5 Controller	90
1.6 Interfaces	91
1.6.1 Parallel Interface	91
1.6.1.1 Compatibility Mode	91
1.6.1.2 Nibble Mode	93
1.6.1.3 ECP Mode	94
1.6.2 USB interface	95
1.6.3 Optional Interface	96
1.6.4 Supplements	97
1.7 Optional Units and Consumables	98

1.7.1 Ink Cartridge	98
1.7.2 Cleaning cartridge	99
1.7.3 Draining cartridge	99
1.7.4 Maintenance Tank	99

Chapter 2 Operating Principles

2.1 Overview	101
2.2 Print Mechanism Components	102
2.2.1 Carriage (CR) Mechanism	103
2.2.2 Paper Feed Assembly	113
2.2.3 Cleaning Mechanism	115
2.2.4 Ink Supply Mechanism	117
2.2.5 Others	118
2.3 Outline of Control Circuit Board	119
2.4 Outline of Power Supply Circuit Board	120

Chapter 3 Troubleshooting

3.1 Outline	122
3.1.1 Introduction	122
3.2 Error Display	123
3.2.1 Errors	123
3.2.1.1 Error Indications on LCD	123
3.2.1.2 Warning Indications on LCD	124
3.2.1.3 Service Call (Fatal) Errors	125
3.2.2 Errors	126
3.2.2.1 Paper End/End of roll	126
3.2.2.2 Wrong paper source is selected on panel	126
3.2.2.3 Paper set lever is released during operation	126
3.2.2.4 Paper set lever is released	127
3.2.2.5 Paper Jam	127
3.2.2.6 Front Cover Open	127
3.2.2.7 Type-B I/F error	128
3.2.2.8 Paper cutting error	128
3.2.2.9 Paper Not Straight	128
3.2.2.10 Paper check error/Paper eject error (sheet)	129
3.2.2.11 Paper is too thick for cleaning	129
3.2.2.12 Not enough ink for cleaning	129

3.2.2.13 Ink-related Errors	130	3.2.4.28 PF ASIC ECU error (0001002B)	144
3.2.2.14 Defective ink cartridge	130	3.2.4.29 NVRAM error (00020000)	144
3.2.2.15 Ink lever released	130	3.2.4.30 SDRAM error (00020002)	145
3.2.2.16 Illegal ink cartridge	131	3.2.4.31 BOOT program SUM error (00020003)	145
3.2.2.17 Maintenance tank full	131	3.2.4.32 Flash memory SUM error (00020009)	145
3.2.2.18 No Maintenance tank	131	3.2.4.33 Program load error (0002000A)	145
3.2.2.19 Wrong IK designation	131	3.2.4.34 Internal memory shortage error (0002000B)	145
3.2.2.20 Fatal Error	131	3.2.4.35 Review error (0002000C)	146
3.2.3 Troubleshooting for Warning	132	3.2.4.36 CPU address error (load misalignment) (100000E0)	146
3.2.3.1 Ink Low	132	3.2.4.37 CPU address error (storage misalignment) (10000100)	146
3.2.3.2 Maintenance tank full warning	132	3.2.4.38 CPU reserve command code exception error (10000180)	146
3.2.3.3 Maintenance request	132	3.2.4.39 CPU slot illegal command exception error (100001A0)	146
3.2.4 Troubleshooting for Service Call Errors	134	3.2.4.40 CPU DMA address error (100005C0)	146
3.2.4.1 CR motor life (00000101)	134	3.2.4.41 CPU error (10000xxx)	146
3.2.4.2 PF motor encoder check error (00010000)	135	3.3 Troubleshooting Based on Your Printout	147
3.2.4.3 PF Motor out of step (00010001)	135	3.3.1 Dot Missing	147
3.2.4.4 PF motor overcurrent (00010002)	136	3.3.2 Uneven Printing/Poor Resolution	148
3.2.4.5 PF motor in-position time out (00010003)	136	3.3.3 Smudged or Marred Printout (Front)	148
3.2.4.6 CR motor encoder check error (00010004)	137	3.3.4 Smudged or Marred Printout (Reverse side)	149
3.2.4.7 CR motor out of step (00010005)	137	3.3.5 White or Black Banding in the carriage running direction	149
3.2.4.8 CR motor overcurrent (00010006)	138	3.3.6 Banding in the paper feed direction	150
3.2.4.9 CR motor in-position time-out (00010007)	138		
3.2.4.10 Servo interrupt watchdog time-out (00010008)	139		
3.2.4.11 System interrupt watchdog time-out (00010009)	139		
3.2.4.12 CR home position sensor error (0001000A)	139		
3.2.4.13 PF home position sensor error (0001000B)	139		
3.2.4.14 Head slide (PG) home position sensor error (0001000C)	140		
3.2.4.15 CR motor PWM output faulty (0001000F)	140		
3.2.4.16 PF motor PWM output faulty (00010010)	141		
3.2.4.17 Head driver (TG) temperature error (0001001B)	141		
3.2.4.18 CR servo parameter error (0001001D)	142		
3.2.4.19 PF servo parameter error (0001001E)	142		
3.2.4.20 CSIC reed/right error (00010020)	143		
3.2.4.21 Ink type error (setting on printer body side) (00010022)	143		
3.2.4.22 RTC analysis error (00010023)	143		
3.2.4.23 CSIC ROM communication error (00010025)	144		
3.2.4.24 RTC communication error (00010026)	144		
3.2.4.25 Head error (00010028)	144		
3.2.4.26 Unidentified NMI (00010029)	144		
3.2.4.27 CR ASIC ECU error (0001002A)	144		

Chapter 4 Disassembly & Assembly

4.1 Summary	152
4.1.1 Precautions	152
4.1.2 Tools	155
4.1.3 Screw List	155
4.1.4 Disassembly Flow	156
4.2 Removing the Panel Unit and Housing	158
4.2.1 Panel Unit	159
4.2.2 R Side Cover	160
4.2.3 L Side Cover	163
4.2.4 I/H Cover	164
4.2.5 H Top Cover	165
4.2.6 Rear Cover	166
4.2.7 Paper Guide L2	168
4.2.8 Roll Paper Cover	169
4.2.9 Front Cover	170

4.3 Disassembly and Assembly of Carriage (CR) Mechanism	171
4.3.1 Print Head	171
4.3.2 Damper ASSY	173
4.3.3 CR Board ASSY	174
4.3.4 Cutter Section	175
4.3.4.1 Cutter Holder ASSY	175
4.3.4.2 Cutter Solenoid	177
4.3.5 CR Encoder Sensor ASSY	178
4.3.6 P_EGDE Sensor ASSY	179
4.3.7 CR Motor ASSY	180
4.3.8 HEAD_SLIDE Sensor ASSY	182
4.3.9 CR_HP Sensor ASSY	183
4.3.10 CR Encoder Scale (Timing Fence)	184
4.4 Disassembly and Assembly of Paper Feed Mechanism	185
4.4.1 PF Motor	185
4.4.2 PF Encoder Sensor ASSY	186
4.4.3 Cautions when replacing the PF Loop Scale	187
4.4.3.1 Assembly Procedure for the PF Loop Scale ASSY	187
4.4.3.2 PF Loop Scale ASSY Affixing Procedure	188
4.4.4 Suction Fans	189
4.4.5 P_THICK Sensor/P_THICK Sensor_0.3 ASSY	190
4.4.6 P_REAR Sensor ASSY	191
4.5 Disassembly and Assembly of Ink Supply Mechanism	192
4.5.1 C472_SUB-B Board	192
4.5.2 I/H (Ink Holder) ASSY	193
4.5.3 Cover Sensor ASSY	197
4.6 Disassembly and Assembly of Cleaning Mechanism	198
4.6.1 Maintenance ASSY Removal	199
4.6.2 Pump Motor ASSY	200
4.6.3 Cap ASSY	200
4.6.4 Pump ASSY	201
4.6.5 Cleaner Head (Wiper)	203
4.6.6 Flushing Box ASSY	204
4.7 Disassembly and Assembly of Circuit Boards	205
4.7.1 Power Supply Board	205
4.7.2 AC Inlet	206
4.7.3 MAIN Board (C472 MAIN)	207
4.7.4 DIP Switch and Jumper Setting at Factory before Shipment	209

Chapter 5 Adjustment

5.1 Overview	211
5.1.1 Cautions	211
5.1.2 Adjustment Tools	211
5.1.3 Procedure for Adjustment Work	212
5.1.4 Adjustment Items	212
5.1.4.1 Print Head Adjustment	212
5.1.4.2 Main Board Adjustment	213
5.1.4.3 CR Motor Adjustment	214
5.1.4.4 PF Motor Adjustment	214
5.1.4.5 P_EDGE Sensor ASSY Adjustment	215
5.1.4.6 P_REAR Sensor ASSY Adjustment	215
5.1.4.7 P_THICK/P_THICK_0.3 Sensor ASSY Adjustment	215
5.1.4.8 CR Encoder Sensor ASSY Adjustment	215
5.1.4.9 Cover Sensor ASSY Adjustment	216
5.1.4.10 PF Encoder Sensor ASSY Adjustment	216
5.1.4.11 Cutter Solenoid ASSY or Paper Guide L Adjustment	217
5.1.4.12 Damper ASSY Adjustment	217
5.1.4.13 Release Sensor (I/H Lever) Adjustment	217
5.1.4.14 Battery	217
5.1.5 Parameter Backup	218
5.1.5.1 Parameter Backup Procedure	218
5.1.5.2 Work Procedure	218
5.1.5.3 Others	218
5.1.6 Firmware Reinstallation	219
5.1.6.1 Firmware Installation through ROM-DIMM	219
5.1.6.2 Firmware Installation through Interface	219
5.2 Self-diagnostic Function	220
5.2.1 Overview	220
5.2.1.1 How to Start Self-diagnostic Function	220
5.2.1.2 Functions of Keys during Self-diagnosis	220
5.2.1.3 Top Menu	221
5.2.2 Test	222
5.2.2.1 Version	223
5.2.2.2 Control Panel	223
5.2.2.3 Sensors	224
5.2.2.4 Encoder	225
5.2.2.5 Fan	225
5.2.2.6 Record	226

5.2.2.7 CSIC	227
5.2.2.8 Actuator	229
5.2.2.9 Actuator 2	229
5.2.3 Adjustment	230
5.2.3.1 Rear AD Adjustment	231
5.2.3.2 Edge AD Adjustment	232
5.2.3.3 Input Rank	233
5.2.3.4 Write D/A Value	236
5.2.3.5 Check Nozzle	237
5.2.3.6 Check Skew	238
5.2.3.7 Feed Correction + T&B Adjustment	239
5.2.3.8 Top & Bottom Adjustment	242
5.2.3.9 Rear Sensor Position	243
5.2.3.10 Platen Position (Sponge Position) Adjustment	244
5.2.3.11 Platen Position Checking	245
5.2.3.12 Head Slant Checking	246
5.2.3.13 Round Trip Print Position Adjustment (Bi-D Adjustment)	248
5.2.3.14 Parameter Copying	251
5.2.3.15 Bi-D2 Adjustment (PG=0.7mm)	251
5.2.3.16 Bi-D3 Adjustment (PG=2.1mm)	251
5.2.3.17 Round Trip Print Position (Bi-D Adjustment) Checking	252
5.2.3.18 Head Gap Adjustment (Uni-D Adjustment)	253
5.2.3.19 Test Pattern Printing	255
5.2.3.20 Clean Head	256
5.2.3.21 Counter Clear	257
5.2.4 Cleaning	259
5.2.5 Print	259
5.2.6 Parameter	260
5.2.6.1 Parameter Initialize	261
5.3 Mechanism Adjustment	263
5.3.1 Overview	263
5.3.2 CR Timing Belt Tension Adjustment	263
5.3.3 PF Timing Belt Tension Adjustment	264
5.3.4 P_THICK_0.3/P_THICK Sensor Mounting Plate Position Adjustment	265
5.3.5 Cover Sensor ASSY Mounting Position Adjustment	267
5.3.6 CR Encoder Sensor Mounting Position Adjustment	268
5.3.7 Cutter Positioning Adjustment	269
5.3.7.1 Paper Cutting Position Check	271
5.3.8 PF Encoder Sensor Installation Position Adjustment	272
5.3.9 USB ID Writing	273

Chapter 6 Maintenance

6.1 Overview	275
6.1.1 Periodic Maintenance Items and Product Life Information	276
6.1.2 Important Maintenance Items During Service Operations	279
6.2 Lubrication and Glue	280
6.2.1 Lubricating the CR Guide Rail	280

Chapter 7 Appendix

7.1 Connectors	282
7.2 Component Layout	285
7.3 Circuit Diagrams	286
7.4 Exploded Diagrams	292
7.5 ASP List (Parts List)	317
7.5.1 ASP List for Stylus Pro 7600	317
7.5.2 ASP List for Stylus Pro 9600	320

CHAPTER

1

PRODUCT DESCRIPTION

1.1 Product Description

1.1.1 Features

- Large Format
 - Stylus Pro 7600: Max. 24 inch paper width, A1+ size supported
 - Stylus Pro 9600: Max. 44 inch paper width, B0+ size supported
- Pigment ink / Dye ink
 - Pigment ink:
 - Users can select following blackish ink combinations.
 - Photo Black + Light Black
 - Matte Black + Light Black
 - Matte Black × 2
 - Dye ink:
 - 2 black ink cartridges are installed.
- High-speed Throughput
 - Stylus Pro 7600

Table 1-1. Throughput (Stylus Pro 7600)

EPSON media	Quality	Resolution (dpi)	Mode	Throughput (A1 printing time)
Plain Paper	Draft*1	360 × 180	Pseudo 4-color	2 min.
	Speed	360 × 360	Bi-D MF 240 cps	3/2 (BK×2*2) min.
Doubleweight Matte Paper	Speed	360 × 360	Bi-D M/W(POL) 240 cps	5 min.
	Quality	720 × 360	Bi-DFOL(POL)	9 min
Glossy Photo Paper Glossy Paper-Heavy Weight	Speed	720 × 360	Bi-D 22POL 240 cps	8 min.
	Quality	720 × 720	Bi-D 14POL 240 cps	13 min.
	Adv.Photo	1440 × 720	Bi-D 4-pass 240 cps	25 min
	Photo 2880	2880 × 1440	Bi-D 4-pass 190 cps	55 min

- Note *1: Color high-speed 360×180dpi mode (for POP, for all ink combinations of pigment/dye)
- *2: Black double-speed mode (for CAD, supported with FW), (It is switched automatically with 2 BK ink cartridge installation (dye/PPI) + M/W OFF)

■ Stylus Pro 9600

Table 1-2. Throughput (Stylus Pro 9600)

EPSON media	Quality	Resolution (dpi)	Mode	Throughput (A1 printing time)
Plain Paper	Draft*1	360 × 180	Pseudo 4-color	3.5 min
	Speed	360 × 360	Bi-D MF 240 cps	6/3.5 (BK×2*2) min.
Doubleweight Matte Paper	Speed	360 × 360	Bi-D M/W(POL) 240 cps	9 min.
	Quality	720 × 360	Bi-DFOL(POL)	17 min
Glossy Photo Paper Glossy Paper-Heavy Weight	Speed	720 × 360	Bi-D 22POL 240 cps	14 min
	Quality	720 × 720	Bi-D 14POL 240 cps	24 min
	Adv.Photo	1440 × 720	Bi-D 4-pass 240 cps	46 min
	Photo 2880	2880 × 1440	Bi-D 4-pass 190 cps	102 min

- Note *1: Color high-speed 360×180dpi mode (for POP, for all ink combinations of pigment/dye)
- *2: Black double-speed mode (for CAD, supported with FW), (It is switched automatically with 2 BK ink cartridge installation (dye/PPI) + M/W OFF)

- Super High Quality
 - High image quality with 7-color ink, 2880×1440 dpi, and minimum 4pl various layers.
- Low Running Cost
 - Independent for each color and 110 ml ink cartridge
 - Large capacity 220 ml ink cartridge as an option
- Paper Handling
 - Support various media.
 - Automatic roll paper cutter, manual cutter
 - Automatic loading (cut sheet)
 - Borderless print for right and left
- Compatibility with other LFPs
 - Commands are upper compatible with Stylus Pro 10000, Stylus Pro 10000CF, Stylus Pro 9000, Stylus Pro 9500, Stylus Pro 7000, and Stylus Pro 7500.
- The latest RIP technology
 - CPSI Pro software RIP

1.1.2 Differences between Stylus Pro 7600 and Stylus Pro 9600

Table 1-3. Differences between Stylus Pro 7600 and Stylus Pro 9600

	Item	Stylus Pro 7600	Stylus Pro 9600
Product Specifications	Maximum paper width	610mm (About 24 inches / A1+size supported)	1118m (About 44 inches / B0+size supported)
	RAM capacity	32MB (16Mbit×2) (IC600/601 = not mounted)	64MB (16Mbit×4)
Option	Take-up Reel Unit	Not supported (CN30 = not mounted)	Supported
	220 ml ink cartridge	Not supported	Supported

1.2 Basic Specifications

1.2.1 Print Specifications

- Printing: On-demand ink-jet
- Nozzle configuration:
 - Black: 192 nozzles (Black1, Black2, 96 nozzles each)
 - Color: 480 nozzles (cyan, magenta, light cyan, light magenta, yellow, 96 nozzles each)
 - Nozzle pitch: 0.141mm (1/180 inch) for each color
- Printing direction: Bi-direction with logic seeking (high-speed return, high-speed skip only)
- Printing speed and printable area
 - Character mode
 - Character quality: high quality
 - Character pitch: 10 cpi
 - Printable area:
 - Stylus Pro 7600: 237 characters (at 10 cpi) / 8,561 dots (360dpi)
 - Stylus Pro 9600: 437 characters (at 10 cpi) / 15,840 dots (360dpi)
 - Printing speed: 240 cps max.
 - Graphic Mode

Table 1-4. Graphics Modes (Stylus Pro 7600)

Horizontal resolution (dpi)	Printable area	Maximum number of printable dots	Printing speed
360	604 mm (24.16 inches)	8698	240 cps
720	604 mm (24.16 inches)	17395	240 cps
1440	604 mm (24.16 inches)	34790	240 cps
2880	604 mm (24.16 inches)	69581	190 cps

Table 1-5. Graphics Modes (Stylus Pro 9600)

Horizontal resolution (dpi)	Printable area	Maximum number of printable dots	Printing speed
360	1112 mm (43.78 inches)	15762	240 cps
720	1112 mm (43.78 inches)	31524	240 cps
1440	1112 mm (43.78 inches)	63048	240 cps
2880	1112 mm (43.78 inches)	126087	190 cps

1.2.2 Character Specification

- Character tables: 2 international character sets
 - PC 437 (US, Standard Europe)
 - PC 850 (Multilingual)

NOTE: This specification is not described in the user's manual.

- Typeface:
 - Bit map LQ font: EPSON Courier 10 cpi

NOTE: This specifications is not described in the user's manual.

1.2.3 Control Code

- Control code:
 - ESC/P Raster
 - ESC/P3

NOTE: This specifications is not described in the user's manual.

1.2.4 Paper Feed

- Paper feeding: Friction feed
- Line spacing: 1/6 inch or programmable at 1440 inch
- Paper path: Roll paper/manual
- Feed speed: 6.35 mm paper feed: 215 ± 10 msec (except front rush, back rush, and hold time)

1.2.5 Paper Specifications

1.2.5.1 Roll Paper

ACCEPTABLE PAPER

The printer accepts following plain paper and EPSON special paper. With any other paper, proper paper feeding and satisfactory print quality are not ensured.

- Paper Size

Table 1-6. Acceptable Roll Paper Sizes (Acceptable Paper)

Core	Model	Paper Size
2-inch core	Stylus Pro 7600	203mm ~ 610 mm (W) × ~ 45 m (H) *
	Stylus Pro 9600	203 mm ~ 1118 mm (W) × ~ 45 m (H) *
3-inch core	Stylus Pro 7600	203 mm ~ 610 mm (W) × ~ 202 m (H) *
	Stylus Pro 9600	203 mm ~ 1118 mm (W) × ~ 202 m (H) *

Note "*": Within roll size

- Roll Size
 - 2-inch core: 103 mm ext. diameter maximum for 1 roll setting
 - 3-inch core: 150 mm ext. diameter maximum for 1 roll setting
- Thickness: 0.08 mm ~ 0.50 mm

PLAIN PAPER

Trouble-free paper feeding is ensured only in the following specifications.

- Paper Size

Table 1-7. Acceptable Roll Paper Sizes (Plain Paper)

Core	Model	Paper Size
2-inch core	Stylus Pro 7600	203 mm ~ 610 mm (W) × ~ 45m (H) *
	Stylus Pro 9600	203 mm ~ 1118 mm (W) × ~ 45m (H) *
3-inch core	Stylus Pro 7600	203 mm ~ 610 mm (W) × ~ 202m (H) *
	Stylus Pro 9600	203 mm ~ 1118 mm (W) × ~ 202m (H) *

Note "*": Within roll size

- Roll Size
 - 2-inch core: 103 mm ext. diameter maximum for 1 roll setting
 - 3-inch core: 150 mm ext. diameter maximum for 1 roll setting
- Thickness: 0.08 ~ 0.11 mm
- Weight: 64 ~ 90gf/m²
- Type: Plain paper, Recycle paper

BORDERLESS PRINT ROLL PAPER

Borderless print for right and left is ensured for roll paper with any of the paper widths as specified in Figure 1-9 below.

NOTE: 300 mm, 400 mm, 500 mm and 600 mm are supported for Europe.

- Paper width

Table 1-8.

Stylus Pro 7600														
Stylus Pro 9600														
Japan	8"	210 mm	10"	-	12"	14"	-	16"	-	20"	-	24"	36"	44"
USA/Europe	8"	210 mm	10"	300 mm	12"	14"	400 mm	16"	500 mm	20"	600 mm	24"	36"	44"

- Note 1: Paper should have no wrinkles, tears, or folds and the surface should be smooth.
- 2: The force to remove the end of the roll paper from the core should be between 300 gf and 2000 gf
- 3: If core is used, a product-exclusive option (roll paper spindle 3 inch) is necessary.
- 4: It is used under normal conditions. (temperature 15°C ~ 25°C, humidity 40 ~ 60%RH)
- 5: Roll paper can be printed before paper comes out of the core.
(Reference: Remaining paper length is 30cm approx. when roll paper come out of the core.)
- 6: The mechanism clips print data out of over-printable area for borderless printing.

1.2.5.2 Sheet

ACCEPTABLE PAPER

The printer accepts following plain paper and special paper. With any other paper, proper paper feeding and satisfactory print quality are not ensured.

- Paper Size (The sizes indicated in bold italic are only for Stylus Pro 9600.)

Table 1-9. Acceptable Sheet Sizes (Acceptable Paper)

Paper Size	Size (W × H)	Paper Size	Size (W × H)
B0+*	1118 mm × 1580 mm	A4	210 mm × 297 mm
B0 *	1030 mm × 1456 mm	US E	34 × 44 in
B1 *	728 mm × 1030 mm	US D	22 × 34 in
B2	515 mm × 728 mm	US C	17 × 22 in
B3	364 mm × 515 mm	US B	11 × 17 in
B4	257 mm × 364 mm	44 × 36 in *	44 × 36 in
A0+ *	914 mm × 1292 mm	30 × 24 in	30 × 24 in
A0 *	841 mm × 1189 mm	Letter	8.5 × 11 in
A1+	24 × 36 in	B1 (wide) *	1030 × 728 mm
A1	594mm × 841 mm	8 × 10 in	8 × 10 in
A2	420 mm × 594 mm	30 cm × 45 cm	30 cm × 45 cm
A3+	329 mm × 483 mm	60 cm × 90 cm	60 cm × 90 cm
A3	297 mm × 420 mm		

Note " * ": Only for Stylus Pro 9600

- Thickness
 - 0.08 ~ 1.5 mm (paper length: 279 mm ~ 728 mm)
 - 0.08 ~ 0.5 mm (paper length: 728 mm ~ 1580 mm)

- NOTE 1:** Paper should have no wrinkles, tears, or folds and the surface should be smooth.
- 2:** 0.08 ~ 1.50 mm paper thickness is supported for long-edge insertion.
- 3:** The sizes indicated in bold italic are only for Stylus Pro 9600.

PLAIN PAPER

Proper feeding is ensured only in the following specifications.

- Paper Size: Same as above list
- Thickness: 0.08 ~ 0.11 mm
- Weight: 64 ~ 90 gf/m²
- Type: Plain paper, Recycle paper

- NOTE 1:** Paper is fed short-edge first.
- 2:** Paper should have no wrinkles, tears, or folds and the surface should be smooth.
- 3:** It is used under normal conditions (temperature 15 ~ 25°C, humidity 40 ~ 60%RH)
- 4:** 300mm, 400mm, 500mm, 600mm are supported for Europe.
- 5:** Mechanism clips print data out of over-printable area for borderless print.

BORDERLESS PRINT WIDTH

Borderless print for right and left is assured with following paper width. *4

- Paper width

Table 1-10.

Stylus Pro 7600														
Stylus Pro 9600														
Japan	8"	210 mm	10"	-	12"	14"	-	16"	-	20"	-	24"	36"	44"
USA/Europe	8"	210 mm	10"	300 mm	12"	14"	400 mm	16"	500 mm	20"	600 mm	24"	36"	44"



Description of units of measure	
cpi:	characters per inch
dpi:	dots per inch
cps:	characters printed per second (at 10 cpi) 1 cps = 2.54 mm/s
ips:	travel in inches per second 1 ips = 25.4 mm/s
G:	Gravity
General ambient conditions:	
	Temperature 15°C ~ 25°C
	Humidity 40% ~ 60%

1.2.5.3 Special Paper

□ Roll (pigment)

Table 1-11. Availability with Special Paper (Pigment)

Roll / Pigment			Characteristic					Media Size															
			Black INK			core [™] spindle	Paper thickness (mm)	Auto cut	Borde rless	8"	210 mm	10"	30 cm	12"	14"	40 cm	16"	50 cm	20"	22"	60 cm	24"	36"
Name	Japan	USA/ Europe /Asia	MK ×2	MK +LK	PK +LK							203	210	254	300	305	356	400	406	500	508	560	600
Doubleweight Matte Paper	○	○	●	●	○	2	0.21	⊙		-	-	-	-	-	-	-	-	-	-	-	⊙	⊙	⊙
Glossy Paper - Photo Weight	○	○			○	2	0.22	⊙		-	-	-	-	-	-	-	-	-	⊙	-	-	⊙	⊙
Glossy Film	○	○			○	2	0.13	⊙		-	-	-	-	-	-	-	-	-	-	-	⊙	⊙	⊙
Premium Glossy Photo Paper	○	○			○	2	0.18	⊙		-	-	-	-	-	-	-	-	-	-	-	⊙	⊙	⊙
Premium Semigloss Photo Paper	○	○			○	2	0.18	⊙		-	-	-	-	-	-	-	-	-	-	-	⊙	⊙	⊙
Photo Glossy Paper / Photo Grade Glossy Paper	○	○			○	2	0.17	⊙		-	-	-	-	-	-	-	-	-	-	-	⊙	⊙	⊙
Photo Semigloss Paper / Photo Grade Semigloss Paper	○	○			○	2	0.18	⊙		-	-	-	-	-	-	-	-	-	-	-	⊙	⊙	⊙
Premium Glossy Photo Paper (250)	○	○			○	3	0.26	⊙	⊙	-	-	-	-	-	-	-	-	-	-	-	⊙	⊙	⊙
Premium Semigloss Photo Paper (250)	○	○			○	3	0.26	⊙	⊙	-	-	-	-	-	-	-	-	-	-	-	⊙	⊙	⊙
Premium Semimatte Photo Paper (250)	○	○			○	3	0.26	⊙	⊙	-	-	-	-	-	-	-	-	-	-	-	⊙	⊙	⊙
Premium Luster Photo Paper	○	○			○	3	0.26	⊙	⊙	-	-	⊙	⊙	⊙	⊙	⊙	⊙	⊙	-	⊙	⊙	⊙	⊙
Watercolor Paper - Radiant White	○	○		○	○	3H	0.29	⊙		-	-	-	-	-	-	-	-	-	-	-	⊙	⊙	⊙
Smooth Fine Art Paper (Roll)		○		○	○	3H	0.37			-	-	-	-	-	-	-	-	-	-	-	⊙	⊙	⊙
Textured Fine Art Paper (Roll)	○	○		○	○	3H	0.37			-	-	-	-	-	-	-	-	-	-	-	⊙	⊙	⊙
Canvas		○		○	○	2	0.46			-	-	-	-	-	-	-	-	-	-	-	⊙	⊙	⊙
Backlight Film	○				○	2	0.13	⊙		-	-	-	-	-	-	-	-	-	-	-	⊙	⊙	⊙
Backlight Film (USA / Europe)		○			○	2	0.18			-	-	-	-	-	-	-	-	-	-	-	⊙	⊙	⊙
Heavyweight Polyester Banner	○	○		●	○	2	0.28			-	-	-	-	-	-	-	-	-	-	-	⊙	⊙	⊙
Enhanced Synthetic Paper	○	○	●	●	○	2H	0.12	⊙		-	-	-	-	-	-	-	-	-	-	-	⊙	⊙	⊙
Adhesive Enhanced Synthetic Paper	○	○	●	●	○	2H	0.17	⊙		-	-	-	-	-	-	-	-	-	-	-	⊙	⊙	⊙
Tyvek Brillion		○	●	●	○	2	0.24	⊙		-	-	-	-	-	-	-	-	-	-	-	⊙	⊙	⊙
Adhesive Vinyl		○	●	●	○	2	0.33			-	-	-	-	-	-	-	-	-	-	-	⊙	⊙	⊙
Enhanced Matte Paper	○	○		○	○	3	0.25	⊙		-	-	-	-	-	-	-	-	-	-	-	⊙	⊙	⊙
Semiglossy 2	TBD	TBD			○	2	TBD	⊙		-	-	-	-	-	-	-	-	-	-	-	⊙	⊙	-
Semiglossy 4		○			○	2	TBD	⊙		-	-	-	-	-	-	-	-	-	-	-	⊙	⊙	-
Dupont / EPSON Semi - Gloss Proofing Paper - A		○			○	2	0.20			-	-	-	-	-	-	-	-	-	-	-	⊙	⊙	-

Note : Symbol ⊙: Assured, ○: Supported, ●: Supported conditionally, ×: Not supported, 2H/3H: High tension spindle

□ Roll (dye)

Table 1-12. Availability with Special Paper (Dye)

Roll / Dye			Characteristic				Media Size													
			core" spindle	Paper thickness (mm)	Auto cut	Borderless	8"	210 mm	10"	30cm	12"	14"	40cm	16"	50cm	20"	22"	60cm	24"	36"
Name	Japan	USA/ Europe/ Asia					203	210	254	300	305	356	400	406	500	508	560	600	610	914
Presentation Matte Paper			○	○	2	0.20	○		-	-	-	-	-	-	-	-	-	⊙	⊙	⊙
Semigloss Photo Paper (Asia / Europe) Semi Gloss Paper - Heavy Weight (US)			○	○	2	0.21	○		-	-	-	-	-	-	-	-	-	⊙	⊙	⊙
Glossy Photo Paper (Asia / Europe) Glossy Paper - Heavy Weight (US)			○	○	2	0.23	○		-	-	-	-	-	-	-	-	-	⊙	⊙	⊙
Doubleweight Matte Paper				○	2	0.21	○		-	-	-	-	-	-	-	-	-	⊙	⊙	⊙
Glossy Film			○	○	2	0.13	○		-	-	-	-	-	-	-	-	-	⊙	⊙	⊙
Photo Grade Glossy Paper (Asia / Europe) Photo Glossy Paper (US)				○	2	0.17	○		-	-	-	-	-	-	-	-	-	⊙	⊙	⊙
Photo Grade Semigloss Paper (Asia / Europe) Photo Semigloss Paper (US)				○	2	0.18	○		-	-	-	-	-	-	-	-	-	⊙	⊙	⊙
Heavyweight Polyester Banner			○	○	2	0.28			-	-	-	-	-	-	-	-	-	⊙	⊙	⊙
RC 10mil Glossy Paper (TBD)			TBD	○	3	0.26	○		-	-	-	-	-	-	-	-	-	⊙	⊙	⊙
RC 10mil Semigloss Paper (TBD)			TBD	○	3	0.26	○		-	-	-	-	-	-	-	-	-	⊙	⊙	⊙
Premium Luster Photo Paper			TBD	○	3	0.26	○	⊙	-	-	⊙	⊙	⊙	⊙	⊙	⊙	⊙	⊙	⊙	⊙
Dupont / EPSON Commercial Proofing Paper				○	2	0.21	○		-	-	-	-	-	-	-	-	-	⊙	⊙	-
Dupont / EPSON Commercial Matte Proofing Paper				○	2	0.24	○		-	-	-	-	-	-	-	-	-	⊙	⊙	-
Dupont / EPSON Publication Proofing Paper				○	2	0.24	○		-	-	-	-	-	-	-	-	-	⊙	⊙	-

Note : Symbol ⊙: Assured, ○: Supported, ●: Supported conditionally, ×: Not supported, 2H/3H: High tension spindle

Note *1: Assured with Uni-D print.

*2: Paper is fed short-edge first.

*3: Paper should have no wrinkles, tears, or folds and the surface should be smooth.

*4: It is used under normal conditions (temperature 15°C ~ 25°C, humidity 40% ~ 60%RH)

*5: Paper feeding and print quality with borderless print is not assured on paper which is not assured for borderless print.

*6: Borderless print is not assured with sheet.

□ Sheet (pigment)

Table 1-13. Availability with Sheets (Pigment)

Sheet / Pigment			Characteristic				Media size											
			Black INK			Paper thickness (mm)	A4	LTR	A3	B	Super A3/B	A2	C	B2	A1	D	24"×30"	30"×40"
Name	Japan	USA/ Europe/ Asia	MK ×2	MK +LK	PK +LK		210×297	216×279	297×420	279×432	329×483	420×594	432×559	515×728	728×1030	559×864	610×762	762×1016
Glossy Paper - Photo Weight	○	○			○	⊙	⊙	⊙	⊙	⊙	-	-	-	-	-	-	-	-
Watercolor Paper - Radiant White	○	○		○	○	-	-	-	-	⊙	-	-	-	-	-	-	-	-
Smooth Fine Art Paper		○		○	○	0.67	-	-	-	-	-	-	-	-	-	⊙	-	⊙
Textured Fine Art Paper	TBD	○		○	○	0.67	-	-	-	-	-	-	-	-	-	⊙	-	⊙
Enhanced Matte - Poster Board	○	○		○	○	1.3			-	-	-	-	-	-	-	⊙	⊙	-

Note : Symbol ⊙: Assured, ○: Supported, ●: Supported conditionally, ×: Not supported, 2H/3H: High tension spindle

□ Sheet (dye)

Table 1-14. Availability with Sheets (Dye)

Sheet / Dye			Characteristic	Media size											
				Paper thickness	A4	LTR	A3	B	Super A3/B	A2	C	B2	A1	D	B1"
Name	Japan	USA/Europe /Asia			210×297	216×279	297×420	279×432	329×483	420×594	432×559	515×728	728×1030	559×864	728×1030
Glossy Photo paper	○	○		⊙	⊙	⊙	⊙	⊙	⊙	-	-	-	-	-	-
Photo Quality Inkjet Paper	○	○		⊙	⊙	⊙	⊙	⊙	⊙	⊙	-	-	-	-	-
Glossy Film	○	○		⊙	⊙	⊙	⊙	⊙	⊙	-	-	-	-	-	-
Semigloss Paper - Poster Board		○		-	-	-	-	-	-	-	⊙	-	-	⊙	

Note : Symbol ⊙: Assured, ○: Supported, ●: Supported conditionally, ×: Not supported, 2H/3H: High tension spindle

Note *1: Assured with Uni-D print.

*2: Paper is fed short-edge first.

*3: Paper should have no wrinkles, tears, or folds and the surface should be smooth.

*4: It is used under normal conditions (temperature 15°C~25°C, humidity 40%~60%RH)

1.2.6 Mechanism Specifications

1.2.6.1 Printable Area

Table 1-15. Printable Area

Item	Roll paper /Sheet	Model	Dimension
PW (Paper width)	Roll paper	Stylus Pro 7600	203 mm ~ 610 mm
		Stylus Pro 9600	203 mm ~ 1118 mm
	Sheet	Stylus Pro 7600	203 mm ~ 610 mm
		Stylus Pro 9600	203 mm ~ 1118 mm
PL (Paper length)	Roll paper	Stylus Pro 7600/Stylus Pro 9600	Max. 202m
	Sheet	Stylus Pro 7600/Stylus Pro 9600	279 mm ~ 1580 mm
TM (Top margin)	Roll paper	Stylus Pro 7600/Stylus Pro 9600	3 mm/15 mm
	Sheet	Stylus Pro 7600/Stylus Pro 9600	3 mm
BM (Bottom margin)	Roll paper	Stylus Pro 7600/Stylus Pro 9600	3 mm/15 mm
	Sheet	Stylus Pro 7600/Stylus Pro 9600	14 mm
LM (Left margin)	Roll paper	Stylus Pro 7600/Stylus Pro 9600	0 mm/3 mm/15 mm
	Sheet	Stylus Pro 7600/Stylus Pro 9600	0 mm/3 mm
RM (Right margin)	Roll paper	Stylus Pro 7600/Stylus Pro 9600	0 mm/3 mm/15 mm
	Sheet	Stylus Pro 7600/Stylus Pro 9600	0 mm/3 mm

- The printer detects paper width when paper is set. (If paper width detection setting is OFF, it does not detect paper width.)
- It does not print the image beyond the detected paper width or the printable area specified by paper size setting. (It may print on the platen if paper width detection setting is OFF.)
- Margins of roll paper can be changed on the panel as follows;
 Top/bottom 15 mm, left/right 3 mm
 Top/bottom/left/right 3 mm
 Top/bottom/left/right 15 mm

NOTE: Under special conditions, it is possible to set right and left margin (LM, RM) to 0.

- For borderless print, right and left margins are 3mm each because skew detection limit is 3mm. If the distance from the paper edge to the platen (sponge width) is less than 3mm, the maximum surplus print quantity without ink discharge onto the platen (0mm~3mm) is printable area.

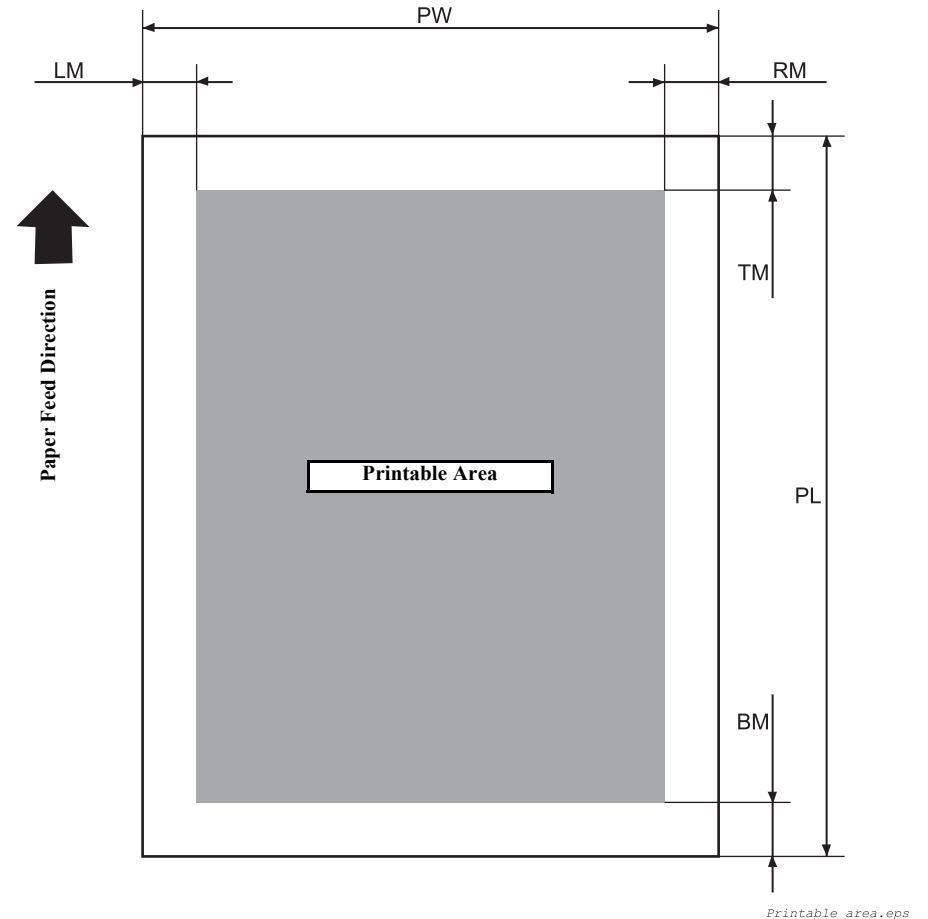

Figure 1-1. Printable Area

1.2.6.2 Paper Set Lever

Table 1-16. Paper Set Lever

Lever Position	Description
In the rear	Position for paper setting (You can set paper.)
In the front	Ready-to-print position (Paper is held with the paper holder.)

1.2.6.3 Cutting Specification

There are two methods to cut roll paper, automatic and manual cutting.



Do not use the auto cutting function with any paper for which auto cutting is prohibited; otherwise, the head would be damaged.

AUTOMATIC CUTTING OF ROLL MEDIA

Automatic cutting under the following conditions can only be performed on the approved media.

- Mechanical conditions
 - Distance between cut position and paper setting position: L0=167mm
 - Distance between cut position and cutter mark: L1= 44mm
 - Minimum cut length (same as paper edge waiting position): L2=030mm

Table 1-17. Cutting Conditions and Cutting Methods

Cut condition	Cut method
Initial cut (Cut with pushing “Cut/Eject” button after paper is set, and set lever is pushed down.)	Paper is fed for L1 length and cut in 4 steps. (50cps)
Cut after print completed by driver	4-step cut (200cps) When paper is shorter than L2, it is cut after feeding L2.
Initial cut during printing	Cut during printing is not allowed with this printer. (Product specification)
Initial cut during normal waiting status	Paper is fed for L1 length and cut in 4 steps. (50cps)
Initial cut with Auto cut ON after print with Auto cut OFF.	4-step cut (200cps), when paper is longer than L2. 4-step cut (50cps) after feeding L2, when paper is shorter than L2.
Cut with Paper width detection OFF	3-step cut always (100cps fixed)

Note : Cutting pressure at high speed can be changed.
 Cutting pressure at low speed is “Duty: 45%” fixed.
 Paper edge waiting position is fed L2 for initial cut.

MANUAL CUTTING OF ROLL PAPER

Manual cutting is performed by the following procedure.

1. Select “Roll Cutter Off” on the panel.
2. Press “Cut/ Eject” button.
3. Paper is automatically fed toward the cutter guide, and printer becomes Off-line. “Pause” is indicated on the LCD panel.
4. Adjust cutting position with “Paper Feed +/-” button if necessary.
5. Slide the cutter along the cutter guide to cut the paper.
6. After cutting, release the printer from the pause status by pressing the “Pause” button. Then paper is fed backward and printer enters on-line.



For manual cutting of roll paper, use the manual cutter available as an option.

1.2.6.4 Acoustic Noise

- Level: Approx. 50dB(A) (According to ISO 7779)

1.2.7 Electrical Specifications (TBD)

- Rated voltage: AC 100 ~ 240V
- Input voltage range: AC 90 ~ 264V
- Rated frequency range: 50 ~ 60Hz
- Input frequency range: 49 ~ 61Hz
- Rated current:
 - Stylus Pro 7600: 1.0A/100-120v, 0.5A/220-240v
 - Stylus Pro 9600: 1.0A/100-120v, 0.5A/220-240v
- Power consumption:
 - Operation status: Stylus Pro 7600 50W
Stylus Pro 9600 55W
 - Waiting status: Less than 15W (shifting time: 15 minutes)
 - Power OFF: Less than 0.7W
- Insulation resistance: More than 10M ohms
(between AC line and chassis, DC 500V)
- Dielectric strength: AC 1.0kV rms 1min.
AC1.2kV rms 1 sec.
(between AC line and chassis)
- Leakage: Less than 0.25mA
- International Energy Star Program Compliant:
(Complies with the power supply harmonic control guideline)

1.2.8 Reliability

1.2.8.1 Total Print Volume

- Stylus Pro 7600: 50,000 pages, 6.5million pass approx. (A1, 360×360 M/F, Bi-D)
- Stylus Pro 9600: 20,000 pages, 5million pass approx. (B0, 360×360 M/F, Bi-D)

1.2.8.2 Print Head Life

- Monochrome: 28billion shot / nozzle
- Color: 28billion shot / nozzle

1.2.8.3 Maintenance Tank Life

- Stylus Pro 7600: 11,000 pages approx.
(A1, plain paper, Speed mode, continuous print)
- Stylus Pro 9600: 5,000 pages approx.
(B0, plain paper, Speed mode, continuous print)

1.2.8.4 Cutter Life average

Table 1-18. Cutter life average

Paper Type	Stylus Pro 7600 For 24-inch standard roll paper, 3-step cutting	Stylus Pro 9600 For 44-inch standard roll paper, 3-step cutting
Coated paper	Approx. 2000 sheets	Approx. 2000 sheets
Film	Approx. 1000 sheets	Approx. 1000 sheets

1.2.8.5 Maintenance Parts (TBD)

- RTC backup battery: (TBD)
- Cleaning unit life average
(Cap assembly, Pomp assembly, Flushing box, Wiper)
 - Stylus Pro 7600: 18,000 pages approx.
(A1, plain paper, Speed mode, continuous print)
 - Stylus Pro 9600: 8,000 pages approx.
(B0, plain paper, Speed mode, continuous print)
- Ink absorbent sponge for right/left borderless print: (TBD)

1.2.9 Ambient Conditions

1.2.9.1 Temperature/Humidity

Table 1-19. Temperature/Humidity

Condition	Temperature*1	Humidity*2
During operation	10 ~ 35°C	20 ~ 80%
During storage	-20 ~ 40°C	20 ~ 85%
During transport	-20 ~ 60°C	5 ~ 85%

Note *1: 120 hours max. at 60°C, one month max. at 40°C

*2: No condensation. These values are applicable only within the range as shown below.

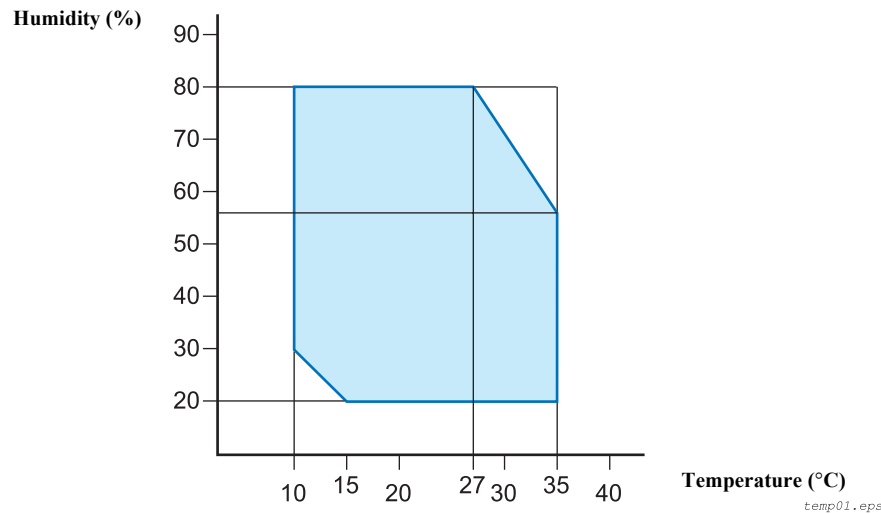

Figure 1-2. Environmental Conditions: Temperature/Humidity

1.2.9.2 Vibration

- During operation: 0.15G, 10 ~ 55Hz X,Y and Z directions
- During storage: 0.50G, 10 ~ 55Hz X,Y and Z directions

1.2.9.3 Shock

- During operation: 1G, 1ms max. X,Y and Z directions
- During storage: 2G, 2ms max. X,Y and Z directions

NOTE 1: For storage, check that the print head is capped.

2: Before transportation, check that the print head is capped, remove the ink cartridges, and close the ink cartridge cover.

3: If the power to the printer is OFF with the printer head uncapped, turn the power ON with the ink cartridges installed. Then wait until capping is completed, and turn the power OFF.

4: If the printer is left standing at temperature of -15°C or below, the ink in the print head and ink cartridges will freeze. If the ink is frozen, leave the printer standing at temperature of 25°C for more than three hours before its use.

1.2.9.4 Surrounding Space

Provide the printer with an enough surrounding space to ensure proper installation of accessories and replacement of consumables and easy work for daily maintenance.

- From the front of the printer: 60 cm or more
- From the rear and both sides of the printer: 15 cm or more

- When Stylus Pro 7600 is not equipped with the dedicated stand:
 Stylus Pro 7600 ejects paper downward. To prevent the ejected paper from being obstructed, install the printer on a table or desk 60 to 80 cm high above the floor and provide the printer with a 60 cm or more space in front. In doing so, locate the front rubber feet of the printer close to the front end of the table or the desk.

**Stylus Pro 7600
(without stand)**

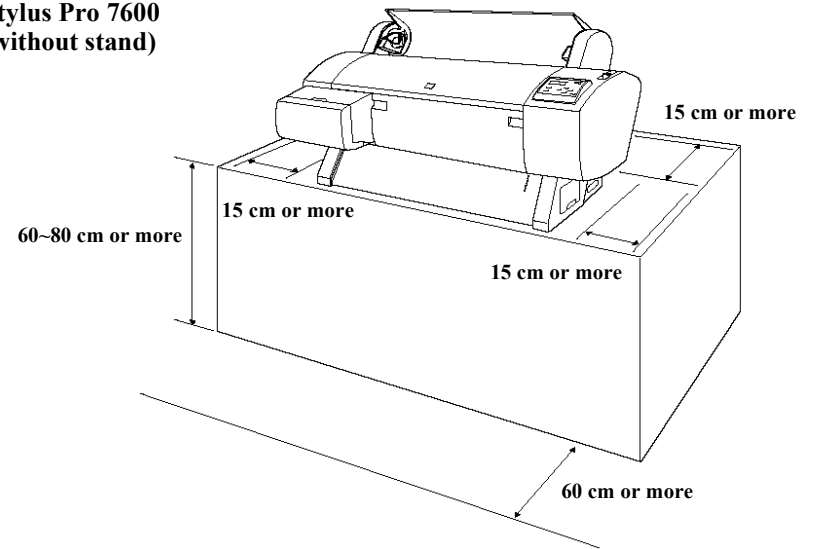

**Stylus Pro 7600 (with stand)/
Stylus Pro 9600**

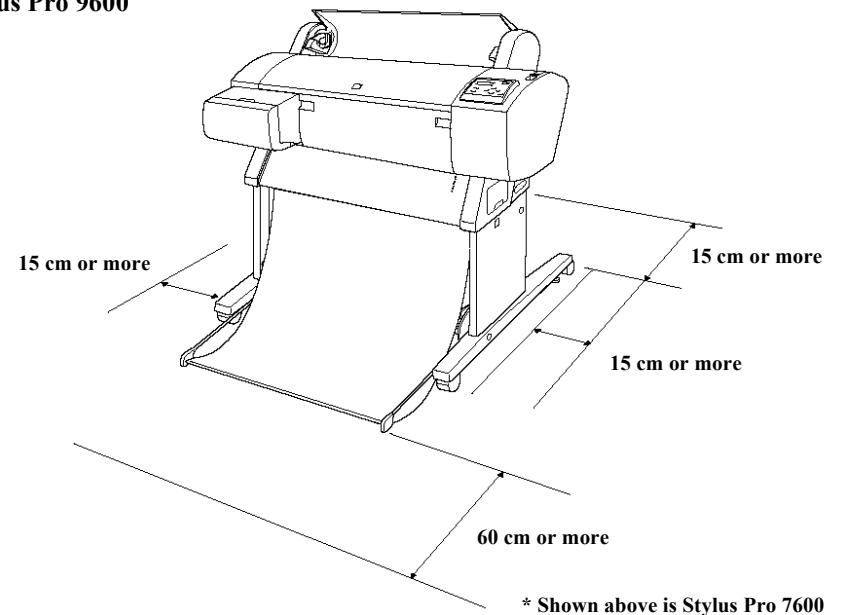

* Shown above is Stylus Pro 7600

Figure 1-3. Surrounding Space

1.2.10 Overall Dimensions

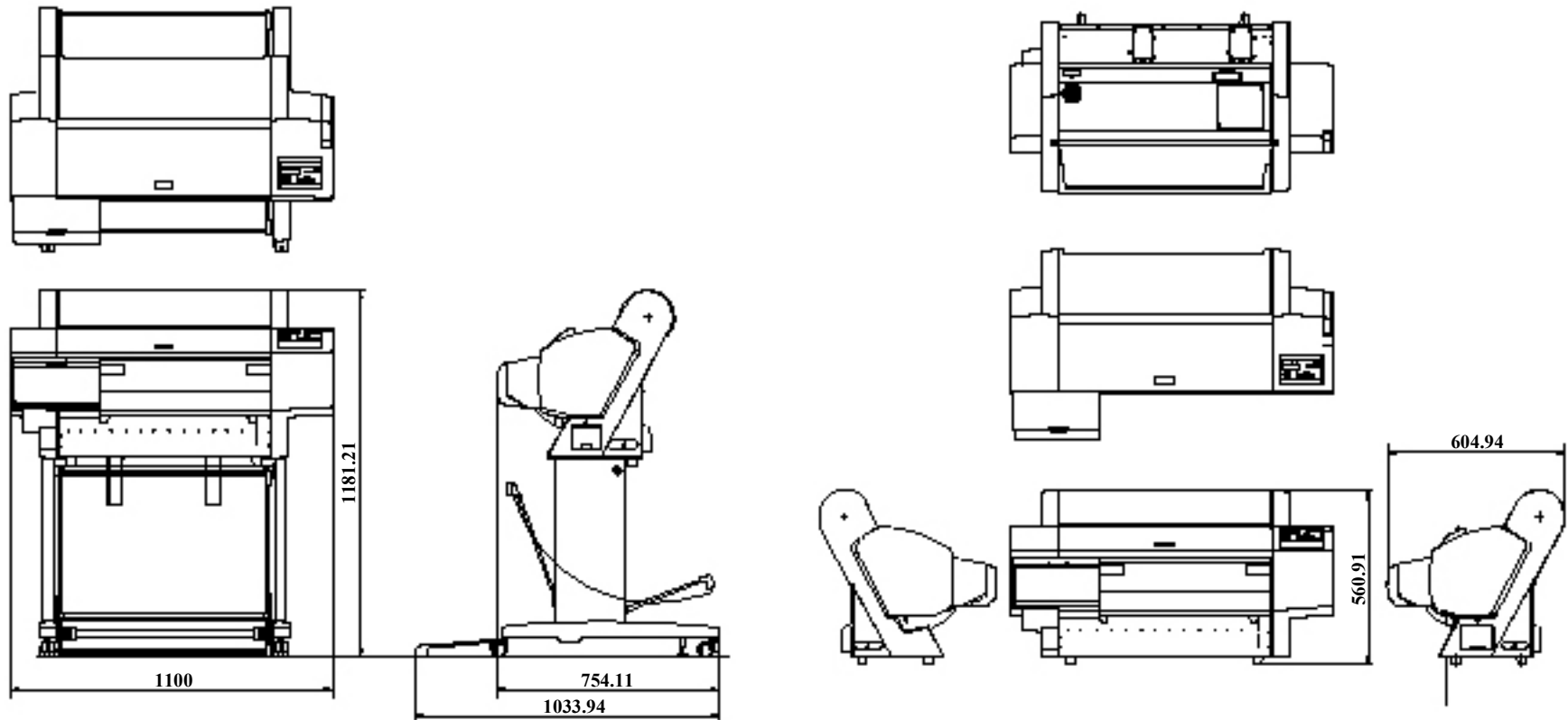

Figure 1-4. Overall Dimensions of Stylus Pro 7600

□ Dimensions of Unit

Model	Condition	Width (W) × Depth (D) × Height (H) (mm)
Stylus Pro 7600	Printer body	1100 × 805 × 561
	Rearward paper eject	1100 × 754 × 1181
	Frontward paper eject	1100 × 1034 × 1181
Stylus Pro 9600	Frontward paper eject	1624 × 691 × 1178
	Rearward paper eject	1624 × 697 × 1178
	Frontward paper eject	1624 × 1076 × 1178

- Note 1: For “rearward paper eject”, the paper exit tray is brought down toward the rear.
 Note 2: For “frontward paper eject”, the paper exit tray is brought down toward the front.

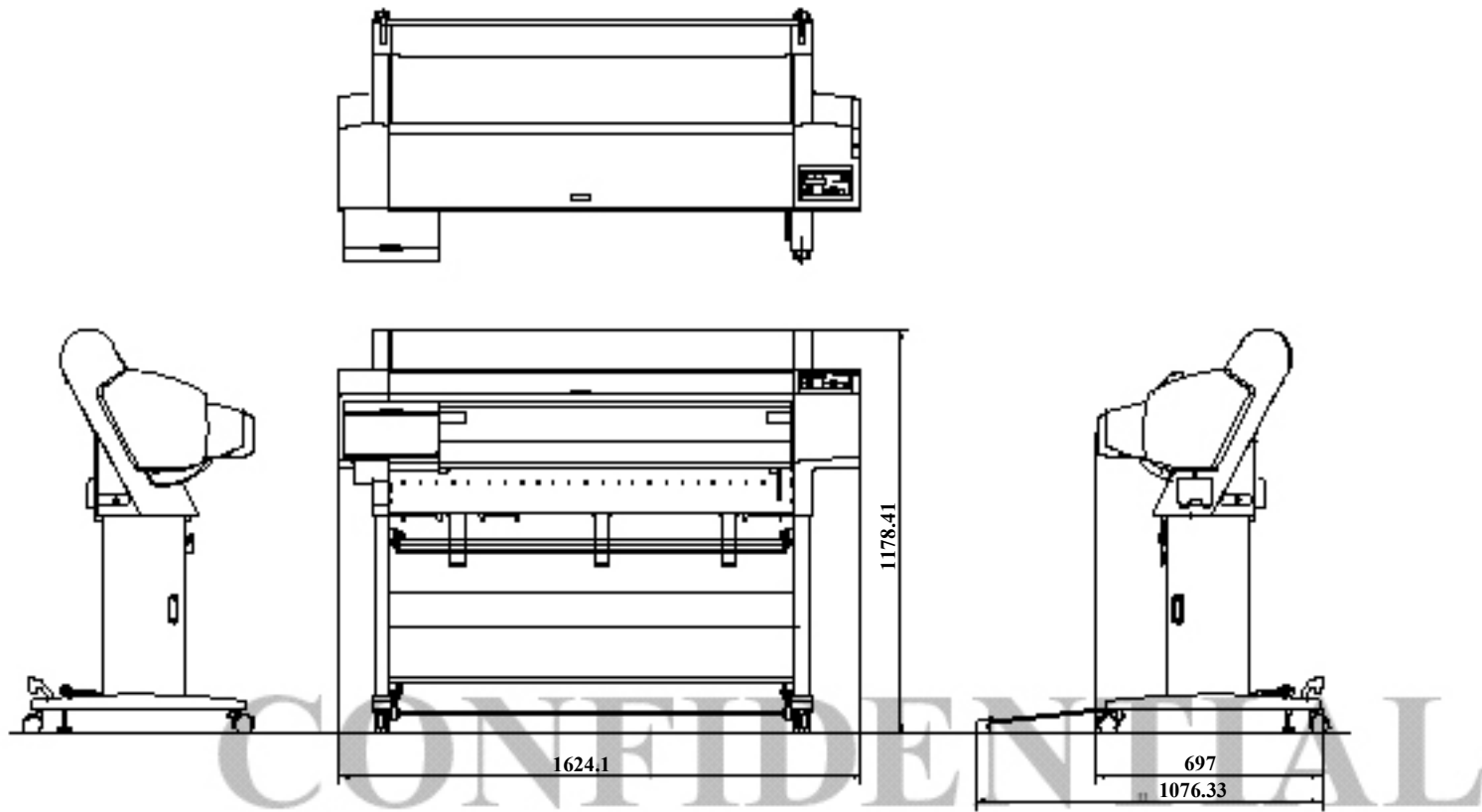

Figure 1-5. Overall Dimensions of Stylus Pro 9600

□ Weight

Model	Condition	Weight
Stylus Pro 7600	Printer body (without feet mounted) *	About 43.5 kg
	Feet	About 10.5 kg
Stylus Pro 9600	Printer body (without feet mounted) *	About 62.0 kg
	Feet	About 22.5 kg

Note "*": Excluding the ink cartridges

1.2.11 Accessories

This section describes the accessories and options for Stylus Pro 7600 and Stylus Pro 9600.

1.2.11.1 Accessories and Options for Stylus Pro 7600

- Standard Accessories
 - AC Cable
 - Change Plug Adapter 3pin to 2pin
 - 24 (2/3) inch roll paper spindle
 - Roll paper sample
 - Roll paper belt
 - Ink cartridges (110ml PK, MK, LK, C, M, LC, LM, Y)
 - Maintenance Tank
 - User's Manual
 - Driver & User's Manual
 - EPSON GrayBalancer & EPSON Printer Service Utility
 - Utility Software
 - Guarantee Card
 - Card holder
 - Carton Box
- Special Options
 - Special stand (PX70MCU)
 - Manual cutter unit 24" (PX70MCU)
 - Normal tension spindle 24" <2"/3"> (PX70RPSD)
 - Black ink replacement kit (Draining cartridge, Cleaning cartridge)

- Special Consumables
 - Ink cartridge (110ml)

Name	Model Number
	110 ml (Standard Product)
Photo Black	ICBK24
Matte Black	ICMB24
Light Black	ICGY24
Cyan	ICC24
Magenta	ICLC24
Light Cyan	ICM24
Light Magenta	ICLM24
Yellow	ICY24

Note : The 220 ml ink cartridges are supported only by Stylus Pro 9600.

- Special paper (Refer to “[1.2.5 Paper Specifications \(p.15\)](#)” for paper type and size)
- Maintenance tank
- Options Common to Other Printers
 - Auto cutter blade (PM90SPB)
 - Leo 2.13 (PRIFNW3S)
 - Fairbanks (PRIF14)

1.2.11.2 Accessories and Options for Stylus Pro 9600

- Standard accessories
 - AC Cable
 - Change Plug Adapter 3pin to 2pin
 - Special stand
 - 44 (2/3) inch roll paper spindle
 - Roll paper sample
 - Roll paper belt
 - Ink cartridges (110ml PK, MK, LK, C, M, LC, LM, Y)
 - Maintenance Tank
 - User's Manual
 - Driver & User's Manual
 - EPSON GrayBalancer & EPSON Printer Service Utility
 - Utility Software
 - Guarantee Card
 - Card holder
 - Carton Box
- Special Options
 - Manual cutter unit 44”(PX90MCU)
 - Normal tension spindle 44”<2”/3”> (PX90RPSD)
 - High tension spindle 44”<2”/3”> (PX90HSD)
 - Black ink replacement kit (Draining cartridge, Cleaning cartridge)

- Special Consumables
 - Ink cartridge (110 ml/220 ml (only for pigment))

Name	Model Number	
	110 ml (Standard Product)	220ml (Option)*
Photo Black	ICBK24	ICBK25
Matte Black	ICMB24	ICMB25
Light Black	ICGY24	ICGY25
Cyan	ICC24	ICC25
Magenta	ICLC24	ICLC25
Light Cyan	ICM24	ICM25
Light Magenta	ICLM24	ICLM25
Yellow	ICY24	ICY25

Note : The 220 ml ink cartridges are supported only by Stylus Pro 9600.

- Special paper (Refer to “[1.2.5 Paper Specifications \(p.15\)](#)” for paper type and size)
- Maintenance tank
- Options common to other printers
 - Auto cutter blade (PM90SPB)
 - Take-up roller (PMARFU1)
 - Leo 2.13 (PRIFNW3S)
 - Fairbanks (PRIF14)

1.3 External View and Parts Names

EXTERNAL VIEW

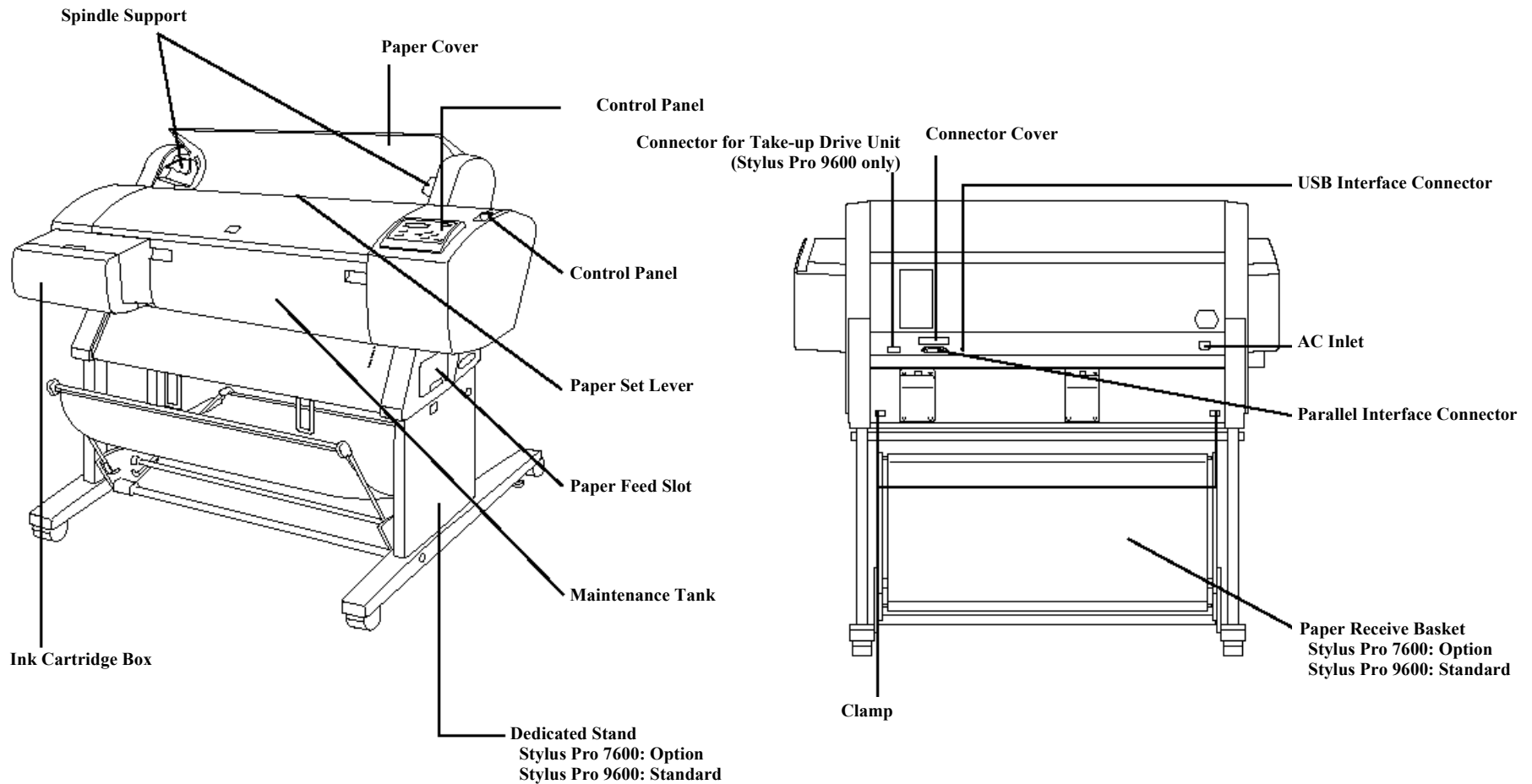

Note : Shown above is Stylus Pro 7600

Figure 1-6. External View and Parts Names

1.4 Operating Panel

1.4.1 Buttons and Functions

The operating panel contains the following buttons.

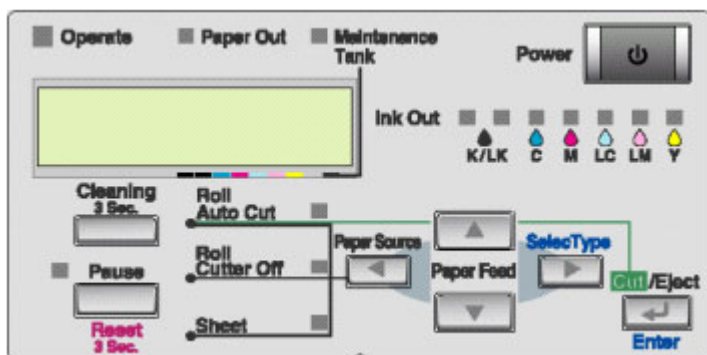

Figure 1-7. Panel Design

- Power
- Pause
- SelecType (Panel setting menu shift, setting item shift (down))
- Paper Feed Δ (setup value +)
- Paper Feed ∇ (setup value -)
- Paper Source (Item shift (up))
- Cut / Eject (Enter)
- Cleaning

1.4.1.1 Functions of Buttons

Table 1-20. Panel Functions

Switch	Function (Independent)	Function (in SelecType mode)	Function (+PowerOn)
Power	Power ON/OFF	-	-
Pause	Pause / ready, reset (press for 3 seconds)	Leaving SelecType mode	Maintenance mode
SelecType	<input type="checkbox"/> During printing Printer status menu shift <input type="checkbox"/> Except above Panel setting mode shift Cutter replace menu (press for 5 seconds)	Selection of SelecType menu (major categories)	-
Cut / Eject	<input type="checkbox"/> Eject sheet *1 <input type="checkbox"/> Feed roll paper from cutter mark to cutting position and cut. (Auto Cut)*1 <input type="checkbox"/> Feed roll paper to the manual cutting position (cutter OFF).*1	Confirm and save setting values	-
Paper Feed Δ	Paper feed (reverse)*2	(setup value +) Increase setup value	-
Paper Feed ∇	Paper feed (forward)*3	(setup value -) Decrease setup value	-
Paper Source	Select paper source	Selection of SelecType items (minor categories)	-
Cleaning	Cleans all heads (press for 3 seconds)	-	-
Paper Source+ Eject+paper feed	-	-	Maintenance mode 2
Eject + Paper feedD + Paper feed	-	-	Self-diagnosis mode
Cleaning + Paper Source + Eject	-	-	F/W download

- Note *1: It interrupts ink drying and runs the specified operation.
- *2: 1.27cm/second (5.0 cps) paper feeding for 2 seconds after the button is pressed.
13.2cm/second (52. cps) paper feed if pressed for another 2 seconds. Maximum reverse feeding is 20 cm by one press of the button.
- *3: 1.27 cm/second (5.0 cps) paper feed for 2 seconds after the button is pressed.
13.2 cm/second (52. cps) paper feed if pressed for another 2 seconds.

1.4.1.2 LEDs

The printer is equipped with the following LEDs.

The LEDs indicate printer status as follows:

Table 1-21. LEDs

LED (color)	Display	Printer Status
Operate (Green)	On	Printer power ON.
	Blink	Printer processing data, or in power OFF sequence.
Paper Out (Red)	On	Paper out, end of roll, confusion of roll paper and sheet, paper set lever is released, or paper is thick for cleaning
	Blink	Paper jam error, paper cutting error, paper not straight, paper recognition error, or paper (sheet) eject failure
Pause (Green)	On	Pause.
	Blink	Cleaning print head, or ink drying.
Ink Out (K1) (Red)	On	Black ink1 end, or wrong black ink
	Blink	Black ink1 low.
Ink Out (K2) (Red)	On	Black ink2 end, or wrong black ink
	Blink	Black ink2 low.
Ink Out (C) (Red)	On	Cyan ink end, or wrong cyan ink
	Blink	Cyan ink low.
Ink Out (M) (Red)	On	Magenta ink end, or wrong magenta ink
	Blink	Magenta ink low.
Ink Out (LC) (Red)	On	Light cyan ink end, or light cyan ink
	Blink	Light cyan ink low.
Ink Out (LM) (Red)	On	Light magenta ink end, or wrong light magenta ink
	Blink	Magenta ink low.

Table 1-21. LEDs (continued)

LED (color)	Display	Printer Status
Ink Out (Y) (Red)	On	Yellow ink end, or wrong yellow ink
	Blink	Yellow ink low.
Maintenance tank (Red)	On	Maintenance tank full error, or No maintenance tank error
	Blink	Maintenance tank almost full
Roll, Auto cut (Green)	On	Roll, Auto cut is selected.
	Blink	Confusion of roll paper and sheet, roll paper is not set.
Roll, Cutter off (Green)	On	Roll, Cutter off is selected.
	Blink	Confusion of roll paper and sheet, roll paper is not set.
Sheet (Green)	On	Sheet is selected.
	Blink	Confusion of roll paper and sheet, sheet is not set.

1.4.2 Indications on the Panel

1.4.2.1 IED Indications in Normal Mode

Operate

Table 1-22.

Displayed functions	Indicator status
While processing data, during power OFF sequence	Blink
Fatal error	Blink
Reset, timer IC reset/NVRAM clear	On
With power ON and in status other than those above	On
F/W updating completed	On

Paper Out

Table 1-23.

Displayed functions	Indicator status
Out of paper, end of roll	On
Confusion of roll paper and sheet	On
Paper set lever is released	On
Paper is thick for cleaning	On
Paper jam	Blink
Paper cutting error	Blink
Paper not straight	Blink
Paper check error	Blink
Paper (sheet) eject failure	Blink
Fatal error	Blink
Reset, timer IC reset/NVRAM clear	On
Maintenance call	On for 100ms at intervals of 5 seconds
F/W updating completed	On

Pause

Table 1-24.

Displayed functions	Indicator status
Print ready	On

Table 1-24.

Displayed functions	Indicator status
In SelecType mode	Off
During pause	Off
During ink drying time	Blink
During ink sequence	Blink
Other errors	Off
Fatal error	Blink
Reset, timer IC reset/NVRAM clear	On
Ink end (warning)	Blink
F/W updating completed	On

Ink Out

Table 1-25.

Displayed functions	Indicator status
Out of corresponded ink	On
No cartridge for corresponded ink	
Wrong cartridge for corresponded ink	
Illegal cartridge for corresponded ink	
Corresponded ink level low	Blink
Fatal error	Blink
Reset, timer IC reset/NVRAM clear	On
F/W updating completed	On

Maintenance tank

Table 1-26.

Displayed functions	Indicator status
Maintenance tank full	On
No maintenance tank	
Maintenance tank almost full warning	Blink
Fatal error	Blink
Reset, timer IC reset / NVRAM clear	On
F/W updating completed	On

1.4.2.2 LCD Indications in Normal Mode

Table 1-27. Indications (in Normal Mode)

Functions	LCD panel display	Indicator	PG setting
Ready to print	READY	*2	*1
Processing data	PRINTING	*2	*1
In power OFF sequence	POWER OFF		
In ink sequence	WAIT		*1
Initial filling	INK CHARGING nnn%		
Pause	PAUSE	*2	
Reset	RESET		
Initializing	WAIT		
Waiting for paper initialize start trigger	PRESS PAUSE BUTTON		
Initializing paper	WAIT		
Out of paper	PAPER OUT		
Difference with roll paper and sheet	LOAD XXX PAPER		
Paper set lever is released	LOAD PAPER	*3	
Paper jam	PAPER JAM		
Cover open	COVER OPEN		
Paper set lever is released during operation	SECURE PAPER LEVER		
Paper cutting error	PAPER NOT CUT		
Paper not straight	PAPER NOT STRAIGHT		
Paper check error	RELOAD PAPER		
End of roll	PAPER OUT		
Problem with paper output (sheet)	RELOAD PAPER		
Ink out	INK OUT		
Ink low	INK LOW		*1
No ink cartridge	NO INK CARTRIDGE		
Defective ink cartridge	SET INK CARTRIDGE		
Wrong cartridge	WRONG CARTRIDGE		

Table 1-27. Indications (in Normal Mode) (continued)

Functions	LCD panel display	Indicator	PG setting
Command error	COMMAND ERROR		
Type B interface error	OPTION I/F ERROR		
Fatal error	SERVICE. REQ. nn		
Maintenance request	MAINTENANCE REQ. nn		*1
Timer IC reset/NVRAM clear	WAIT		
After replacing ink cartridge			
Ink cover open	CLOSE INK CART. COVER		
Wrong ink cartridge (dye/pigment)	WRONG CARTRIDGE		
Non-genuine cartridge	INVALID CARTRIDGE		
Maintenance tank almost full warning	MAINTENANCE TANK ALMOST FULL		
Maintenance tank full	MAINTENANCE TANK FULL		
No maintenance tank	NO MAINTENANCE TANK		
Unable to print error	UNABLE TO PRINT		
Paper is too thick for cleaning	REMOVE PAPER		
Ink is not enough for cleaning	NOT ENOUGH INK		
Ink cartridge replacing	SET INK CARTRIDGE		
Ink drying	INK DRY nn MIN		*5
Restart request	TURN PRINTER PWR OFF AND THEN ON		
Restarting request	TURN PWR OFF AND ON		

Note *1: When PG setting = WIDE or WIDER, “W” is displayed at the left of lower line.
When PG setting = NARROW, “N” is displayed at the left of lower line.

*2: Ink remaining / available rate of maintenance tank are displayed with indicator.

*3: Suction is displayed with indicator.

*4: Character strings on the second line resulting from line feed above are displayed on the second line of LCD panel.

*5: It is displayed only for page delay.

NOTE: For details of error display, refer to “3.2.1 Errors (p.123)”.

1.4.3 SelecType

1.4.3.1 Outline

□ Startup

The SelecType mode is selected by pressing the SelecType button during print ready, warning, or maintenance call status. The printer is then automatically incapable of printing.

□ Operation

1. The Printer setting menu can be entered by pushing the SelecType button during menu shift available state (Print ready, no paper). It is shifted to setting menu select mode, and the setting menu is displayed on the left side of the LCD upper line.
2. Each setting menu is displayed one after another by pressing Paper Feed $\Delta\nabla$ buttons in the setting menu select mode. It is shifted to setting item select menu by pressing the SelecType button. [Setting menu] is displayed on the upper line, and [Setting item] is displayed on the lower line.
3. The setting menu is displayed one after another by pressing Paper Feed $\Delta\nabla$ buttons in the setting item select mode. It is shifted to setting value select mode of the setting item by pressing the SelecType button. [Setting item] is displayed on the upper line, and [Setting value] is displayed on the lower line. The '*' represents the current setup value.
4. Setting value is displayed on the lower line one after another by pressing Paper Feed $\Delta\nabla$ buttons in the setting value select mode if the setting value can be changed. The '*' represents the current setup value.
5. When the Enter button is pressed in the setting value select mode, the displayed setting value is entered as the current setting value. If it has a corresponded operation, it is started. No operation occurs if '*' is already displayed.
6. It returns to the setting item select menu by pressing the Paper Source button in the setting value select mode. It returns to the setting menu select mode by pressing the Paper Source button in the setting item select menu.

□ Termination

- The printer enters the menu shift available status when the Pause button is pressed in the SelecType mode.
- The printer enters the menu shift available status when the Paper source button is pushed once in setting menu select mode.
- The printer enters the menu shift available status when setting initialization is executed.
- The printer enters the print ready status after the nozzle check pattern or the status sheet is printed.
- The printer enters the menu shift available status after black ink is replaced.
- The printer enters the menu shift available status after the cutter is replaced.
- The printer returns to the menu shift available status when Pause button is pressed in any modes.

NOTE: Under the special condition, it sometimes can not return to the status.

□ Panel display

Character strings on the second line in the following list are displayed on the second line of LCD panel. Setup values are displayed on the second line of LCD panel.

1.4.3.2 Panel Setting Menu Item

Table 1-28. Panel setting menu item

Top menu (Panel display)	Item menu	Panel display	Setup value (Underlined: Default)	See	
Printer setting menu (PRINTER SETTING MENU)	PG setting	PLATEN GAP	<u>AUTO</u> , NARROW, WIDE, WIDER	p.40	
	Page line	PAGELINE	<u>ON</u> OFF	p.41	
	Interface switching	INTERFACE	<u>AUTO</u> PARALLEL, USB, OPTION	p.41	
	Code page switching	CODEPAGE	<u>PC437</u> , PC850	p.41	
	Roll paper margin	ROLL MARG	<u>T/B 15MM</u> , 3MM, 15MM	p.41	
	Detect paper width	PAPERSIZECHK	<u>ON</u> OFF	p.42	
	Detect skew error	PAPERALIGNCHK	<u>ON</u> OFF	p.42	
	Job timeout setting	TIMEOUT	OFF, 30sec, 60sec, 180sec, 300sec	p.42	
	No margin print setting	NO MARGIN	L / R ONLY, 1 CUT, 2 CUTS	p.43	
	Cutter adjustment	CUTTER ADJ	EXEC	p.44	
	Auto margin refresh	REFRESH MRGN	ON, OFF	p.44	
	Initialize setting value	INITSETTING	EXEC.	p.45	
Test print menu (TESTPRINTMENU)	Nozzle check pattern print	NOZZLECHECK	PRINT	p.45	
	Status print	STATUSCHECK	PRINT	p.46	
	Job information print	JOBINFO	PRINT	p.48	
Printer status menu (PRINTERSTATUS MENU)	Firmware version	VERSION	BXxxxx (D or P)	p.49	
	Printable pages of ink cartridge	Black1	PRINTABLEPG	K1 xxxxxxxxPG*	p.49
		Black2		K2 xxxxxxxxPG*	
		Cyan		C xxxxxxxxPG*	
		Magenta		M xxxxxxxxPG*	
		Light Cyan		LC xxxxxxxxPG*	
		Light Magenta		LM xxxxxxxxPG*	
		Yellow		Y xxxxxxxxPG*	

Table 1-28. Panel setting menu item (continued)

Top menu (Panel display)	Item menu		Panel display	Setup value (Underlined: Default)	See
Printer status menu (PRINTERSTATUS MENU)	Ink remaining	Black1	INKLEFT	K1 XXXXX (XXXXX is one of followings) (0%,nn%,E* F,E** F,E*** F,E**** F,E*****F)	p.49
		Black2		K2 XXXXX (XXXXX is one of followings) (0%,nn%,E* F,E** F,E*** F,E**** F,E*****F)	
		Cyan		C XXXXX (XXXXX is one of followings) (0%,nn%,E* F,E** F,E*** F,E**** F,E*****F)	
		Magenta		M XXXXX (XXXXX is one of followings) (0%,nn%,E* F,E** F,E*** F,E**** F,E*****F)	
		Light Cyan		LC XXXXX (XXXXX is one of followings) (0%,nn%,E* F,E** F,E*** F,E**** F,E*****F)	
		Light Magenta		LM XXXXX (XXXXX is one of followings) (0%,nn%,E* F,E** F,E*** F,E**** F,E*****F)	
		Yellow		Y XXXXX (XXXXX is one of followings) (0%,nn%,E* F,E** F,E*** F,E**** F,E*****F)	
Printer status menu (PRINTERSTATUS MENU)	Maintenance tank count		MAINT TANK	E F,E* F,E** F,E*** F,E**** F,E*****F	p.49
	Use counter	Ink counter	USECOUNT	INK xxxxx.x ml	p.50
		Paper counter		PPR xxxxx.x cm	
	Use counter clear	Ink counter clear	USECOUNTCLR	INK EXEC	p.50
		Paper counter clear		PAPER EXEC	
	Job history (10 jobs)		JOBHISTORY	No.0-No.9	p.50
	Job history clear		JOB HSTRY CLR	EXEC	p.50
	Total print pages		TOTAL PRINTS	nnnnnnPG (Max. 6 figures)	p.50
	Use life	Cutter life	SERVICELIFE	CUTTER XXXXXXXX (XXXXX is one of followings) (0%,nn%,E* F,E** F,E*** F,E**** F,E*****F)	p.51
				CR MOTOR XXXXXXXX (XXXXX is one of followings) (0%,nn%,E* F,E** F,E*** F,E**** F,E*****F)	p.51
				PF MOTOR XXXXXXXX (XXXXX is one of followings) (0%,nn%,E* F,E** F,E*** F,E**** F,E*****F)	p.52
HEAD UNIT XXXXXXXX (XXXXX is one of followings) (0%,nn%,E* F,E** F,E*** F,E**** F,E*****F)				p.52	
Cleaning unit life monitor				CL UNIT XXXXXXXX (XXXXX is one of followings) (0%,nn%,E* F,E** F,E*** F,E**** F,E*****F)	p.53

Table 1-28. Panel setting menu item (continued)

Top menu (Panel display)	Item menu	Panel display	Setup value (Underlined: Default)	See	
User Paper Setup Menu (PAPERCONFIG. MENU)	Paper select	PAPERNUMBER	<u>STD</u> , 1~10	p.56	
	Print paper thickness detection pattern	THICKNESS PAT	PRINT*4		
	Select paper thickness number	THICKNESS NUM	1~17 *5		
	Cutting pressure	CUTPRESSURE	0%~100%		
	Cutting method	CUTMETHOD	<u>3STEPS</u> , 4STEPS		
	Paper feed adjustment	PPRFEEDADJ	-1.00%~1.00%		
	Ink drying time	DRYINGTIME	<u>0.0sec</u> ~5.0sec		
	Vacuum	SUCTION	<u>NORM</u> , LOW		
	Print adjustment (MW)	PRINTADJ	0 ~ <u>5</u> ~ 9		
Maintenance menu (MAINTENANCE)	Powerful cleaning	PWRCLEANING	EXEC	p.60	
	Black ink replacement (only for pigment printer)	Replace BK ink	BLKINKCHNG	EXEC	p.64
		Release ink lever	RELEASE INKLEVER	-	
		Remove all ink cartridges	REMOVE ALL INKCARTRIDGES	-	
		Select ink set after change	SELECTINKSET	* Select 2 types from following depending on the situation #1 PHOTO:#2 LGT #1 MAT:#2 MAT #1 MAT:#2 LGT #1 PHOTO:#2LGT (2 cartridges change) #1 MAT:#2 LGT #1 MAT:#2 MAT (2 cartridges change)	
		Set draining cartridge	INSERTDRAINING CARTRIDGEIN#X	-	
		Ink draining	DRAINING	xxx%	
		Set cleaning cartridge	INSERTCLEANING CARTRIDGEIN#X	-	
		Cleaning	CLEANING	xxx%	
		Cleaning solution draining	DRAINING	xxx%	
		Set draining cartridge	INSERTDRAINING CARTRIDGEIN#X	-	
		* Repeat operation after “SELECT INK SET” for 2 cartridges change.			
		Ink charging	INKCHARGING	xxx%	
		Set all ink cartridges	INSERTALLINK CARTRIDGES	-	
	CSIC information	* See “BK ink cartridge replacement (p64)” for details			
	Cutter Replacement	Replace cutter	CUT.REPLACE	EXEC.	p.60
		Cover open guide	OPENLOWERCOVER	-	
		Cutter replacement guide	REPLACECUTTER	-	
		Cover close guide	CLOSE LOWER COVER	-	

Table 1-28. Panel setting menu item (continued)

Top menu (Panel display)	Item menu	Panel display	Setup value (Underlined: Default)	See	
Gap adjustment menu (HEADALIGNMENT MENU)	Paper thickness (in 0.1mm units)	PAPERTHKNS	<u>STD</u> , 0.0MMÅ 1.6MM	p.60	
	Adjustment pattern select and print	ALIGNMENT	BI-D BLACK, BI-D ALL, UNI-D ALL		
	Bi-D adjustment Black	240CPS	#1 K1		1~ <u>5</u> ~9
		240CPS	#2 K1		1~ <u>5</u> ~9
		190CPS	#3 K1		1~ <u>5</u> ~9
	Bi-D adjustment All color	240CPS VSD1 Total 7 colors	#1 K1 ~ #1 Y		1~ <u>5</u> ~9
		240CPS VSD2 Total 7 colors	#2 K1 ~ #2 Y		1~ <u>5</u> ~9
		190CPS VSD4 Total 7 colors	#3 K1 ~ #3 Y		1~ <u>5</u> ~9
	Head gap adjustment (Uni-D)	240CPS VSD1 Total 6 colors (K1 is standard)	#1 K2		1~ <u>5</u> ~9
			:		:
			#1 Y		1~ <u>5</u> ~9
		240CPS VSD2 Total 6 colors (K1 is standard)	#2 K2		1~ <u>5</u> ~9
			:		:
			#2 Y		1~ <u>5</u> ~9
	190CPS VSD4 Total 6 colors (K1 is standard)	#3 K2	1~ <u>5</u> ~9		
:		:			
#3 Y		1~ <u>5</u> ~9			

1.4.3.3 PG Setting

Selecting this mode allows the user to set the platen gap. The relationship between panel setting, command setting (SN command), and actual platen gap position is shown below.

Table 1-29. PG Setting Values

Paper thickness sensor	PH command	Panel	SN command	Actual PG position	Note		
Less than 0.3mm	00H	Narrow	-	Minimum	*1		
		Standard		Minimum	*1		
		Wide		Small			
		Wider		Middle			
	01H-06H	Narrow		Minimum	Minimum		
				Small	Minimum		
				Middle	Small		
				Big	Middle		
		Standard		Minimum	Minimum		
				Small	Small		
				Middle	Middle		
				Big	Big		
		Wide		Minimum	Small		
				Small	Middle		
				Middle	Big		
				Big	Big		
		Wider		Minimum	Middle		
				Small	Big		
				Middle	Big		
				Big	Big		
		07H-12H	-	-	-	Big	

Table 1-29. PG Setting Values (continued)

Paper thickness sensor	PH command	Panel	SN command	Actual PG position	Note	
More than 0.3mm Less than 0.7mm	00H-06H	Narrow	Minimum	Small		
			Small	Small		
			Middle	Small		
			Big	Middle		
		Standard		Minimum	Small	
				Small	Small	
				Middle	Middle	
				Big	Big	
		Wide		Minimum	Small	
				Small	Middle	
				Middle	Big	
				Big	Big	
		Wider		Minimum	Middle	
				Small	Big	
				Middle	Big	
				Big	Big	
07H-12H	-	-	-	Big		
More than 0.7mm	-	-	-	Big		

- Note 1: Only in this case, SN command is ignored. When paper thickness is 0.15mm, it is operated with minimum Bi-D value and minimum SN(PG).
- 2: When “Wide” or “Wider” is set, “W” is displayed on the left side of LCD lower line.
- 3: When “Narrow” is set, “N” is displayed on the left side of LCD lower line.

The actual platen gap may be set to any of the following

Table 1-30.

Position	Gap width	Application
Wide	2.6 mm	Thick paper
Medium	2.2 mm	Reduce the smearing on the printed image of thin paper.
Narrow	1.2 mm	Thin paper (Default)
Minimum	0.7 mm	Thin film (Film, glossy media)

1.4.3.4 Page Lines

Selecting this mode allows the user to set the page line print mode. Setup is the same as horizontal lines ON command (AC 02H 00H 00H 02H) in the automatic cutting setup. The solid line type is used.

1.4.3.5 Interface Select

Selecting this mode allows selection of the parallel, USB, or optional interface, or automatic interface selection.

1.4.3.6 Code Page Switching

Selecting this mode allows switching between PC437 and PC850 for the code page.

1.4.3.7 Roll Paper Margin

Setting this panel allows switching roll paper margin, all sides 3 mm / all sides 15 mm / top and bottom 15 mm, right and left 3 mm. This setting is only valid for roll paper. It's not valid for sheets. This setting change only margin, and doesn't change image size.

- If margin = 3 mm is set
Printing positions of vertical line and horizontal line are same as the theoretical paper size.
- If margin = 15 mm, or Top/Bottom 15 mm is set
Printing positions of vertical line and horizontal line are widened by 12 mm for all sides or only top and bottom. (See Figure 1-8)

If printable area is more than X = 15 mm from the right edge of paper, the portion is clipped.

Vertical line is not printed. (See Figure 1-9)

NOTE 1: The top margin is also set with "Set the top margin" (SN command).
Actual top margin is decided as follows:

- Panel setup value (top margin) > Paper top margin
(Panel setup value is used as the top margin)
- Panel setup value (top margin) < Paper top margin
(Paper top margin is used as the top margin)

2: Under special conditions, the right / left margin can be set to 0.

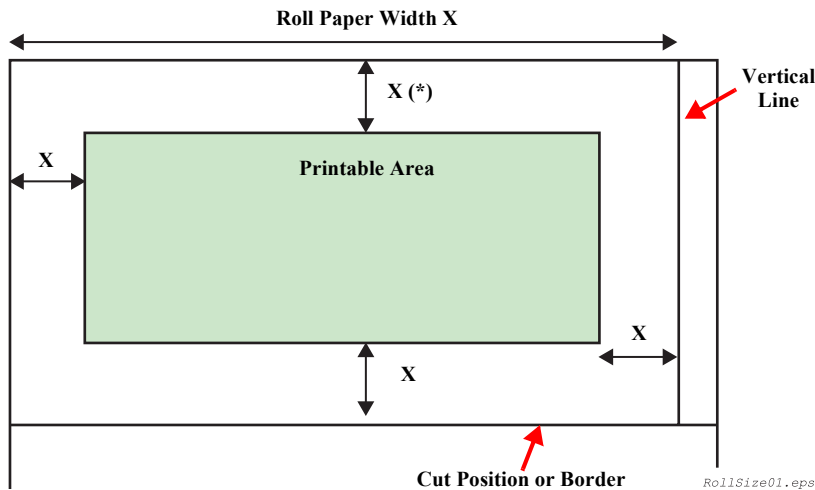

Figure 1-8. Roll Paper Margin (1)

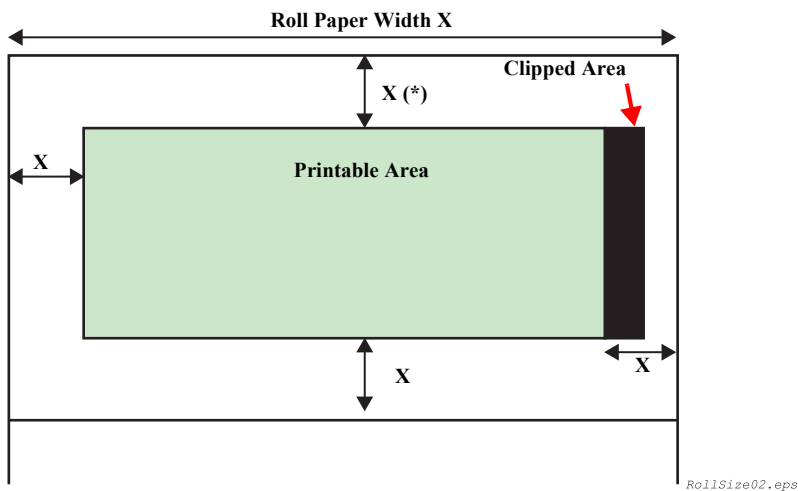

Figure 1-9. Roll Paper Margin (2)

1.4.3.8 Detect Paper Width

When the paper width detection function is OFF, the printer can print on the platen if the image to be printed is bigger than the set paper (larger than borderless print area). Therefore the user must bear responsibility in selecting this function OFF setting. At paper initial feeding or print starting, the paper is fed by the distance between grid roller and #1 nozzle unconditionally. The print starts from that position. (No back-feed in the other sequences) Even when paper has too low reflection to be detected, the paper is fed so as not to print on the platen.

The same specifications are applied to sheets and auto loading.

The above-mentioned paper width detection OFF sequence is just for the first page in the case of roll paper.

The paper auto cutting function does not check whether paper is cut successfully or not.

1.4.3.9 Detect Skew Error

With PAPER NOT STRAIGHT = OFF setting, the "PAPER NOT STRAIGHT" error will not be displayed and printing will be continued.

With this setting, even if the printing image is out of paper because the paper is not straight, the printer will not inform the user of such an error. Therefore, the user must bear responsibility in selecting this function OFF setting.

1.4.3.10 Job Timeout Setting

When print data is interrupted longer than setting time although data receiving is available, the print job is regarded as the end, and the printer runs paper feeding operation.

1.4.3.11 No margin print setting

No margin print mode can be switched with these settings.

Following 3 modes can be selected;

Table 1-31.

Mode	Operation
Left/right no margin (default)	Only right/left margin can be set to 0. Top/bottom margin is set with roll paper margin setting.
4 sides no margin / 1 cut	Left/right and top/bottom margin can be set to 0. Cutting methods are following; <ul style="list-style-type: none"> • After JOB is started, it cuts off the paper edge with the minimum margin during printing. • There is no margin between pages during JOB. It cuts off paper on the border of image. • After JOB is completed, it cuts off paper at the end of image.
4 sides no margin / 2 cuts	Left/right and top/bottom margin can be set to 0. Cutting methods are following; <ul style="list-style-type: none"> • After JOB is started, it cuts off the paper edge with the minimum margin during printing. • It cuts off paper at the end of image each page. • It cuts off paper after paper feeding with the minimum margin (*3).



*1. When 4 sides no margin / 2 cuts is selected, vertical length will be 2mm shorter than actual print size after cutting.

*2. When roll paper cutter OFF and page line print ON, page line is printed for each cutting position including page top cutting.

*3. We recommend 6cm for glossy paper, and 10cm for other papers.

No margin setting

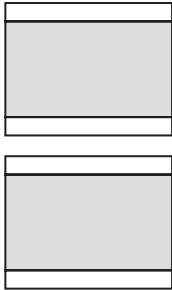
Table 1-32.

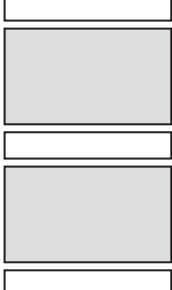
No margin mode	Right/left no margin No margin mode	4 sides no margin (1 cut)	4 sides no margin (2 cuts)
Printer operation			
Driver setting	No margin print	No margin print Auto cut	No margin print Auto cut
Panel setting (Printer setting menu)	NO MARGIN L/R ONLY	NO MARGIN 1 CUT	NO MARGIN 2 CUTS
Notes	Default	<ul style="list-style-type: none"> • Uneven coloring may occur for some image, because top edge is cut with print interruption. • Continuous data may be left slightly on the top/bottom because of cutter position gap. 	<ul style="list-style-type: none"> • Uneven coloring may occur for some image, because top edge is cut with print interruption. • The top/bottom is cut inside of border to prevent margin from leaving on paper. Vertical length will be 2mm shorter than actual print size after cutting.

1.4.3.12 Cutter position adjustment

Cutter position can be adjusted with this mode. Cutter position adjustment pattern is printed, and the cutter is adjusted with cutter position number entered by users.

NOTE: This adjustment is effective for top/bottom no margin print.

□ Setting procedure

1. Set paper.
2. Enter Cutter position adjustment menu with the panel.
3. Print cutter position adjustment pattern.
4. Select the best pattern number and enter the number.

NOTE 1: When “1 cut” is selected with panel, it is not operated.
2: Setting value can be selected from 1 to 17 with “Paper Feed” button.

□ Level structure of Cutter position adjustment menu

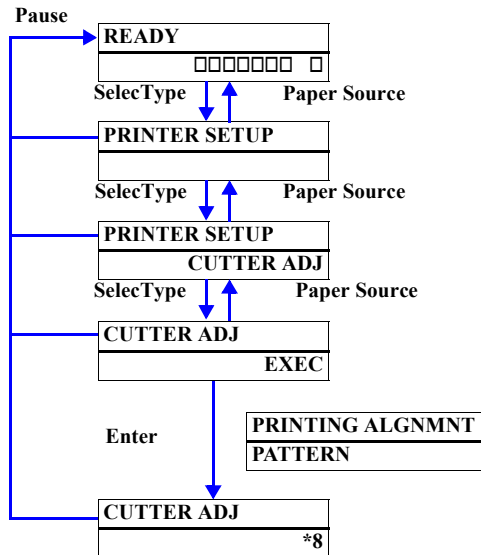

□ Cutter position adjustment pattern

- Output paper size : A4
- Font : Built-in font
- Print sample : See following picture.

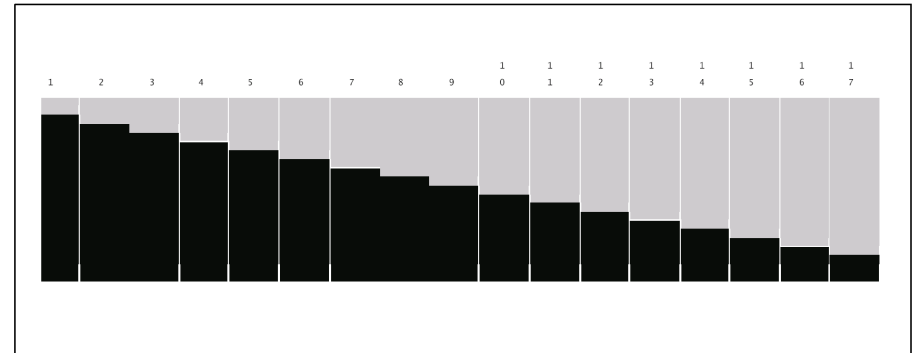

Figure 1-10. Cutter position adjustment pattern

■ Number in print pattern and cutter position

Number in print pattern	1	2	3	...
Adjustment value				...

...	15	16	17
...			

1.4.3.13 Auto margin refresh

When this setting is ON, paper edge is automatically cut to prevent print dirt after 4 sides no margin print. The cutting length is depends on the minimum cut length at this time.

1.4.3.14 Panel Setup Value Initialization

Selecting this mode allows the user to return all the values set on the panel to the default values.

Initializing items are following;

Table 1-33.

Setting item	After initialization
PG setting	STANDARD
Page line	ON
I/F switching	AUTO
Code page switching	PC437
Roll paper margin setting	T/B 15mm
Paper width detection	ON
Paper skew detection	ON
Job timeout setting	30 sec
No margin print	1 cut
Cutter position adjustment	(Manufacture setting)
Ink end warning message	ON

1.4.3.15 Nozzle Check Pattern Printing

Selecting this mode allows the user to print the firmware version, the waste ink counter, and the nozzle check pattern.

- Order of colors from left
Black1, Cyan, Magenta, LightCyan, LightMagenta, Yellow - Black2
- Each parameter indicates the following:
 - <Z>: N for Stylus Pro 7600, W for Stylus Pro9600
 - <xxxx>: firmware version
 - <I>: D for dye, P for pigment
 - <yyy>: Maintenance tank available quantity
 - <aaaaaaa>: total ink counter just before print the last nozzle check pattern (7 figures)
 - <bbbbbbb>: total ink counter just before print the nozzle check pattern (7 figures)
 - <cccccc>: value of <aaaaaaa>-<bbbbbbb> (7 figures)
 - <dddd.d>: total paper counter just before print the last nozzle check pattern (5.1 figures)
 - <eeee.e>: total paper counter just before print the nozzle check pattern (5.1 figures)
 - <ffff.f>: value of <dddd.d>-<eeee.e> (5.1 figures)

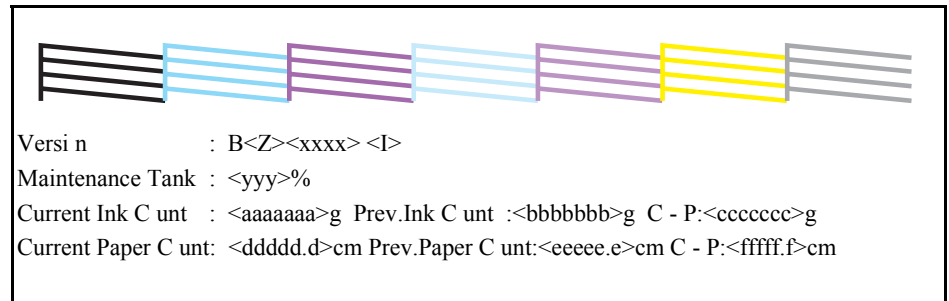

Figure 1-11. Nozzle Check Pattern Printing

1.4.3.16 Status Printing

Selecting this mode allows the user to print the current panel settings.

Print status sheet with the following specifications.

- Print paper size:A4
- Font: Built-in font
- Output procedure:
 1. Press the [SelcType] button on the control panel to enter the panel setting menu.
 2. Press the [Paper Feed Δ] or [Paper Feed ∇] to display “TEST PRINT MENU”.
 3. Press the [SelcType] button to enter the item menu select status and then press the [Paper Feed Δ] or [Paper Feed ∇] again to display [STATUS CHECK].
 4. Select the item by pressing the [SelcType] button again.
 5. Press the [Enter] button to execute status sheet printing.
- Explanation of contents:

#1: XX-XX-XX-XX-XX-XX-XX	Color Adjust ID information (ID1) *4	
#2: XX-XX-XX-XX-XX-XX-XX	Color Adjust ID information (ID2M)	
Type-B	Whether optional Type-B I/F is mounted or not	
Current Setting	Setting contents of “PRINTER SETTING MENU” in SelcType mode	
Printer Status	Version	Installed firmware version
	Total Print	Total number of printed sheets
	Use Ink	Ink consumption counter value (total cumulative consumption by printing, flushing and cleaning)
	Use Paper	Paper consumption counter value (total cumulative paper feed amount by printing)
	Mainte Tank	Remaining ink volume in Maintenance Tank *1
	Cutter Life	Remainder of cutter life *2
	CR Motor	Remainder of CR motor life *2
	PF Motor	Remainder of PF motor life *2
	Head	Remainder of Print Head life *2
	Cleaner	Remainder of Cleaning Unit life *2

Ink Cartridge *3	Manufature	Display of manufacturer
	Ink Type	Display of ink kind
	Ink Color	Display of ink color
	Ink Capacity	Display of capacity to contain ink
	Ink Left	Display of volume of remaining ink *1
	Production Date	Year and month of manufacture
	Expire Date	Expiration of guaranteed period for use
	Ink Life	Guaranteed period for use after unpacking
	Passed	Time having elapsed after unpacking
	Printable Sheet	Number of sheets which can be printed with the remaining ink (calculated value)

Note *1: Details of display of remaining ink volume in Maintenance Tank

100 ~ 81%	E*****F
80 ~ 61%	E**** F
60 ~ 41%	E*** F
40 ~ 21%	E** F
20% ~ 10%	E* F
Less than 10%	nn%
0% (End)	0%

*2: Details of display of remainder of cutter life, CR motor life, PF motor life, Print Head life or Cleaning Unit life

100 ~ 81%	E*****F
80 ~ 61%	E**** F
60 ~ 41%	E*** F
40 ~ 21%	E** F
20% ~ 1%	E* F
Less than 1%	F F

*3: The ink cartridge information is displayed based on the information inside the CSIC on the ink cartridge.

*4: This Color Adjust ID information (ID1) is the same as can be checked through the printer driver.

```

#1 XX-XX-XX-XX-XX-XX
#2 XX-XX-XX-XX-XX-XX
Type B          :Uninstalled
- Current Setting +-----+ Printer Status +-----+
Platen Gap      :Standard      | Version          :BWxxxx P
Page Line       :On            | Total Prints     :xxxxxx PG
Interface       :Parallel     | Use Ink          :xxxxxx.x ml
Code Page       :PC437        | Use Paper        :xxxxxx.x cm
Margine         :T/B15mm      | Mainte. Tank    :E[*****]F
No Margine      :1 Cut         | Cutter Life     :E[*****]F
Refresh         :On           | CR Motor        :E[*****]F
Paper Size Check :ON           | PF Motor        :E[*****]F
Paper Align Check :ON           | Head            :E[*****]F
Time Out        :30sec        | Cleaner         :E[*****]F
- Ink Cartridge +-----+
Manufacturer    : EPSON GENUINE INK EPSON GENUINE INK EPSON GENUINE INK
Ink Type       :      Pigment          Pigment          Pigment
Ink Color      :      Photo Black      LightBlack      Cyan
Ink Capacity   :      110ml            110ml            110ml
Ink Left       :      E[*****]F      E[*****]F      E[*****]F
Production Date :      `02/03            `02/03            `02/03
Expire Date    :      `03/10            `03/10            `03/10
Ink Life       :      06 months         06 months         06 months
Passed        :      02 months         02 months         02 months
Printable Sheet :      120 pages         120 pages         120 pages
-----+-----+-----+-----+
EPSON GENUINE INK  EPSON GENUINE INK EPSON GENUINE INK EPSON GENUINE INK
Pigment           Pigment           Pigment           Pigment
Magenta           LightCyan          LightMagenta      Yellow
110ml             110ml             110ml             110ml
E[*****]F       E[*****]F       E[*****]F       E[*****]F
`02/03            `02/03            `02/03            `02/03
`03/10            `03/10            `03/10            `03/10
06 months         06 months         06 months         06 months
02 months         02 months         02 months         02 months
120 pages         120 pages         120 pages         120 pages
-----+-----+-----+-----+

```

Figure 1-12. Status Sheet Print Pattern

1.4.3.17 Job Information Print

With this mode, users can print job information saved in the printer. (Max. 10Job)

Definition of job is followings;

- Adjustment patterns and test patterns
(Gap adjustment, Nozzle check pattern, Status print, Cutter position, Paper thickness detection)
- Print data from host
- Job information print

The printer prints job information print pattern in the following specifications;

- Print paper size:A4
- Font: Built-in font
- Print sample: See the chart at right.

NOTE: For details of Job Information, see “1.4.3.30 Job information (p55)”.

```

No.0
Doc Name :
User Name :                               I/F Type : Unknown           Job State : Complete
UsedInk : 123.456 ml   Used Paper : 12345 mm (w) x 12345 mm (h)
Print Start Time : 00/00/0000 : 00           Used Time : 12345678 min

No.1
Doc Name :
User Name :                               I/F Type : Unknown           Job State : Complete
UsedInk : 123.456 ml   Used Paper : 12345 mm (w) x 12345 mm (h)
Print Start Time : 00/00/0000 : 00           Used Time : 12345678 min

No.2
Doc Name :
User Name :                               I/F Type : Unknown           Job State : Complete
UsedInk : 123.456 ml   Used Paper : 12345 mm (w) x 12345 mm (h)
Print Start Time : 00/00/0000 : 00           Used Time : 12345678 min

No.3
Doc Name :
User Name :                               I/F Type : Unknown           Job State : Complete
UsedInk : 123.456 ml   Used Paper : 12345 mm (w) x 12345 mm (h)
Print Start Time : 00/00/0000 : 00           Used Time : 12345678 min

No.4
Doc Name :
User Name :                               I/F Type : Unknown           Job State : Complete
UsedInk : 123.456 ml   Used Paper : 12345 mm (w) x 12345 mm (h)
Print Start Time : 00/00/0000 : 00           Used Time : 12345678 min

No.5
Doc Name :
User Name :                               I/F Type : Unknown           Job State : Complete
UsedInk : 123.456 ml   Used Paper : 12345 mm (w) x 12345 mm (h)
Print Start Time : 00/00/0000 : 00           Used Time : 12345678 min

No.6
Doc Name :
User Name :                               I/F Type : Unknown           Job State : Complete
UsedInk : 123.456 ml   Used Paper : 12345 mm (w) x 12345 mm (h)
Print Start Time : 00/00/0000 : 00           Used Time : 12345678 min

No.7
Doc Name :
User Name :                               I/F Type : Unknown           Job State : Complete
UsedInk : 123.456 ml   Used Paper : 12345 mm (w) x 12345 mm (h)
Print Start Time : 00/00/0000 : 00           Used Time : 12345678 min

No.8
Doc Name :
User Name :                               I/F Type : Unknown           Job State : Complete
UsedInk : 123.456 ml   Used Paper : 12345 mm (w) x 12345 mm (h)
Print Start Time : 00/00/0000 : 00           Used Time : 12345678 min

No.9
Doc Name :
User Name :                               I/F Type : Unknown           Job State : Complete
UsedInk : 123.456 ml   Used Paper : 12345 mm (w) x 12345 mm (h)
Print Start Time : 00/00/0000 : 00           Used Time : 12345678 min

```

Figure 1-13. Job information print pattern

1.4.3.18 Firmware version

Firmware version is displayed as following,

Table 1-34.

Model	Display
Stylus Pro 7600	VERSION BNxxxx P(orD)
Stylus Pro 9600	VERSION BWxxxx P(orD)

Note 1: xxxx:interface controller version (4 letters)

2: N=Narrow machine: Stylus Pro 7600
W=Wide machine: Stylus Pro 9600

3: The character on the right of lower line represents Dye/Pigment mode.
P: Pigment mode, D: Dye mode

1.4.3.19 Printable pages of each ink cartridge

Printable sheets (estimation) of installed each ink cartridge are displayed.

The formula is following;

Printable sheets = ink remain after print / ink used

Note 1: Printable pages within IR command range are calculated and displayed.

2: When there is no value to be displayed, the panel displays “---”.

1.4.3.20 Ink remaining

Table 1-35.

Ink remaining	Panel display	Ink end LED
100 ~ 81% remaining	E*****F	Off
80 ~ 61% remaining	E**** F	Off
60 ~ 41% remaining	E*** F	Off
40 ~ 21% remaining	E** F	Off
20% ~ just before near end	E* F	Off
After near end ~ just before ink end	nn%	Blink
ink end	0%	On

Note 1: After ink remaining is near end, the ink remaining is displayed with % on the panel. 0% is displayed on the panel for ink end.

2: When initial filling is done by user after the package opened, ink consumption for initial filling is subtracted, and ink remaining of each ink cartridge is displayed as 100%. Ink use count is started at that time. When ink cartridge is replaced, ink use is counted/ displayed according to “Ink system specifications.”

1.4.3.21 Maintenance tank count

How to calculate
Present available rate of maintenance tank is displayed.

Display
Available rate

100 ~ 81%	E*****F
80 ~ 61%	E**** F
60 ~ 41%	E*** F
40 ~ 21%	E** F
20% ~ 10%	E* F
Less than 10% remaining	nn%
0%	0%

Note : When initial filling is done by user after the package opened, maintenance tank indicator is displayed with E*****F for 100~71% remaining and E**** F for 70~61%.

- Warning
When available rate is less than 10% (Total capacity 1300g), Maintenance tank almost full warning occurs. The Maintenance Tank LED blinks.
- Error
When available rate becomes 0, Maintenance tank full error occurs. The Maintenance Tank LED lights up.
- Counter clear
It is cleared with replacing maintenance tank.

1.4.3.22 Use counter

- Ink used
Ink used with following operations is counted;
 - Print operation (irrespective of completion/discontinuation of printing)
 - All flushing operation
 - All cleaning operation

NOTE 1: Ink used within IR command range is accumulated and displayed.
2: When there is no value to be displayed, the panel displays “---”.

- Paper used
Paper used (paper fed) with print operation is displayed in centimeter. Manual paper feeding is not counted.

NOTE 1: Paper used within JS ~ JE command range is accumulated and displayed.
2: When there is no value to be displayed, the panel displays “---”.

1.4.3.23 Clear use counter

- Clear ink used counter
Reset “Ink used” to 0.
- Clear paper used counter
Reset “Paper used” to 0.

1.4.3.24 Job history display

- Job NO.
It is a Job number saved in the printer. The latest job is NO.0.
- Paper use
Paper use of each job is displayed. (Area in m2)

NOTE: Paper use is counted from JS command to JE command.

- Ink use
Ink use of each job is displayed.

NOTE 1: Ink use is counted within IR command or it is counted from JS command to JE command.
2: When IR command is not set, ink use is not counted, and display value is not changed.
3: When there is no value to display, “---” is displayed.

1.4.3.25 Job history clear

With this menu, job history saved in the printer is cleared. Ink use and paper use of job history are displayed “---”.

1.4.3.26 Total prints

Total prints are displayed in decimal. (Max. 6 figures)

1.4.3.27 Consumables life

❑ Cutter life

■ How to calculate

The number of times the cutter has been used is calculated by counting down from 2000. The count is reduced by one every time one sheet is cut irrespective of paper sizes.

The counter is cleared at replacing the cutter with a new one.

■ Display (Life)

100 ~ 81%	E*****F
80 ~ 61%	E**** F
60 ~ 41%	E*** F
40 ~ 21%	E** F
20% ~ 1%	E* F
Less than 1% remaining	F F

■ Maintenance Req.

Not happen, because

- Cutter condition can be checked with cutting.
- It doesn't cause big obstacles.
- Users can replace a cutter easily.

■ Fatal error

Not happen.

■ Counter clear

The counter is cleared at replacing the cutter with a new one.

❑ CR motor life monitor

■ How to calculate

It is displayed with tube life (B1 width), because tube friction causes CR motor trouble. The tube life is calculated with the number of CR scan times.

Table 1-36. Reference value

Printer Model	Number of Passes	Condition
Stylus Pro 7600	250 million passes	B0/ Speed
Stylus Pro 9600	325 million passes	A1/ Speed

Note : 1 pass = 1 round trip

■ Display (Life)

100 ~ 81%	E*****F
80 ~ 61%	E**** F
60 ~ 41%	E*** F
40 ~ 21%	E** F
20% ~ 1%	E* F
Less than 1% remaining	F F

■ Maintenance Req.

It is happened when the life is less than 4%.

■ Fatal error

When the remainder of the life is judged to be 0 by taking into account damage to the tube, service call occurs.

■ Counter clear

When “CLEAR COUNTERS CR MOTOR” or “CLEAR COUNTERS CR TOTAL” in Maintenance mode 2 is executed, the counter is cleared.



The indication as described above may not be accurate depending on the conditions of use, thus it is given only as a yardstick.



Information on these values is needed only when service personnel perform maintenance work. Do not inform users of the meaning of these indications.

□ PF motor life monitor

■ How to calculate

It is calculated for trouble examination in case that it is used beyond production life, because parts of PF motor and paper feeding drive mechanism are not supported to exchange within production life. It is displayed with ratio of PF roller life and driven roller life, because their lives are shorter than PF motor. PF roller life and driven roller life are calculated with total paper feeding, because their lives are defined with paper feeding (positive direction/negative direction).

■ Display (Life)

100 ~ 81%	E*****F
80 ~ 61%	E**** F
60 ~ 41%	E*** F
40 ~ 21%	E** F
20% ~ 1%	E* F
Less than 1% remaining	F F

■ Maintenance Req.

Not happen because it is out of service range within product life.

■ Fatal error

Not happen, because trouble mode is not Fatal.

■ Counter clear

When “CLEAR COUNTERS PF MOTOR” in Maintenance mode 2 is executed, the counter is cleared.

■ Count continuance

Even if remaining is 0, it keeps counting until 32bit register is full, and stops counting-up at the maximum of positive number. It counts not only with panel display but also with trouble analysis from NVRAM detailed data.



Information on these values is needed only when service personnel perform maintenance work. Do not inform users of the meaning of these indications.

□ Head unit life monitor

■ How to calculate

The numbers of dot injection for each color are added up, the number of injecting assured dots per nozzle × 96 nozzles is calculated as the life, and it is calculated with the most number of total dots in each

■ Display (Life)

100 ~ 81%	E*****F
80 ~ 61%	E**** F
60 ~ 41%	E*** F
40 ~ 21%	E** F
20% ~ 1%	E* F
Less than 1% remaining	F F

■ Maintenance Req.

Maintenance request happens at 2.8 billion shot/Nozzle.

■ Fatal error

Not happen as a head unit.

■ Counter clear

When “CLEAR COUNTERS HEAD” in Maintenance mode 2 is executed, the counter is cleared.

■ Count continuance

Same as PF motor.



Information on these values is needed only when service personnel perform maintenance work. Do not inform users of the meaning of these indications.

1.4.3.29 Ink remaining indicator display

Ink remaining indicator is displayed on the lower line of LCD panel.

- LCD display item and LCD panel display position







Ink type	Panel display position
Black1	8 th on the lower line
Black2	9 th on the lower line
Cyan	10 th on the lower line
Magenta	11 th on the lower line
Light Cyan	12 th on the lower line
Light Magent	13 th on the lower line
Yellow	14 th on the lower line
Maintenance*1	16 th on the lower line

Note : It is counted from the left side

- Printer status at indicator display

Status	LCD panel display
Ready to print	READY
Processing data	PRINTING
Ink low	INK LOW
Ink end	INK OUT
Pause	PAUSE

- Ink remaining display and font

Ink remaining	LCD panel display
100 ~ 81% remaining*2	
80 ~ 61% remaining*3	
60 ~ 41% remaining	
40 ~ 21% remaining	
20% remaining ~ just before near end	
Ink end	

Note 1: Available quantity is displayed for the maintenance tank.

- 2: When initial filling is done by user after the package opened, ink consumption for initial filling is subtracted, and ink remaining of each ink cartridge is displayed as 100%. Ink use count is started at that time. When ink cartridge is replaced, ink use is counted/ displayed according to “Ink system specifications.”
- 3: When initial filling is done by user after the package opened, maintenance tank indicator is displayed with “h01” font for 100~76% remaining and “h03” font for 75~61%.



After detection of “Ink Low”, the display is changed from a graph to a% indication.

1.4.3.30 Job information

□ Definition of Job

The minimum unit of printer operation is defined as “Job” with this printer. The job print information with character/image can be saved as a record.

Basic print job functions are followings;

Note "*": Cleaning is not defined as a Job, because it can be executed during printing.

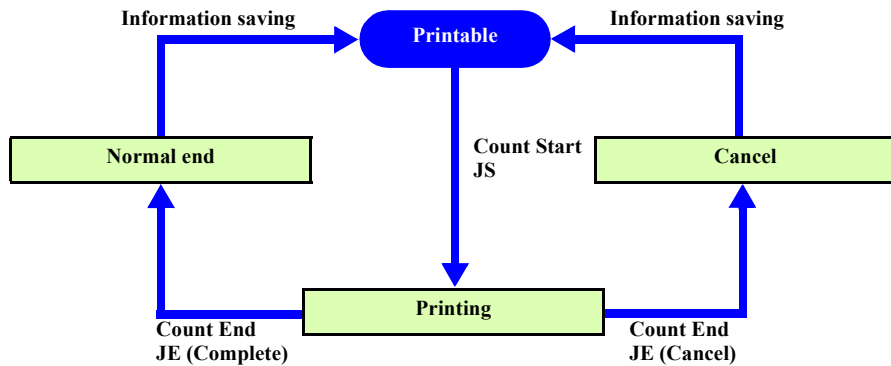

Figure 1-14. Printing Job Transition

□ Job information

This printer saves following job information (68byte × 10job) in NVRAM.

Table 1-37. Job information

Information	Explanation	Range	Capacity	
The quantity of saved job information	The quantity of saved job information in NVRAM	0~10	1byte	
Information No.	Saving order	0~9	1byte	
ID No.	Job ID No.	0~255(••,255,0,1,•••)	1byte	
Using I/F	Using I/F type	00:Unknown 01:Parallel 02:USB 03:Option I/F FF:I/F is not used	1byte	
Job status	Current job status	00:Unknown 01:Printing 02:Complete 03:Abort	1byte	
Character strings code	Character code recognizing code	*	2byte	
Job ID	Job name consisting of host name and document name	User name 16byte Document name 32Byte	48byte	
Ink used	Ink used quantity for intended job [ml]	0~65.535 ml	2byte	
Paper used	Paper used quantity for intended job	Vertical [mm]	0~65535	2byte
		Horizontal [mm]	0~65535	2byte
Print start time	Print start time [Year/month/date/hour/minute]	2255/12/31/24/59[MAX]	5byte	
Time used for print	Time used for print [sec]	0~65535	2byte	
Total			68byte	

Note "*": 00h 00h fixed as Reserve for now.

1.4.3.31 User Paper Setting

Selecting this mode allows detection of the thickness of the available paper, and registration of up to four user-defined paper. Paper feeding adjustment, ink drying time, cutting method, MW print adjustment and suction may be registered for each paper format.

Setting

1. Select user paper setting menu from the panel.
2. Select the paper number ('STD', '1'~'10')
3. Print the paper thickness detection pattern.
4. Check the printed adjustment patterns and enter the number of the pattern with the least displacement for each adjustment item. (See p.58)

Table 1-38. Relationship between Pattern Numbers and Paper Thickness

Number	1	2	3	4	5	6	7	8	9	10	11	12	13	14	15	16	17
Paper thickness	0.0	0.1	0.2	0.3	0.4	0.5	0.6	0.7	0.8	0.9	1.0	1.1	1.2	1.3	1.4	1.5	1.6

5. Enter cutting pressure.
6. Select cutting method.
7. Enter the paper feeding adjustment value.
8. Enter the ink drying time for each pass.
9. Select paper suction.
10. Select MW print quality adjustment.

NOTE 1: Paper setting can be made independently for any paper number.
2: For details of patterns, refer to "Print paper thickness detection pattern (p. 58)".

Paper setting and corresponding operation are as follows.

Table 1-39.

Paper setup	Operation
Standard	When settings of cutting pressure ~ print quality are set with commands, it follows the settings.
1 ~ 10	User definition paper. Even when cutting pressure ~ print quality are set with commands, user setting value is used.

Details of each setting item are following;

Table 1-40.

Setting	Operation
Paper thickness	Print paper thickness detection pattern and enter the paper thickness number. (When "STD" is selected, it is not executed.) *1
Cutting pressure	Paper cutting pressure is set. Lower the pressure for thin and soft paper. Manufacture setting value (75%) is displayed as 100%, which is the maximum setting value to be assured. Setting available range is 110%~0%.
Cutting method	Cutting method is selected, 4 step cutting for thin and soft paper. Paper feed adjustment Paper feeding is adjusted. When 0.00% is not selected for paper feed adjustment, it ignores driver command (SN 03H 00H 00H 04H m2) and setting value with SN menu of Maintenance mode1, and uses this setting value.
Ink drying time	Ink drying time for each pass is set.- The carriage stops at the right/left sides of paper for setting time.
Paper suction	Paper suction is set to make paper stable on the platen. Select "LOW" for thin paper (film), which is difficult to feed.
MW print adjustment	Micro weave mode is adjusted. When print speed has priority, lower the setting value. When quality has priority, raise the setting value.*2

Note 1: When "STD" is selected for Paper selection, Paper thickness detection pattern print, Paper thickness number selection, Paper feeding adjustment setting items are not displayed. Only when Paper "1" ~ "10" is selected, they are displayed.

2: During pattern printing, "PRINTING ALGNMNT PATTERN" is displayed. (<n> is new line)

3: Default display of paper thickness number selection is the number same as gap adjustment.

Note *1: See "MW Printing Adjustment / Setting Values and Printing Modes (p.88)" for selectable MW mode at MW print adjustment.

*2: It prints with PG small or PG big depending on detection result of paper thickness sensor.

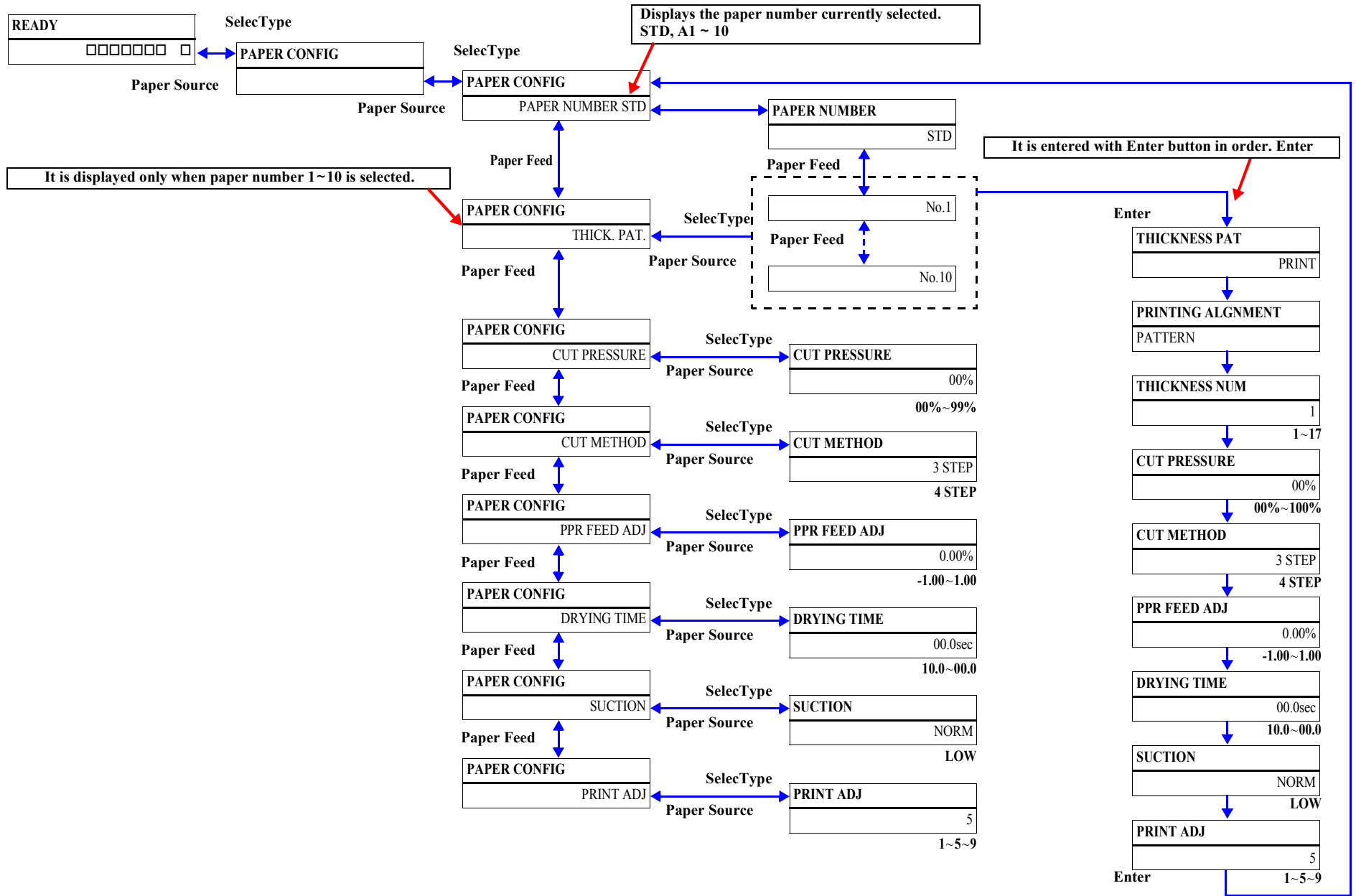

Figure 1-15. Level Structure of User Setting Menu

PRINT PAPER THICKNESS DETECTION PATTERN

Printing Specifications

Table 1-41.

Head speed	240 cps
Pattern height	96 dots
Color	Black
Print direction	Upper patterns: Leftward Lower patterns: Rightward
Pattern interval	Upper patterns: Equal intervals Lower patterns: Centered on base position for gap adjustment value, and displaced by an equal distance left and right. Details are described in next clause.

Relationship between numbers in print pattern and paper thickness.

Table 1-42.

Numbers in print pattern	1	2	3	15	16	17
Paper thickness (mm)	0.0	0.1	0.2	1.4	1.5	1.6

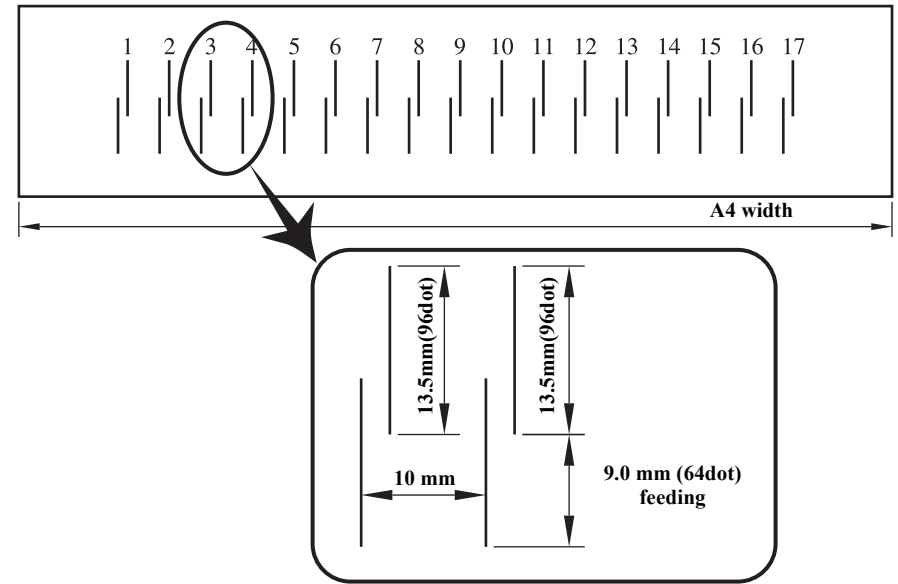

pattern11.eps

Figure 1-16. Paper Thickness Detection Pattern

□ Displacement of bottom pattern
 If the displacement in the gap adjustment value with a change of 0.1 mm in paper thickness is assumed to be X microns, the following applies.

- AB: Gap adjustment value with paper thickness +0.1 mm
- AC: Current gap adjustment value
- AD: Gap adjustment value with paper thickness -0.1 mm

A fixed displacement is assumed with changes in paper thickness.

$$X = AC - AB = AD - AC$$

This adjustment value is saved into NVRAM and can be changed.

Example: With 0.2 mm gap adjustment paper thickness.

Table 1-43.

Pattern number	Displacement of bottom pattern relative to top pattern	Pattern number	Displacement of bottom pattern relative to top pattern
1	+2X	10	-7X
2	+1X	11	-8X
3	± 0	12	-9X
4	-1X	13	-10X
5	-2X	14	-11X
6	-3X	15	-12X
7	-4X	16	-13X
8	-5X	17	-14X
9	-6X		

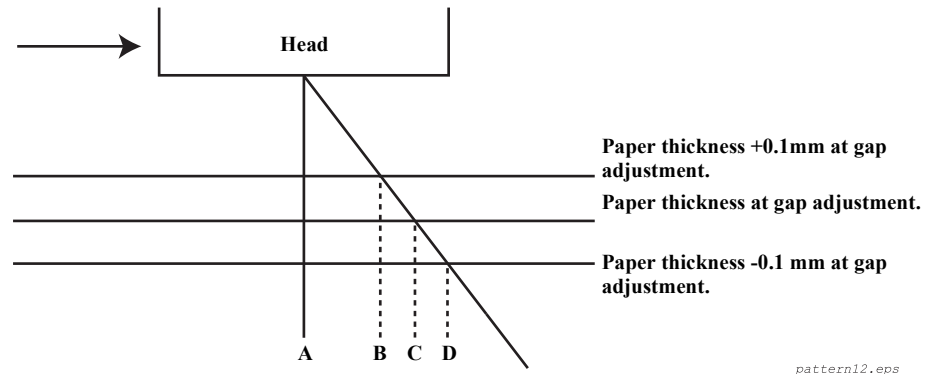

Figure 1-17. Displacement of Paper Thickness Detection Pattern

pattern12.eps

1.4.3.32 Power cleaning

With this mode, the printer has more power cleaning than normal cleaning.

1.4.3.33 Cutter Blade Replacement

Selecting this mode allows the user to replace the cutter blade.

The procedure for cutter blade replacement is as follows:

1. Select the cutter replacement menus from the panel. (The cutter replacement menu can be selected by pressing the SelecType button for 5 sec.)
2. Open the cover following cover open guide.
3. Replace the cutter blade following cutter replacement guide.
4. Close the cover following cover close guide.

1.4.3.34 Gap Adjustment (Bi-D Adjustment, Uni-D Adjustment)

Selecting this mode allows the user to adjust Bi-D and Uni-D depending on paper thickness.

Setting

1. Set the paper.
2. Select the gap adjustment menu from the panel.
3. Set to 'STD' for 0.2mm or 1.2mm EPSON paper. When other paper is set individually, set thickness in units of 0.1mm.
4. Select the adjustment pattern to be printed (Bi-D Black, Bi-D all or Uni-D individual), and print. ("PRINTING ALGNMNT PATTERN" is displayed.)
5. Check the printed adjustment patterns and enter the number of the pattern with the least displacement for each adjustment item.
6. Repeat (4)~(5) until adjustment of all items is completed.

NOTE: For details of patterns, refer to "Gap Adjustment Print Pattern (TBD) (p. 63)".

Adjustment

The adjustment values set above are saved in NVRAM as 4 types of adjustment value depending on PG height (0.7mm/1.2mm/2.2mm/2.6mm). To calculate adjustment value, PG height and paper thickness are necessary. Saving place of adjustment value is selected as following list. Adjustment value saved in NVRAM is updated when the value is adjusted again;

Table 1-44.

Paper thickness sensor	Paper thickness setting	PG setting	Saving place	Notes	
Less than 0.7mm	STD	-	For PG1.2mm	*1	
More than 0.7mm		-	PG2.6mm		
Less than 0.3mm	0S	-	For film media (PG0.7mm)	*2	
More than 0.3mm		*6			
Less than 0.3mm	3S	-	For glossy media (PG0.7mm)	*3	
More than 0.3mm		*7			
Less than 0.3mm	0.0mm	Narrow	For PG0.7mm		
		Standard	For PG0.7mm		
		Wide	For PG1.2mm		
		Wider	For PG2.2mm		
	0.1~0.6mm	Narrow	For PG0.7mm		
		Standard	For PG1.2mm		
		Wide	For PG2.2mm		
		Wider	For PG2.6mm		
	0.7~1.6mm	-	For PG2.6mm	*4	
	More than 0.3mm Less than 0.7mm	0.0~0.6mm	Narrow	For PG1.2mm	
			Standard	For PG1.2mm	
			Wide For	PG2.2mm	
Wider			For PG2.6mm		
0.7~1.6mm		-	For PG2.6mm	*4	
More than 0.7mm	0S/3S/ 0.0~1.6mm	-	For PG2.6mm	*5	

Note 1: Paper thickness is saved to adjust with 0.1mm unit for paper thickness setting command PH.

2: Paper thickness is firstly entered to reduce operation with the closest pattern print of adjustment value saved in the printer.

3: Select "STD" when authentic EPSON dedicated paper is to be used. Then the paper thickness sensors detect the paper thickness and make automatic setting.
(Thin paper = 0.2mm / Thick paper = 1.2mm)

4: When the following paper is to be used, select [0S] or [3S].

[0S] = Films and special thin paper

[3S] = Recommended thick RC paper for borderless printing

5: When any paper other than authentic EPSON dedicated paper is to be used, set paper thickness in increments of 0.1 mm.

Note *1: Adjustment values calculated with PG1.2mm for PG 0.7mm, 2.2mm, 2.6mm are saved except adjustment value saved for PG 1.2mm at that time.

*2: In this case, adjustment value is saved into PG0.7mm area as a special setting for film media (paper thickness 0.15mm). This is used when special setting for film media (00h) is set with PH command.

*3: In this case, adjustment value is saved into PG0.7mm area as a special setting for glossy media (paper thickness 0.3mm). This is used when glossy media is specified with paper adjustment value of paper feed adjustment setting command.

*4: Even when paper thickness sensor detects thin paper (less than 0.7mm), PG is set as 2.6mm if paper thickness setting is more than 0.7mm.

*5: When paper thickness sensor detects thick paper (more than 0.7mm), PG is set as 2.6mm regardless of PG setting and paper thickness setting.

*6: It is saved into saving place for paper thickness 0.0mm.

*7: It is saved into saving place for paper thickness 0.3mm.

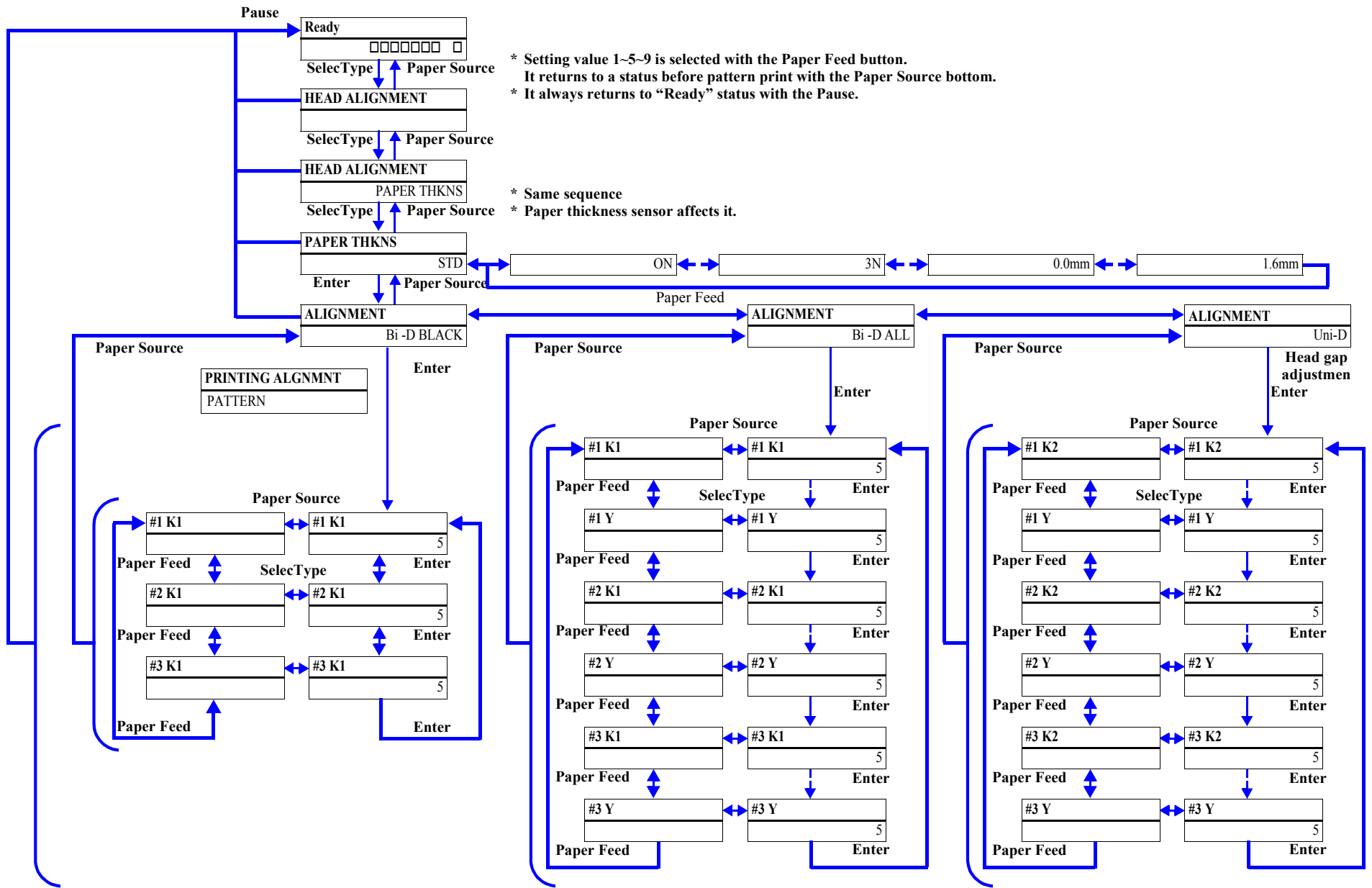

Figure 1-18. Level Structure of Gap Adjustment Menu

GAP ADJUSTMENT PRINT PATTERN (TBD)

- Print specifications
Print specifications of gap adjustment print pattern

Adjusting items	3 items (Refer to next clause for details)
Adjustment pattern height	Bi-D Black (#1, #2, #3) 90mm
	Bi-D All (#1, #2, #3) 220mm
	Uni-D All (#1, #2, #3) 145mm
Adjustment pattern width	Bi-D Black 65mm (24" 3set, 44" 5set)
	Bi-D All 190mm (24" 3set, 44" 5set)
	Uni-D All 185mm (24" 3set, 44" 5set)
Others	When it prints from paper edge, it feeds 100mm for roll paper, 50mm for sheet, and starts printing.

- Each adjustment item

Table 1-45. Adjustment Item List

Adjusting item		Parameter			
		Dot size	Head speed (CPS)	Nozzle No.	
Bi-D All	#1	K1	VSD1	240	1
		K2	VSD1	240	2
		C	VSD1	240	3
		M	VSD1	240	4
		LC	VSD1	240	5
		LM	VSD1	240	6
		Y	VSD1	240	7
	#2	K1	VSD2	240	1
		K2	VSD2	240	2
		C	VSD2	240	3
		M	VSD2	240	4
		LC	VSD2	240	5
		LM	VSD2	240	6
		Y	VSD2	240	7
	#3	K1	VSD4	190	1
		K2	VSD4	190	2
		C	VSD4	190	3
		M	VSD4	190	4
		LC	VSD4	190	5
		LM	VSD4	190	6
		Y	VSD4	190	7

Table 1-45. Adjustment Item List (continued)

Adjusting item		Parameter				
		Dot size	Head speed (CPS)	Nozzle No.		
Uni-D All*1	#1	K2	VSD1	240	2	
		C	VSD1	240	3	
		M	VSD1	240	4	
		LC	VSD1	240	5	
		LM	VSD1	240	6	
		Y	VSD1	240	7	
	#2	K2	VSD2	240	2	
		C	VSD2	240	3	
		M	VSD2	240	4	
		LC	VSD2	240	5	
		LM	VSD2	240	6	
		Y	VSD2	240	7	
	#3	K2	VSD4	190	2	
		C	VSD4	190	3	
		M	VSD4	190	4	
		LC	VSD4	190	5	
		LM	VSD4	190	6	
		Y	VSD4	190	7	
	Bi-D Black	#1	K1	VSD1	240	1
		#2	K1	VSD2	240	1
		#3	K1	VSD4	190	1

Note *1: For Uni-D All (between-row compensation), make each adjustment with the K1 row as the reference.

- The adjustment pattern printing method for each adjustment item is as follows:

Print direction	Bar: Going back and forth every 4dot Block: Upper patterns: Leftward Lower patterns: Rightward
Pattern interval	Upper patterns: equal interval Lower patterns: Print No.5 to be always current setup value. No.5 is standard, and others have adjustment gap as following;

- The relationship between print pattern and adjustment gap is shown below.

Print pattern number	1	2	3	4	5	6	7	8	9
Adjustment gap N/1440 inch (VSD1, VSD2, VSD4)	-4	-3	-2	-1	0	+1	+2	+3	+4

1.4.3.35 BK ink cartridge replacement



- This menu is only displayed for pigment model. It is not displayed for dye model.
- The printer is not turned off during sequence even if Power button is pushed.

1. Select “BK INK CHANGE” in “MAINTENANCE” of panel setting menu and start with “EXEC”.
2. Select changing ink and push the Enter button. (The panel message is depended on installed ink combination at that time.)

LCD panel message: “SELECT INK SET”

Installed ink set	Panel message
MATTE-K+LIGHT-K	#1 PHOTO:#2 LBK
	#1 MAT:#2 MAT
MATTE-K+MATTE-K	#1 MAT:#2 LBK
	#1 PHOTO:#2 LBK (2 cartridges)
PHOTO-K+LIGHT-K	#1 MAT:#2 LBK
	#1 MAT:#2 MAT (2 cartridges)

3. The printer checks available quantity of all color ink remaining for initial filling except changing slot.
 1. When ink remaining is enough, go to (4). When ink remaining is not enough, following message is displayed, and corresponded slot LED blinks.

LCD panel message: “NOT ENOUGH INK”
“RELEASE INK LEVER”

2. Following message is indicated, and corresponded slot LED blinks until lever is released, and new ink cartridge is installed.

LCD panel message: “REPLACE WITH NEW CARTRIDGE”

3. Following message is displayed, when new ink cartridge is installed, and CSIC is contacted.

LCD panel message: “SET INK LEVER”

4. The printer reads CSIC of installed cartridge after the lever is locked.
 - a) When all ink remaining except changing slot is enough for initial filling, go to step 4.
 - b) When wrong ink cartridge is installed, following message is displayed every 1 second, corresponded slot LED blinks, and go back to step 3-2.

LCD panel message: “WRONG CARTRIDGE”
“RELEASE INK LEVER”

- c) When installed ink cartridge is not enough for initial filling, following message is displayed every 1 second, corresponded slot LED blinks, and go back to step 3-2.

LCD panel message: “NOT ENOUGH INK”
“RELEASE INK LEVER”

4. Following messages are displayed every 1 second repeatedly, and all slot LEDs are OFF, after necessary ink remaining for initial filling is checked,

LCD panel message: “REMOVE ALL INK CARTRIDGES”
“RELEASE INK LEVER”

5. Following message is displayed after the lever is released.

LCD panel message: “REMOVE ALL INK CARTRIDGES”

NOTE: The message is indicated until all ink cartridges are removed. LED turns to ON after corresponded cartridge is removed. LEDs except changing slot are ON until cartridges are installed.

6. The printer checks available quantity of maintenance tank, after all cartridges are removed.

NOTE: When 2 cartridges are selected to be changed for procedure (2), it counts available quantity of maintenance tank for 2 cartridges.

1. The printer checks CSIC of maintenance tank. When available quantity is enough, go to step 7. When available quantity is NOT enough, following messages are displayed every 1 second, and maintenance tank LED blinks until maintenance tank is replaced with new one.

LCD panel message: “NOT ENOUGH SPACE IN MAINTENANCE TANK”
“REPLACE WITH NEW MAINTENANCE TANK”

2. The printer checks CSIC after maintenance tank is replaced. When CSIC detects that the maintenance tank have enough available quantity, got to step 7. When available quantity is NOT enough, repeat Procedure step 6-1 and step 6-2.
7. Following messages are displayed every 1 second, and #1 slot LED blinks, after available quantity of maintenance tank is checked.
LCD panel message: **“READY FOR DRAINING”**
“INSERT DRAINING CARTRIDGE IN #X”
8. The printer starts ejecting ink from corresponded ink tube.
 1. Following message is displayed, and XX slot LED blinks, after draining cartridge is installed, and CSIC is connected.
LCD panel message: **“SET INK LEVER”**
 2. The printer checks CSIC after ink lever is set. When the cartridge is correct, go to step 8-3. When the cartridge is wrong, go to step 8-2-1. When the slot is wrong, go to step 8-2-2.
 1. When a cartridge except draining cartridge is installed, following messages are displayed every 1 second, and XX slot LED blinks until the cartridge is removed. Go back to step 8-1.
LCD panel message: **“WRONG CARTRIDGE”**
“RELEASE INK LEVER”
 2. When the cartridge is installed in a slot except XX, following messages are displayed every 1 second, and XX slot LED blinks until the cartridge is removed. Go back to step 8-1.
LCD panel message: **“INSERT CARTRIDGE IN CORRECT SLOT”**
“RELEASE INK LEVER”
 3. Ink ejection starts and following message is displayed.
LCD panel message: **“DRAINING XXX%”** (0%~100%)
 4. Following messages are displayed every 1 second, and XX slot LED blinks, after corresponded ink tube ejection is completed.
LCD panel message: **“REMOVE DRAINING CARTRIDGE”**
“RELEASE INK LEVER”
9. Repeat step 8 when 2 cartridges are replaced. Slot [XX] changes to [K2], and LED shifts to #2.
10. Following message is displayed, and all slots LEDs blink, after the draining cartridge is removed.
LCD panel message: **“INSERT ALL INK CARTRIDGES”**
***NOTE:** Ink remaining for initial filling and wrong cartridge are checked as same as procedure step3*
11. Following message is displayed and all slot LEDs blink after all cartridges are installed, and CSIC is connected.
LCD panel message: **“SET INK LEVER”**
12. Ink filling starts automatically after all ink installation.
LCD panel message: **“INK CHARGING XXX%”**
13. Ink filling completed.
The manufacture logo, ink remaining, and printable pages, which are recorded in replaced ink cartridge CSIC, are displayed.
14. Paper is fed, and cleaning (CL2) is done only for the first printing after ink replacement.

1.4.4 Maintenance Mode 1

OUTLINE

- Startup

The maintenance mode 1 is selected by switching power ON while pushing the Pause button.
- Operation
 1. The setting menu select mode is selected after power ON.
 2. Each setting menu is displayed one after another by pressing Paper Feed Δ ∇ buttons in the setting menu select mode. It is shifted to setting item select menu by pressing the SelecType button. [Setting menu] is displayed on the upper line, and [Setting item] is displayed on the lower line.
 3. The setting menu is displayed one after another by pressing Paper Feed Δ ∇ buttons in the setting item select mode. It is shifted to setting value select mode of the setting item by pressing the SelecType button. [Setting item] is displayed on the upper line, and [Setting value] is displayed on the lower line. The '*' represents the current setup value.
 4. Setting value is displayed on the lower line one after another by pressing Paper Feed Δ ∇ buttons in the setting value select mode if the setting value can be changed. The '*' represents the current setup value.
 5. When the Enter button is pressed in the setting value select mode, the displayed setting value is entered as the current setting value. If it has a corresponded operation, it is started.No operation occurs if '*' is already displayed.
 6. It returns to the setting item select menu by pressing the Paper Source button in the setting value select mode. It returns to the setting menu select mode by pressing the Paper Source button in the setting item select menu.
- Termination
 1. The printer is ready for printing following reset after selecting the panel display language.
 2. Switch power OFF > ON.
- Panel display

Character strings on the second line in "Panel message translation" are displayed on the second line of LCD panel. Setup values are displayed on the second line of LCD panel.

MAINTENANCE MODE 1 SETUP ITEMS

Table 1-46. Maintenance mode 1 setup items

Top menu (Panel display)	Item menu 1 (Panel display)	Item menu 2 (Panel display)	Setup value
Print hexadecimal dump HEX DUMP	- (-)	- (PRINT)	EXEC *1
Panel display language select LANGUAGE -LANGUAGE	- (-)	- (-)	ENGLISH, JAPANESE
Unit change UNIT	- (-)	- (-)	METER, FEET/INCH
Parallel interface mode PARALLEL I/F	- (-)	- (-)	ECP, COMPAT
Set IEEE1284.4 IEEE1284.4	- (-)	- (-)	ON, OFF
Initialize panel setting DEFAULT PANEL	- (-)	- (-)	EXEC
Ink information menu (CRTG INFO MENU)	Ink information (K1) (K1 CARTRIDGE)	Manufacture logo (MANUFACT K1)	EPSON
		Ink color (CARTRIDGE K1)	BLACK / MATTE K / GRAY
		Ink type (INK TYPE K1)	PIGMENT, DYE
		Ink capacity (INK CAP K1)	110ml/220ml
		Ink remaining (INK LEFT-K1)	E****F, E**** F, E*** F,E** F, E* F, E F
		Product date (PROD DATE K1)	<YY>/<MM>
		Expire date (EXPIR DATE K1)	<YY>/<MM>
		Ink life after open (INK LIFE K1)	<MM> Month
Passed time after open (AGE K1)	<MM> Month		

Table 1-46. Maintenance mode 1 setup items (continued)

Top menu (Panel display)	Item menu 1 (Panel display)	Item menu 2 (Panel display)	Setup value
Ink information menu (CRTG INFO MENU)	Ink information (K2) (K2 CARTRIDGE)	Manufacture logo (MANUFACT K2)	EPSON
		Ink color (CARTRIDGE K2)	BLACK / MATTE K / GRAY
		Ink type (INK TYPE K2)	PIGMENT, DYE
		Ink capacity (INK CAP K2)	110ml/220ml
		Ink remaining (INK LEFT-K2)	E*****F, E**** F, E*** F, E** F, E* F, E F
		Product date (PROD DATE K2)	<YY>/<MM>
		Expire date (EXPIR DATE K2)	<YY>/<MM>
		Ink life after open (INK LIFE K2)	<MM> Month
		Passed time after open (AGE K2)	<MM> Month
	Ink information (C) (C CARTRIDGE)	Manufacture logo (MANUFACT C)	EPSON
		Ink color (CARTRIDGE C)	CYAN
		Ink type (INK TYPE C)	PIGMENT, DYE
		Ink capacity (INK CAP C)	110ml/220ml
		Ink remaining (INK LEFT-C)	E*****F, E**** F, E*** F, E** F, E* F, E F
		Product date (PROD DATE C)	<YY>/<MM>
		Expire date (EXPIR DATE C)	<YY>/<MM>
		Ink life after open (INK LIFE C)	<MM> Month
		Passed time after open (AGE C)	<MM> Month

Table 1-46. Maintenance mode 1 setup items (continued)

Top menu (Panel display)	Item menu 1 (Panel display)	Item menu 2 (Panel display)	Setup value
Ink information menu (CRTG INFO MENU)	Ink information (M) (M CARTRIDGE)	Manufacture logo (MANUFACT M)	EPSON
		Ink color (CARTRIDGE M)	MAGENTA
		Ink type (INK TYPE M)	PIGMENT, DYE
		Ink capacity (INK CAP M)	110ml/220ml
		Ink remaining (INK LEFT-M)	E*****F, E**** F, E*** F, E** F, E* F, E F
		Product date (PROD DATE M)	<YY>/<MM>
		Expire date (EXPIR DATE M)	<YY>/<MM>
		Ink life after open (INK LIFE M)	<MM> Month
		Passed time after open (AGE M)	<MM> Month
	Ink information (Lc) (Lc CARTRIDGE)	Manufacture logo (MANUFACT Lc)	EPSON
		Ink color (CARTRIDGE Lc)	LG. CYAN
		Ink type (INK TYPE LC)	PIGMENT, DYE
		Ink capacity (INK CAP LC)	110ml/220ml
		Ink remaining (INK LEFT-LC)	E*****F, E**** F, E*** F, E** F, E* F, E F
		Product date (PROD DATE LC)	<YY>/<MM>
		Expire date (EXPIR DATE LC)	<YY>/<MM>
		Ink life after open (INK LIFE LC)	<MM> Month
		Passed time after open (AGE LC)	<MM> Month

Table 1-46. Maintenance mode 1 setup items (continued)

Top menu (Panel display)	Item menu 1 (Panel display)	Item menu 2 (Panel display)	Setup value
Ink information menu (CRTG INFO MENU)	Ink information (Lm) (Lm CARTRIDGE)	Manufacture logo (MANUFACT Lm)	EPSON
		Ink color (CARTRIDGE Lm)	LGT. MAGENTA
		Ink type (INK TYPE LM)	PIGMENT, DYE
		Ink capacity (INK CAP LM)	110ml/220ml
		Ink remaining (INK LEFT-LM)	E*****F, E**** F, E*** F, E** F, E* F, E F
		Product date (PROD DATE LM)	<YY>/<MM>
		Expire date (EXPIR DATE LM)	<YY>/<MM>
		Ink life after open (INK LIFE LM)	<MM> Month
		Passed time after open (AGE LM)	<MM> Month
	Ink information (Y) (Y CARTRIDGE)	Manufacture logo (MANUFACT Y)	EPSON
		Ink color (CARTRIDGE Y)	YELLOW
		Ink type (INK TYPE Y)	PIGMENT, DYE
		Ink capacity (INK CAP Y)	110ml/220ml
		Ink remaining (INK LEFT-Y)	E*****F, E**** F, E*** F, E** F, E* F, E F
		Product date (PROD DATE Y)	<YY>/<MM>
		Expire date (EXPIR DATE Y)	<YY>/<MM>
		Ink life after open (INK LIFE Y)	<MM> Month
		Passed time after open (AGE Y)	<MM> Month

Table 1-46. Maintenance mode 1 setup items (continued)

Top menu (Panel display)	Item menu 1 (Panel display)	Item menu 2 (Panel display)	Setup value
SN Menu (SN MENU)	Paper feeding adjustment conversion table 1 (User table pigment) (XX1=<nn>:<mm>)	- (-)	<nn> :00H~C9H <mm> :00H~C9H,FFH
	Paper feeding adjustment conversion table 2 (User table dye) (XX2=<nn>:<mm>)	- (-)	<nn> :00H~C9H <mm> :00H~C9H,FFH
	The whole paper feeding adjustment offset (Pigment) (XXO=<nn>)	- (-)	<nn> :-32~0~+32
	The whole paper feeding adjustment offset (Dye) (XXP=<nn>)	- (-)	<nn> :-32~0~+32
	System table version (XXS=<mmmmmm>)	- (-)	<mmmmmm> : F/W Version
	User table version (XXU=<nn>)	- (-)	<nn> :00H~FFH
	Initialize user table (XXI)	- (-)	EXEC

Note *1: When hexadecimal dump mode is executed, "PRINT" is displayed.

HEXADECIMAL DUMP

The hex dump function allows data sent to the printer to be printed and displayed in hexadecimal format. One line contains 16 data items in hexadecimal format, with the equivalent characters printed at the right of each line. If no equipment characters exist (control codes, etc.), a period is printed. It prints every 16 data. It prints the last data with pressing the Pause button, when it is less than 16. Panel setting is not available in the hex dump mode. Using this function, users can check that data has been sent correctly from the computer to the printer. To terminate this mode, stop printing with Pause button and shut off the power.

PANEL DISPLAY LANGUAGE SELECTION

Users can select English, French, Italian, German, Spanish, and Portuguese for display on the LCD with this mode.

UNIT CHANGE

Users can change length unit of LCD panel / pattern print with this mode.

- METER: meter (m)
- FEET/INCH: Feet(ft)/Inch(in)

Unit of following messages can be changed;

Table 1-47.

Item		Message	
		Meter	Feet/Inch
Panel LCD display	Paper counter	xxxxx.xcm	xxxxft xxin
	Job information display (Paper used)	xxxxxxxcm2	xxxxxx.xsqft
Nozzle check pattern	Current Paper Count	xxxxx.xcm	xxxxft xxin
	Previous Paper Count	xxxxx.xcm	xxxxft xxin
Status sheet	Use Paper	xxxxxx.xcm	xxxxft xxin
Job information print	Paper used (vertical)	xxxxxx.xcm	xxxxft xxin
	Paper used (horizontal)	xxxxxx.xcm	xxxxft xxin

Note : This function is available only for English.

PARALLEL I/F MODE

Users can switch parallel I/F receiving speed with this mode; ECP/compatibility

1284.4 SETTING (D4)

Users can set 1284.4mode with this mode ON.

INK INFORMATION MENU

It displays ink information recorded in CSIC.

- Manufacture logo: Manufacture information saved in CSIC of each ink cartridge is displayed.
- Ink Color: Ink color information saved in CSIC of each ink cartridge is displayed.
- Ink Type: Ink type information saved in CSIC of each ink cartridge is displayed.
- Ink capacity: Ink capacity information saved in CSIC of each ink cartridge is displayed.
- Ink remaining: Ink remaining of each ink cartridge is displayed.
- Product date: Product date information saved in CSIC of each ink cartridge is displayed with <YY>/<MM> form.
- Expire date: Ink expire date information saved in CSIC of each ink cartridge is displayed.
- Ink life after open: Ink life information saved in CSIC of each ink cartridge is displayed.
- Passed time after open: Passed time after opened of each ink cartridge is displayed.

NOTE: These are displayed every color (K~Y).

SSN MENU

- Paper feed adjustment table

m2 value set by mechanism sequence command “Paper feed adjustment” is converted to the actual paper feed adjustment value with paper feed adjustment table saved in NVRAM.

(The conversion is valid when mechanism sequence command “Paper feed adjustment mode = ON”.)

Users can change following conversion table with this maintenance mode.

- User table for dye media
- User table for pigment media

- Change of paper feed adjustment table by users

- Format
“XXx=nn:mm”

- <mm> indicates conversion value of <nn> designated with mechanism sequence command
 - Conversion tables are XX1 ~ XX2.
 - When <mm> = FFh, applicable input value is not converted.
 - Operation
 - The cursor shifts between <nn> and <mm> with SelecType button and Paper Source button.
 - The value pointed with the cursor increases/decreases with Paper Feed Δ∇ buttons.
 - Setting value is saved into NVRAM with “Enter” button.
 - Paper feed adjustment offset

Offset value is set to add to the actual paper feed adjustment value. The setup value is always valid regardless of mechanism sequence command “Paper feed adjustment mode” setting.

 - Format

“XX0=<nn>” Bias value is set for pigment.
 - Operation
 - The value increases/decreases with Paper Feed Δ∇ buttons.
 - Setting value is saved into NVRAM with Enter button.
 - System table version

It displays version No. of paper feed adjustment conversion table saved in the printer.
Format:
“XXS=<mmmmm><n>”
- NOTE 1:** <mmmmm> is 5 letters indicating version of engine controller.
(e.g. “0270C”)
- 2:** <n> is 1-figure hexadecimal number indicating change history of conversion table. (e.g. “0”)
- User table version

When a user change the table, the version No. is added 1 optionally.
Format:
“XXU=nn” *<nn> is 2-figure hexadecimal number
 - User table initializing

Users can initialize user table to system table with this mode.

1.4.5 Maintenance Mode 2

OUTLINE

- Startup

The maintenance mode 2 is selected by switching power ON while pushing the Paper source, Cut/Eject, and Paper Feed ∇ buttons.
- Operation
 1. The setting menu select mode is selected after power ON.
 2. Each setting menu is displayed one after another by pressing Paper Feed Δ∇ buttons in the setting menu select mode. It is shifted to setting item select menu by pressing the SelecType button.
[Setting menu] is displayed on the upper line, and [Setting item] is displayed on the lower line.
 3. The setting menu is displayed one after another by pressing Paper Feed Δ∇ buttons in the setting item select mode. It is shifted to setting value select mode of the setting item by pressing the SelecType button. [Setting item] is displayed on the upper line, and [Setting value] is displayed on the lower line. The '*' represents the current setup value.
 4. Setting value is displayed on the lower line one after another by pressing Paper Feed Δ∇ buttons in the setting value select mode if the setting value can be changed. The '*' represents the current setup value.
 5. When the Enter button is pressed in the setting value select mode, the displayed setting value is entered as the current setting value. If it has a corresponded operation, it is started. No operation occurs if '*' is already displayed.
 6. It returns to the setting item select menu by pressing the Paper Source button in the setting value select mode. It returns to the setting menu select mode by pressing the Paper Source button in the setting item select menu.
- Termination

Switch power OFF > ON.
- Panel display

Character strings on the second line in “Panel message translation” are displayed on the second line of LCD panel. Setup values are displayed on the second line of LCD panel.

MAINTENANCE MODE 2 SETUP ITEMS

Table 1-48. Maintenance mode 2 setup items

Top menu (Panel display)	Item menu 1 (Panel display)	Item menu 2	Panel display	Setup value
Counter view menu (VIEW COUNTERS)	Cutter life counter value (CUTTER)	-	-	0~4294967295 (Decimal)
	Cutter life total counter value (CUTTER TOTAL)	-	-	0~4294967295 (Decimal)
	Total prints counter value (TOTAL PAGES)	-	-	0~4294967295 (Decimal)
	Waste ink counter value (MAINTE TANK)	-	-	0~4294967295 (Decimal)
	CR motor life counter value (CR MOTOR)	-	-	0~4294967295 (Decimal)
	CR motor life total counter value (CR TOTAL)	-	-	0~4294967295 (Decimal)
	PF motor life counter value (PF MOTOR)	-	-	0~4294967295 (Decimal)
	Head unit (K1) life counter value (HEAD K1)	-	-	0~4294967295 (Decimal)
	Head unit (K2) life counter value (HEAD K2)	-	-	0~4294967295 (Decimal)
	Head unit (C) life counter value (HEAD C)	-	-	0~4294967295 (Decimal)
	Head unit (M) life counter value (HEAD M)	-	-	0~4294967295 (Decimal)
	Head unit (LC) life counter value (HEAD LC)	-	-	0~4294967295 (Decimal)
	Head unit (LM) life counter value (HEAD LM)	-	-	0~4294967295 (Decimal)
	Head unit (Y) life counter value (HEAD Y)	-	-	0~4294967295 (Decimal)
	Flashing box (FL BOX)	-	-	0~4294967295 (Decimal)
	Cleaning unit life counter value (CLEANER)	-	-	0~4294967295 (Decimal)
Sponge for borderless print counter (SPONGE)	-	-	0~4294967295 (Decimal)	
Counter initialize menu (CLEAR COUNTERS)	Initialize NVRAM, timer, life counter, mechanical counter (INIT ALL)	-	-	EXEC
	Initialize NVRAM (NVRAM)	-	-	EXEC
	Initialize RTC (RTC)	-	-	<YY>/<MM>/<DD>/<HH>
	Initialize cutter life total (CUTTER)	-	-	EXEC
	Initialize CR motor life (CR MOTOR)	-	-	EXEC
	Initialize total CR motor life (CR TOTAL)	-	-	EXEC
	Initialize total PF motor life (PF MOTOR)	-	-	EXEC
	Initialize head unit (HEAD)	-	-	EXEC
	Initialize cleaning unit (CLEANER)	-	-	EXEC
	Initialize total printed pages counter (TOTAL PAGES)	-	-	EXEC
	Initialize waste ink capacity (MAINTE TANK)	-	-	EXEC
	Initialize flashing box (FL BOX)	-	-	0~4294967295 (Decimal)
Initialize sponge for borderless print counter (SPONGE)	-	-	0~4294967295 (Decimal)	

Table 1-48. Maintenance mode 2 setup items (continued)

Top menu (Panel display)	Item menu 1 (Panel display)	Item menu 2	Panel display	Setup value
Adjustment / setup menu (SERVICE CONFIG)	Paper feeding adjustment conversion table 3 (System table pigment) (XX1=<nn>:<mm>)	-	-	<nn> :00H~C9H <mm> :00H~C9H,FFH
	Paper feeding adjustment conversion table 4 (System table dye) (XX2=<nn>:<mm>)	-	-	<nn> :00H~C9H <mm> :00H~C9H,FFH
	System table version (XXS=<mmmmm>)	-	-	<mmmmm> : F/W version
	Parameter backup (BACKUP)	-	-	EXEC
	Device ID change (D-ID)	-	-	For R4C803P StylusPro7600 StylusPro7600D PX-7000 For R4C825P StylusPro9600 StylusPro9600D PX-9000
	nk cartridge type setting (NPD)	-	-	0,1,2
CSIC detection level (ED MODE)	-	-	O/N/X	
Maintenance information menu (MAINTINFO)	Operation time, environment (MENUE)	RTC date	E1	<YY><MM><DD><HH>
		RTC initialized date	E2	<YY><MM><DD><HH>
		Environment temperature	E3	<nn>
		First power ON date	E4	<YY><MM><DD>
		Printer total energization time	E5	<nnnnnnnnnn>
		Energy star non-sleep mode total time	E6	<nnnnnnnnnn>
		Paper sensor total energization time	E7	<nnnnnnnnnn>
		Suction fan total energization time	E8	<nnnnnnnnnn>
		Front cover open/close times	E9	<nnnnnnnnnn>
		Temperature at print less than 15°C	E10	<nnnnnnnnnn>
		Temperature at print 15°C ~ 20°C	E11	<nnnnnnnnnn>
		Temperature at print 20°C ~ 25°C	E12	<nnnnnnnnnn>
		Temperature at print 25°C ~ 30°C	E13	<nnnnnnnnnn>
		Temperature at print 30°C ~ 35°C	E14	<nnnnnnnnnn>
		Temperature at print more than 35°C	E15	<nnnnnnnnnn>
		The highest temperature at print	E16	<nn>
		The lowest temperature at print	E17	<nn>
	Carriage (MENUR)	Carriage total turning times (190~240cps)	R1	<nnnnnnnnnn>
		Carriage total turning times (240cps)	R2	<nnnnnnnnnn>
		Carriage durable parts replacement date	R3	<YY><MM><DD>
		Carriage turning times after durable parts replacement (190~240cps)	R4	<nnnnnnnnnn>
Carriage turning times after durable parts replacement (240cps)		R5	<nnnnnnnnnn>	

Table 1-48. Maintenance mode 2 setup items (continued)

Top menu (Panel display)	Item menu 1 (Panel display)	Item menu 2	Panel display	Setup value
Maintenance information menu (MAINTINFO)	Ink system (MENUS)	Total waste ink counter (sponge)	S1	<nnnnnnn.n>
		Total waste ink counter (flushing box)	S2	<nnnnnnn.n>
		Manual cleaning times	S3	<nnnnnnnnn>
		Cleaning times (CL1)	S4	<nnnnnnnnn>
		Cleaning times (CL2)	S5	<nnnnnnnnn>
		Cleaning times (CL3)	S6	<nnnnnnnnn>
		Cleaning times (CL4)	S7	<nnnnnnnnn>
		Cleaning times (CL5PowerCL)	S8	<nnnnnnnnn>
		Final CL5 cleaning date	S9	<YY><MM><DD>
		Cleaning times (TCL1)	S10	<nnnnnnnnn>
		Cleaning times (TCL2)	S11	<nnnnnnnnn>
		Cleaning times (TCL3)	S12	<nnnnnnnnn>
		Cleaning times (TCL4)	S13	<nnnnnnnnn>
		Ink type replacement times	S14	<nnnnnnnnnn>
		Ink replacement date (last time)	S15	<YY><MM><DD>
		Ink replacement date (2 times before)	S16	<YY><MM><DD>
		Ink type replacement times	S17	<nnnnnnnnnn>
		Ink replacement date (last time)	S18	<YY><MM><DD>
		Ink replacement date (2 times before)	S19	<YY><MM><DD>
		Ink type replacement times	S20	<nnnnnnnnnn>
		Ink replacement date (last time)	S21	<YY><MM><DD>
		Ink replacement date (2 times before)	S22	<YY><MM><DD>
		Ink type replacement times	S23	<nnnnnnnnnn>
		Ink replacement date (last time)	S24	<YY><MM><DD>
		Ink replacement date (2 times before)	S25	<YY><MM><DD>
		Ink type replacement times	S26	<nnnnnnnnnn>
		Ink replacement date (last time)	S27	<YY><MM><DD>
		Ink replacement date (2 times before)	S28	<YY><MM><DD>
		Ink type replacement times	S29	<nnnnnnnnnn>
		Ink type replacement (last time)	S30	<nnnnnnnnnn>
		Ink type replacement (2 times before)	S31	<nnnnnnnnnn>
		Maintenance tank replacement times	S32	<nnnnnnnnn>
		Maintenance tank replacement date (this time)	S33	<YY><MM><DD>
		Maintenance tank replacement date (last time)	S34	<YY><MM><DD>
		Maintenance tank replacement date (2 times before)	S35	<YY><MM><DD>

Table 1-48. Maintenance mode 2 setup items (continued)

Top menu (Panel display)	Item menu 1 (Panel display)	Item menu 2		Panel display	Setup value	
Maintenance information menu (MAINTINFO)	Ink 1 (MENUA)	Total ink use	EPSON genuine ink	P.K(K in slot 1 for dye model)	A1	<nnnnnnnnnn>
		Total ink use	EPSON genuine ink	L.K(K in slot 2 for dye model)	A2	<nnnnnnnnnn>
		Total ink use	EPSON genuine ink	M.K	A3	<nnnnnnnnnn>
		Total ink use	Others	Slot 1	A4	<nnnnnnnnnn>
		Total ink use	Others	Slot 2	A5	<nnnnnnnnnn>
		Total ink use	EPSON genuine ink	C	A6	<nnnnnnnnnn>
		Total ink use	Others	C	A7	<nnnnnnnnnn>
		Total ink use	EPSON genuine ink	M	A8	<nnnnnnnnnn>
		Total ink use	Others	M	A9	<nnnnnnnnnn>
		Total ink use	EPSON genuine ink	LC	A10	<nnnnnnnnnn>
		Total ink use	Others	LC	A11	<nnnnnnnnnn>
		Total ink use	EPSON genuine ink	LM	A12	<nnnnnnnnnn>
		Total ink use	Others	LM	A13	<nnnnnnnnnn>
		Total ink use	EPSON genuine ink	Y	A14	<nnnnnnnnnn>
		Total ink use	Others	Y	A15	<nnnnnnnnnn>
		Ink cartridge replacement times	P.K(K in slot 1 for dye model)	110ml	A16	<nnnnnnnnnn>
		Ink cartridge replacement times	P.K(K in slot 1 for dye model)	220ml	A17	<nnnnnnnnnn>
		Ink cartridge replacement times	L.K(K in slot 2 for dye model)	110ml	A18	<nnnnnnnnnn>
		Ink cartridge replacement times	L.K(K in slot 2 for dye model)	220ml	A19	<nnnnnnnnnn>
		Ink cartridge replacement times	M.K	110ml	A20	<nnnnnnnnnn>
		Ink cartridge replacement times	M.K	220ml	A21	<nnnnnnnnnn>
		Ink cartridge replacement times	C	110ml	A22	<nnnnnnnnnn>
		Ink cartridge replacement times	C	220ml	A23	<nnnnnnnnnn>
		Ink cartridge replacement times	M	110ml	A24	<nnnnnnnnnn>
		Ink cartridge replacement times	M	220ml	A25	<nnnnnnnnnn>
		Ink cartridge replacement times	LC	110ml	A26	<nnnnnnnnnn>
		Ink cartridge replacement times	LC	220ml	A27	<nnnnnnnnnn>
		Ink cartridge replacement times	LM	110ml	A28	<nnnnnnnnnn>
		Ink cartridge replacement times	LM	220ml	A29	<nnnnnnnnnn>
		Ink cartridge replacement times	Y	110ml	A30	<nnnnnnnnnn>
		Ink cartridge replacement times	Y	220ml	A31	<nnnnnnnnnn>

Table 1-48. Maintenance mode 2 setup items (continued)

Top menu (Panel display)	Item menu 1 (Panel display)	Item menu 2	Panel display	Setup value
Maintenance information menu (MAINTINFO)	Ink 2 (MENUB)	Each color ink replacement date (Black1, this time)	B1	<YY><MM><DD>
		Each color ink vendor (Black1, this time)	B2	<XXXXXXXXXXXXXXXXXX>
		Each color ink replacement date (Black1, last time)	B3	<YY><MM><DD>
		Each color ink vendor (Black1, last time)	B4	<XXXXXXXXXXXXXXXXXX>
		Each color ink replacement date (Black1, 2 times before)	B5	<YY><MM><DD>
		Each color ink vendor (Black1, 2 times before)	B6	<XXXXXXXXXXXXXXXXXX>
		Each color ink replacement date (Black2, this time)	B7	<YY><MM><DD>
		Each color ink vendor (Black2, this time)	B8	<XXXXXXXXXXXXXXXXXX>
		Each color ink replacement date (Black2, last time)	B9	<YY><MM><DD>
		Each color ink vendor (Black2, last time)	B10	<XXXXXXXXXXXXXXXXXX>
		Each color ink replacement date (Black2, 2 times before)	B11	<YY><MM><DD>
		Each color ink vendor (Black2, 2 times before)	B12	<XXXXXXXXXXXXXXXXXX>
		Each color ink replacement date (Cyan, this time)	B13	<YY><MM><DD>
		Each color ink vendor (Cyan, this time)	B14	<XXXXXXXXXXXXXXXXXX>
		Each color ink replacement date (Cyan, last time)	B15	<YY><MM><DD>
		Each color ink vendor (Cyan, last time)	B16	<XXXXXXXXXXXXXXXXXX>
		Each color ink replacement date (Cyan, 2 times before)	B17	<YY><MM><DD>
		Each color ink vendor (Cyan, 2 times before)	B18	<XXXXXXXXXXXXXXXXXX>
		Each color ink replacement date (Magenta, this time)	B19	<YY><MM><DD>
		Each color ink vendor (Magenta, this time)	B20	<XXXXXXXXXXXXXXXXXX>
		Each color ink replacement date (Magenta, last time)	B21	<YY><MM><DD>
		Each color ink vendor (Magenta, last time)	B22	<XXXXXXXXXXXXXXXXXX>
		Each color ink replacement date (Magenta, 2 times before)	B23	<YY><MM><DD>
		Each color ink vendor (Magenta, 2 times before)	B24	<XXXXXXXXXXXXXXXXXX>
		Each color ink replacement date (LgtCyan, this time)	B25	<YY><MM><DD>
		Each color ink vendor (LgtCyan, this time)	B26	<XXXXXXXXXXXXXXXXXX>
		Each color ink replacement date (LgtCyan, last time)	B27	<YY><MM><DD>
		Each color ink vendor (LgtCyan, last time)	B28	<XXXXXXXXXXXXXXXXXX>
		Each color ink replacement date (LgtCyan, 2 times before)	B29	<YY><MM><DD>
		Each color ink vendor (LgtCyan, 2 times before)	B30	<XXXXXXXXXXXXXXXXXX>
		Each color ink replacement date (LgtMagenta, this time)	B31	<YY><MM><DD>
		Each color ink vendor (LgtMagenta, this time)	B32	<XXXXXXXXXXXXXXXXXX>
		Each color ink replacement date (LgtMagenta, last time)	B33	<YY><MM><DD>
		Each color ink vendor (LgtMagenta, last time)	B34	<XXXXXXXXXXXXXXXXXX>
		Each color ink replacement date (LgtMagenta, 2 times before)	B35	<YY><MM><DD>
		Each color ink vendor (LgtMagenta, 2 times before)	B36	<XXXXXXXXXXXXXXXXXX>
		Each color ink replacement date (Yellow, this time)	B37	<YY><MM><DD>

Table 1-48. Maintenance mode 2 setup items (continued)

Top menu (Panel display)	Item menu 1 (Panel display)	Item menu 2	Panel display	Setup value
Maintenance information menu (MAINTINFO)	Ink 2 (MENUB)	Each color ink vendor (Yellow, this time)	B38	<XXXXXXXXXXXXXXXXXX>
		Each color ink replacement date (Yellow, last time)	B39	<YY><MM><DD>
		Each color ink vendor (Yellow, last time)	B40	<XXXXXXXXXXXXXXXXXX>
		Each color ink replacement date (Yellow, 2 times before)	B41	<YY><MM><DD>
		Each color ink vendor (Yellow, 2 times before)	B42	<XXXXXXXXXXXXXXXXXX>

Table 1-48. Maintenance mode 2 setup items (continued)

Top menu (Panel display)	Item menu 1 (Panel display)	Item menu 2	Panel display	Setup value
Maintenance information menu (MAINTINFO)	Paper (MENUP)	Roll paper setting times	P1	<nnnnnnnn>
		Sheets setting times	P2	<nnnnnnnn>
		Print length of each paper size (Roll paper width 1)	P3	<nnnnnnnn>
		Paper ejection times of each paper size (Roll paper width 1)	P4	<nnnnnnnn>
		Print length of each paper size (Roll paper width 2)	P5	<nnnnnnnn>
		Paper ejection times of each paper size (Roll paper width 2)	P6	<nnnnnnnn>
		Print length of each paper size (Roll paper width 3)	P7	<nnnnnnnn>
		Paper ejection times of each paper size (Roll paper width 3)	P8	<nnnnnnnn>
		Print length of each paper size (Roll paper width 4)	P9	<nnnnnnnn>
		Paper ejection times of each paper size (Roll paper width 4)	P10	<nnnnnnnn>
		Print length of each paper size (Roll paper width 5)	P11	<nnnnnnnn>
		Paper ejection times of each paper size (Roll paper width 5)	P12	<nnnnnnnn>
		Print length of each paper size (Roll paper width 6)	P13	<nnnnnnnn>
		Paper ejection times of each paper size (Roll paper width 6)	P14	<nnnnnnnn>
		Print length of each paper size (Roll paper width 7)	P15	<nnnnnnnn>
		Paper ejection times of each paper size (Roll paper width 7)	P16	<nnnnnnnn>
		Print length of each paper size (Roll paper width 8)	P17	<nnnnnnnn>
		Paper ejection times of each paper size (Roll paper width 8)	P18	<nnnnnnnn>
		Print length of each paper size (Roll paper width 9)	P19	<nnnnnnnn>
		Paper ejection times of each paper size (Roll paper width 9)	P20	<nnnnnnnn>
		Print length of each paper size (Roll paper width 10)	P21	<nnnnnnnn>
		Paper ejection times of each paper size (Roll paper width 10)	P22	<nnnnnnnn>
		Print length of each paper size (Sheet width 1)	P23	<nnnnnnnn>
		Paper ejection times of each paper size (Sheet width 1)	P24	<nnnnnnnn>
		Print length of each paper size (Sheet width 2)	P25	<nnnnnnnn>
		Paper ejection times of each paper size (Sheet width 2)	P26	<nnnnnnnn>
		Print length of each paper size (Sheet width 3)	P27	<nnnnnnnn>
		Paper ejection times of each paper size (Sheet width 3)	P28	<nnnnnnnn>
		Print length of each paper size (Sheet width 4)	P29	<nnnnnnnn>
		Paper ejection times of each paper size (Sheet width 4)	P30	<nnnnnnnn>
		Print length of each paper size (Sheet width 5)	P31	<nnnnnnnn>
		Paper ejection times of each paper size (Sheet width 5)	P32	<nnnnnnnn>
		Print length of each paper size (Sheet width 6)	P33	<nnnnnnnn>

Table 1-48. Maintenance mode 2 setup items (continued)

Top menu (Panel display)	Item menu 1 (Panel display)	Item menu 2		Panel display	Setup value	
Maintenance information menu (MAINTINFO)	Paper (MENU)	Paper ejection times of each paper size (Sheet width 6)		P34	<nnnnnnnn>	
		Print length of each paper size (Sheet width 7)		P35	<nnnnnnnn>	
		Paper ejection times of each paper size (Sheet width 7)		P36	<nnnnnnnn>	
		Print length of each paper size (Sheet width 8)		P37	<nnnnnnnn>	
		Paper ejection times of each paper size (Sheet width 8)		P38	<nnnnnnnn>	
		Print length of each paper size (Sheet width 9)		P39	<nnnnnnnn>	
		Paper ejection times of each paper size (Sheet width 9)		P40	<nnnnnnnn>	
		Print length of each paper size (Sheet width 10)		P41	<nnnnnnnn>	
		Paper ejection times of each paper size (Sheet width 10)		P42	<nnnnnnnn>	
	Print mode (MENU)	Print mode setting times	2880-1440	Uni-D	M1	<nnnnnnnn>
		Print mode setting times	1440-0720	Uni-D	M2	<nnnnnnnn>
		Print mode setting times	720-720	Uni-D	M3	<nnnnnnnn>
		Print mode setting times	720-360	Uni-D	M4	<nnnnnnnn>
		Print mode setting times	360-720	Uni-D	M5	<nnnnnnnn>
		Print mode setting times	Others	Uni-D	M6	<nnnnnnnn>
		Print mode setting times	2880-1440	Bi-D	M7	<nnnnnnnn>
		Print mode setting times	1440-720	Bi-D	M8	<nnnnnnnn>
		Print mode setting times	720-720	Bi-D	M9	<nnnnnnnn>
		Print mode setting times	720-360	Bi-D	M10	<nnnnnnnn>
		Print mode setting times	360-720	Bi-D	M11	<nnnnnnnn>
		Print mode setting times	Others	Bi-D	M12	<nnnnnnnn>
		Borderless print times	Sponge 1		M13	<nnnnnnnn>
		Borderless printing times	Sponge 2		M14	<nnnnnnnn>
		Borderless print times	Sponge 3		M15	<nnnnnnnn>
		Borderless print times	Sponge 4		M16	<nnnnnnnn>
		Borderless print times	Sponge 5		M17	<nnnnnnnn>
Borderless print times	Sponge 6		M18	<nnnnnnnn>		
Borderless print times	Sponge 7		M19	<nnnnnnnn>		
Borderless print times	Sponge 8		M20	<nnnnnnnn>		
Borderless print times	Sponge 9		M21	<nnnnnnnn>		
Borderless print times	Sponge 10		M22	<nnnnnnnn>		
Borderless print times	Sponge 11		M23	<nnnnnnnn>		
Borderless print times	Sponge 12		M24	<nnnnnnnn>		
Borderless print (four edges) Operation times (1 cut)				M25	<nnnnnnnn>	
Borderless print (four edges) Operation times (2 cuts)				M26	<nnnnnnnn>	

Table 1-48. Maintenance mode 2 setup items (continued)

Top menu (Panel display)	Item menu 1 (Panel display)	Item menu 2		Panel display	Setup value	
Maintenance information menu (MAINTINFO)	Panel setting (MENUO)	PC setting		O1	<nnnnnnnn>	
		Roll paper margin		O2	<nnnnnnnn>	
		Borderless print setting		O3	<nnnnnnnn>	
		Cutter position adjustment		O4	<nnnnnnnn>	
		Final cutter position adjustment		O5	<YY><MM><DD>	
		Nozzle check pattern print		O6	<nnnnnnnn>	
		Final nozzle check pattern print		O7	<YY><MM><DD>	
		Bi-D	BLACK	Adjustment times	O8	<nnnnnnnn>
		Bi-D	BLACK	Final adjustment date	O9	<YY><MM><DD>
		Bi-D	COLOR	Adjustment times	O10	<nnnnnnnn>
		Bi-D	COLOR	Final adjustment times/date	O11	<YY><MM><DD>
		Uni-D	Adjustment times		O12	<nnnnnnnn>
		Uni-D	Final adjustment date		O13	<YY><MM><DD>
		Cutting pressure		O14	<nnnnnnnn>	
		Cutting method		O15	<nnnnnnnn>	
		Paper feeding adjustment		O16	<nnnnnnnn>	
		Paper suction		O17	<nnnnnnnn>	
		Print adjustment		O18	<nnnnnnnn>	

Table 1-48. Maintenance mode 2 setup items (continued)

Top menu (Panel display)	Item menu 1 (Panel display)	Item menu 2	Panel display	Setup value
Maintenance information menu (MAINTINFO)	Fatal error (MENUF)	Service call history1 (Type)	F1	<xxxxxxx>
		Service call history1 (Date)	F2	<YY><MM><DD>
		Service call history2 (Type)	F3	<xxxxxxx>
		Service call history2 (Date)	F4	<YY><MM><DD>
		Service call history3 (Type)	F5	<xxxxxxx>
		Service call history3 (Date)	F6	<YY><MM><DD>
		Service call history4 (Type)	F7	<xxxxxxx>
		Service call history4 (Date)	F8	<YY><MM><DD>
		Service call history5 (Type)	F9	<xxxxxxx>
		Service call history5 (Date)	F10	<YY><MM><DD>
		Service call history6 (Type)	F11	<xxxxxxx>
		Service call history6 (Date)	F12	<YY><MM><DD>
		Service call history7 (Type)	F13	<xxxxxxx>
		Service call history7 (Date)	F14	<YY><MM><DD>
		Service call history8 (Type)	F15	<xxxxxxx>
		Service call history8 (Date)	F16	<YY><MM><DD>
		Service call history9 (Type)	F17	<xxxxxxx>
		Service call history9 (Date)	F18	<YY><MM><DD>
		Service call history10 (Type)	F19	<xxxxxxx>
		Service call history10 (Date)	F20	<YY><MM><DD>

Table 1-48. Maintenance mode 2 setup items (continued)

Top menu (Panel display)	Item menu 1 (Panel display)	Item menu 2	Panel display	Setup value
Maintenance information menu (MAINTINFO)	Normal error (MENUN)	Normal error history 1 (Type)	N1	<xx>
		Normal error history 1 (Date)	N2	<YY><MM><DD>
		Normal error history 2 (Type)	N3	<xx>
		Normal error history 2 (Date)	N4	<YY><MM><DD>
		Normal error history 3 (Type)	N5	<xx>
		Normal error history 3 (Date)	N6	<YY><MM><DD>
		Normal error history 4 (Type)	N7	<xx>
		Normal error history 4 (Date)	N8	<YY><MM><DD>
		Normal error history 5 (Type)	N9	<xx>
		Normal error history 5 (Date)	N10	<YY><MM><DD>
		Normal error history 6 (Type)	N11	<xx>
		Normal error history 6 (Date)	N12	<YY><MM><DD>
		Normal error history 7 (Type)	N13	<xx>
		Normal error history 7 (Date)	N14	<YY><MM><DD>
		Normal error history 8 (Type)	N15	<xx>
		Normal error history 8 (Date)	N16	<YY><MM><DD>
		Normal error history 9 (Type)	N17	<xx>
		Normal error history 9 (Date)	N18	<YY><MM><DD>
		Normal error history 10 (Type)	N19	<xx>
		Normal error history 1 (0Date)	N20	<YY><MM><DD>
	Error times (Roll paper width)	N21	<nnnnnnnn>	
	Error times (Sheet)	N22	<nnnnnnnn>	
Parts counter clear at replacement (MENUX)	Carriage unit clear at replacement	X1	EXEC	
	Cleaning unit clear at replacement	X2	EXEC	
	Head clear at replacement	X3	EXEC	
	Cutter solenoid clear at replacement	X4	EXEC	

Table 1-48. Maintenance mode 2 setup items (continued)

Top menu (Panel display)	Item menu 1 (Panel display)	Item menu 2	Panel display	Setup value
Maintenance information initializing menu (INITINFO)	Operation time, environment information counter clear (INIT.MENUE)	-	-	EXEC
	Carriage information counter clear (INIT.MENUR)	-	-	EXEC
	Ink system information clear (INIT.MENUS)	-	-	EXEC
	Head information counter clear (INIT.MENUH)	-	-	EXEC
	Cutter information counter clear (INIT.MENUC)	-	-	EXEC
	Ink information 1 counter clear (INIT.MENUA)	-	-	EXEC
	Ink information 2 counter clear (INIT.MENUB)	-	-	EXEC
	Paper information counter clear (INIT.MENUP)	-	-	EXEC
	Print mode information counter clear (INIT.MENUM)	-	-	EXEC
	Panel setting information counter clear (INIT.MENUO)	-	-	EXEC
	Fatal error information counter clear (INIT.MENUF)	-	-	EXEC
	Normal error information counter clear (INIT.MENUN)	-	-	EXEC

Note 1: The panel display is English that is common for Japanese / English / French / German / Spanish / Portuguese.

2: Roll paper widths XX are following,

Stylus Pro 7600: 610mm and over ~ 160mm and under is classified at 50mm intervals.

Stylus Pro 9600: 1018mm and over ~ 10mm and under is classified at 100mm intervals.

3: However, if the width of the installed paper is smaller than set width, the latter will be used.

INITIALIZE NVRAM, TIMER, LIFE COUNTER, MECHANICAL COUNTER

Selecting this mode allows the user to initialize the NVRAM, timer, life counter, and mechanical counter.

INITIALIZE NVRAM

Selecting this mode allows the user to initialize the NVRAM.

INITIALIZE RTC

Selecting this mode allows the user to set RTC initialized time to NVRAM. The panel display is following;

RTC INIT = <YY>/<MM>/<DD>/<HH>

NOTE: <YY>: year, <MM>: month, <DD>: day, <HH>: hour

The cursor shifts “year → month → day → hour → year...” with SelectType button. Time is adjusted with Paper Feed Δ∇ buttons. RTC initialized time is set to NVRAM with Enter button, and RTC is initialized.

NOTE: “RTC backup battery end” maintenance call is reset when RTC is initialized.

INITIALIZE CR MOTOR LIFE

Selecting this mode allows the user to initialize the CR motor life counter.

INITIALIZE CR MOTOR LIFE TOTAL

Selecting this mode allows the user to initialize the CR motor life total counter.

INITIALIZE PF MOTOR LIFE

Selecting this mode allows the user to initialize the PF motor life counter.

INITIALIZE HEAD UNIT LIFE

Selecting this mode allows the user to initialize the head unit life counter.

INITIALIZE CLEANING UNIT LIFE

Selecting this mode allows the user to initialize the cleaning unit life counter.

INITIALIZE TOTAL PRINTS

Selecting this mode allows the user to initialize the total printed page counter.

INITIALIZE INK CAPACITY

Selecting this mode allows the user to initialize the ink capacity counter.

NVRAM COUNTER VALUE INDICATION

Selecting this mode allows the user to indicate each life counter in decimal.

PARAMETER BACKUP

Selecting this mode allows the user to move to parameter backup mode. In parameter backup mode, NVRAM responses and changes to manufacture setting commands are possible with minimal chance of error. When an error occurs, NVRAM contents are acquired and can be analyzed.

MAINTENANCE INFORMATION MENU

Read information for printer maintenance.

MAINTENANCE INFORMATION INITIALIZING MENU

Initialize information for printer maintenance. (Counter clear)

PARAMETER BACKUP MODE MENU

When this mode is selected, you can execute NVRAM backup or writing.

This mode does not support any printing data. In case printing data is sent, normal operation is not guaranteed.

Only turning off the power works to terminate this mode. (Transition to any other menu is not allowed.)

1.4.6 Paper feeding adjustment conversion table

The adjustment conversion table has four 256byte screens in NVRAM. The details are as follows.

Table 1-49.

Table name	Description
1 Pigment user table	For pigment ink media, can be changed by user, 256byte
2 Dye user table	For dye inku media, can be changed by user 256byte
3 Pigment system table	For pigment ink media, cannot be changed by user, 256byte
4 Dye system table	For dye ink media, user cannot be changed by user, 256byte

Use during printing

■ User table

When the conversion mode is ON in the paper feeding adjustment conversion mode (SN 0A), the paper feeding adjustment setting (SN 04) m2 parameter will be media ID and indicate user table address. The value stored in this address is used as the paper feeding adjustment value. However, if the stored value is FFh, the table is divided into three parts as shown below. The m2 parameter of the paper feeding adjustment setting (SN 04) to be used as the paper feeding adjustment value changes depending on the corresponding ID value.

1. 01h ~ 40h Use the value of ID+50h as the paper feeding adjustment value.
2. 41h ~ C0h Use ID as the paper feeding adjustment value.
3. C1h ~ FFh Use the value of ID-64h as the paper feeding adjustment value.

NOTE: Designation of pigment/dye depends on ink type setting (NPD setting/IK).

■ System table

This table is not used during printing. The manufacture setting value is stored to use as backup for user table.

How to change correction values

■ User table

The user table can be changed from the SN menu of Maintenance mode 1. (See “1.4.4 Maintenance Mode 1 (p.66)” for details.)

It can be changed by registering the remote commands paper feeding adjustment offset value commands (SN83). It is necessary to save changes (SV).

■ System table

The system table can be changed from the Maintenance mode 2 adjustment menu. (See “1.4.5 Maintenance Mode 2 (p.70)” for details.)

User table initialization

■ Maintenance mode 1

Selecting “User table initialization” in SN menu allows the user to initialize Maintenance mode 1.

■ Remote commands

Setting m2=00h in paper feeding adjustment offset value registration (SN 83) allows the user to initialize remote commands.

1.4.7 Firmware Reload

1.4.7.1 Reload from ROM-DIMM

Reload method from ROM-DIMM is following;

1. Write RCC format F/W file into ROM-DIMM (C309type).
2. Switch power OFF and unplug the cable.
3. Remove the rear cover and insert “1.” ROM-DIMM into the exclusive slot.
4. Switch power ON.
5. Installation starts and finishes automatically.
6. Switch power OFF and unplug the cable.
7. Remove ROM-DIMM from exclusive slot.
8. Switch power ON.

1.4.7.2 Reload with F/W DOWNLOAD mode

Reload method via parallel interface is following;

1. Connect the printer to the host with a parallel cable.
2. Switch power ON pushing Enter + Paper Source + Cleaning buttons.
3. Check the printer panel displays “F/W DOWNLOAD”.
4. Send UPG format F/W file from the host.
5. Installation is completed.
6. Restart the printer (Power Off → Power On)

1.4.7.3 Installation with service utility (F/W Update function)

Installation via parallel interface is following;

1. Connect the printer to the host with a parallel cable.
2. Switch power ON.
3. Check that the printer panel displays “READY”.
4. Send UPG format F/W file from the host service utility.
5. Installation is completed.
6. The printer restarts automatically.

1.4.7.4 Compulsory start F/W DOWNLOAD mode

When F/W installation fails for some reasons and start up from begins the backup area, F/W DOWNLOAD mode is automatically selected. See above for more information about F/W DOWNLOAD mode.

NOTE: This mode is released when F/W installation is completed properly.

1.4.8 Function to prevent irregular printing

- Strong cancel data

When 16KB DC1 is sent to the head of each job, the printer performs a special initialization operation.

Refer to “[1.4.9 Initialization \(p.86\)](#)” for this initialization operation.

- Skip reading of irregular data
 - Unprintable characters
It doesn't print characters including ASCII code with text print mode.

Table 1-50. Unprintable hexadecimal code (Control character code)

Code	Character	Code	Character	Code	Character
00h	NULL	10h	DLE	7Fh	DEL
01h	SOH	11h	DC1	-	-
02h	STX	12h	DC2	-	-
03h	ETX	13h	DC3	-	-
04h	EOT	14h	DC4	-	-
05h	ENQ	15h	NAK	-	-
06h	ACK	16h	SYN	-	-
07h	BEL	17h	ETB	-	-
08h	BS	18h	CAN	-	-
09h	HT	19h	EM	-	-
0Ah	NL (LF)	1Ah	SUB	-	-
0Bh	VT	1Bh	ESC	-	-
0Ch	NP (FF)	1Ch	FS	-	-
0Dh	CR	1Dh	GS	-	-
0Eh	SO	1Eh	RS	-	-
0Fh	SI	1Fh	US	-	-

NOTE: 0Ah, 0Ch, 0Dh, 11h, and 1Bh are ESCP command supported by the printer. The printer judges the command and decides to print it.

- Job timeout
Refer to “[1.4.3.10 Job Timeout Setting \(p.42\)](#)”.

1.4.9 Initialization

There are three kinds of initialization method.

1.4.9.1 Hardware initialization

This printer is initialized when power to the printer is turned on.

- For initialization, printer operates as follows:
 - Initializes printer mechanism.
 - Clears input data buffer.
 - Clears print buffer.
 - Sets default values.

1.4.9.2 Software initialization

- The printer is initialized also by the ESC @ command.
 - For initialization, printer operates as follows:
 - Clears print buffer.
 - Sets default values.
- Cancel enhancement data(DC1×16kbyte) initializes the printer.
 - For initialization, printer operates as follows:
 - Clears print buffer.
 - Sets default values.
 - Immediately cut only when some printing remain on the paper.

1.4.9.3 Panel initialization

The printer is initialized when the Pause button is pressed for more than 3 seconds, or the printer recognizes the -INIT signal.

- For initialization, printer operates as follows:
 - Eject a paper. (If roll paper, it cuts paper skipping print part when Paper Source = Auto Cut, it doesn't cut when Paper Source = Cutter Off with SelecType)
 - Cap the print head.
 - Clears input data buffer.
 - Clears print buffer.
 - Sets default values.

1.4.10 Default Setup Values

1.4.10.1 Initial Setting for Operation

Default setup values are as follows. The parameters for items that may be saved for panel setup, default setup, and remote commands are used as default values.

- Page position: Current paper position as page start position
- Line feed: 1/6 inch
- Left margin
 - : Stylus Pro 7600 237th character
 - : Stylus Pro 9600 437th character
- Right margin: 1st character
- Character pitch: 10 cpi
- Print mode: Text mode
(non-raster graphics mode)

1.4.10.2 Ink Type Setting

In ink type setting during initial operation, dye ink will not be recognized if the switch No. 6 of the DIP Switches (SWD600) on the Main Board of the printer.

There may be a case where "Ink Type" is not set (NPD=0) by ink detection at power on (with the cartridges installed and without any other error). In such a case, check the position of the switch No. 6 of the DIP Switches.

NOTE: When the power is turned off without the cartridges installed, NPD=0 will be maintained.

- When switch No. 6 is OFF (dye prohibited)
 - When pigment has been installed
 - Sets "Ink Type" for the printer to "Pigment".
 - Initial charge is started if the initial charge flag has been set.
 - Every time the power is turned on after that, the printer will start as the Pigment machine.
 - When dye has been installed
 - Displays "INVALID CARTRIDGE".
(The LEDs for all colors flash even when dye for only one color has been installed.)
 - Does not set "Ink Type" for the printer. (NPD=0 is maintained)
 - NPD=0 even at the next start of the printer.
- When switch No. 6 is ON
 - Determines the ink type from the ink set that has been installed properly.
 - If the printer is currently used as the dye machine (NPD=2), the printer does not make judgment at power on. Therefore, the printer can be used as the dye machine the same way as before.
 - Even when "Ink Type" is changed to "Dye" directly in NPD mode, the printer can be used as the dye machine.

1.4.10.3 MW Printing Adjustment / Setting Values and Printing Modes

Table below indicates the relationship between the setting values by MW printing adjustment (setting on panel) and the printing mode numbers.

Table 1-51. MW Printing Adjustment / Setting Values and Printing Modes

No.	ESC(K)	n1	n2	ESC(D)	Setting on Panel								
					1	2	3	4	5	6	7	8	9
4	03h	-	-	360×360	No.4								
5	-	Non-MW/FOL	-	360×360	5			6	7	8			
6	-	MW	20h	360×360	5		6		7	8			
7	-	MW	-	360×360	5	6	7		8				
8	-	FOL	-	360×360	5	6	7	8					
9	-	Non-FOL	50h	360×720	9			10	11	12			
10	-	Non-FOL	-	360×720	9			10	11	12			
11	-	Non-FOL	B0h	360×720	9	10	11	12					
12	-	FOL	-	360×720	9	10	11	12					
13	-	Non-FOL2/MW2	-	720×360	13			14					
14	-	FOL2/MW2	-	720×360	13			14					
15	-	-	01h	720×720	15			16	17	18			
16	-	-	-	720×720	15		16		17	18			
17	-	-	66h	720×720	15	16	17		18				
18	-	-	68h	720×720	15	16	17	18					
19	-	Non-8PASS	-	1440×720	19			20					
20	-	8PASS	-	1440×720	19			20					
21	-	-	-	2880×720	21								
22	-	-	-	2880×1440	22								

Note : For printing modes (Nos.), see “1.4.10.4 Printing Mode Combination Table (p.89)”.

1.4.10.4 Printing Mode Combination Table

Valid print mode combination is following;

Table 1-52.

No.	ESC (K	ESC (i		ESC (D	ESC (e	Output resolution	Output dot size	Pass	Nozzle	Nozzle #	POL nozzle	Feeding	CR speed [CPS]	Notes
		n1	n2											
1	-	-	-	180×180	MD/ND/ND2/VSD1/VSD2	180×180	MD/ND/ND2/VSD1/VSD2	-	-	-	-	Specified by ESC(v command	240	DMW
2	-	-	-	360×180	MD/ND/ND2/VSD1/VSD2	360×180	MD/ND/ND2/VSD1/VSD2	-	-	-	-	Specified by ESC(v command	240	DMW
3	-	-	-	720×180	VSD4	720×180	VSD4	-	-	-	-	Specified by ESC(v command	190	DMW
4	03H	-	-	360×360	MD/ND/ND2/VSD1/VSD2	360×360	MD/ND/ND2/VSD1/VSD2	1	192	#1~#96	0	192/360"	240	Pseudo 4 color high-speed color mode
5	-	Non-MW/FOL	-	360×360	MD/ND/ND2/VSD1/VSD2	360×360	MD/ND/ND2/VSD1/VSD2	1	95	#1~#95	0	1-189/360"	240	Color skip supported
6	-	MW	20H	360×360	MD/ND/ND2/VSD1/VSD2	360×360	MD/ND/ND2/VSD1/VSD2	1	95	#1~#95	0	95/360"	240	
7	-	MW	-	360×360	MD/ND/ND2/VSD1/VSD2	360×360	MD/ND/ND2/VSD1/VSD2	1	96	#1~#96	35	61/360"	240	
8	-	FOL	-	360×360	MD/ND/ND2/VSD1/VSD2	360×360	MD/ND/ND2/VSD1/VSD2	2	96	#1~#96	22	37/360"	240	
9	-	Non-FOL	50H	360×720	MD/ND/ND2/VSD1/VSD2	360×720	MD/ND/ND2/VSD1/VSD2	1	96	#1~#96	21	75/720"	240	
10	-	Non-FOL	-	360×720	MD/ND/ND2/VSD1/VSD2	360×720	MD/ND/ND2/VSD1/VSD2	1	96	#1~#96	35	61/720"	240	
11	-	Non-FOL	B0H	360×720	MD/ND/ND2/VSD1/VSD2	360×720	MD/ND/ND2/VSD1/VSD2	1	96	#1~#96	43	53/720"	240	
12	-	FOL	-	360×720	MD/ND/ND2/VSD1/VSD2	360×720	MD/ND/ND2/VSD1/VSD2	2	96	#1~#96	14	41/720"	240	
13	-	Non-FOL2/MW2	-	720×360	MD/ND/ND2/VSD1/VSD2	720×360	MD/ND/ND2/VSD1/VSD2	2	96	#1~#96	22	37/360"	240	
14	-	FOL2/MW2	-	720×360	MD/ND/ND2/VSD1/VSD2	720×720	MD/ND/ND2/VSD1/VSD2	2	96	#1~#96	14	41/720"	240	V resolution conversion
15	-	-	01H	720×720	MD/ND/ND2/VSD1/VSD2	720×720	MD/ND/ND2/VSD1/VSD2	2	96	#1~#96	0	2-93/720"	240	Color skip supported
16	-	-	-	720×720	MD/ND/ND2/VSD1/VSD2	720×720	MD/ND/ND2/VSD1/VSD2	2	96	#1~#96	14	41/720"	240	
17	-	-	66H	720×720	MD/ND/ND2/VSD1/VSD2	720×720	MD/ND/ND2/VSD1/VSD2	2	96	#1~#96	26	35/720"	240	
18	-	-	68H	720×720	MD/ND/ND2/VSD1/VSD2	720×720	MD/ND/ND2/VSD1/VSD2	2	96	#1~#96	30	33/720"	240	
19	-	Except 8PASS	-	1440×720	MD/ND/ND2/VSD1/VSD2	1440×720	MD/ND/ND2/VSD1/VSD2	4	96	#1~#96	4	23/720"	240	
20	-	8PASS	-	1440×720	MD/ND/ND2/VSD1/VSD2	1440×720	MD/ND/ND2/VSD1/VSD2	8	96	#1~#96	8	11/720"	240	
21	-	-	-	-	-	-	-	-	-	-	-	-	-	-
22	-	-	-	2880×1440	VSD4	2880×1440	VSD4	4	92	#3~#94	0	23/1440"	190	

Note : When an improper combination is set, it prints with default of setting resolution (designated dot size).

1.5 Controller

- CPU: Hitachi SH7709S 100MHz
- Code ROM: External, 2MB
- Font ROM: None
- RAM:
 - Stylus Pro 7600: 32MB (Mounted RAM: IC4/6)
 - Stylus Pro 9600:64MB (Mounted RAM: IC4/6, IC600/604)
- Interface
 - IEEE 1284 interface
 - USB (HS, FS)
 - Type B interface

1.6 Interfaces

1.6.1 Parallel Interface

1.6.1.1 Compatibility Mode

SPECIFICATION

- Transmission mode: 8 bit parallel
- Synchronization: By STROBE pulse
- Handshaking: By BUSY and ACKNLG signal
- Signal level: TTL level (IEEE1284Level 1 device)
- Adaptable connector: 57-30360(amphenol) 36 pin or equivalent

NOTE: It is recommended to use as short an interface cable as possible.

CONNECTOR PIN ASSIGNMENT AND SIGNALS

For these signals, twist-pair wires are used, with the return side connected to the signal ground.

Table 1-53. Connector Pin Assignment and Signals (Compatibility)

Pin No.	Return GND pin	Signal Name	In/Out	Function
1	19	-STROBE	In	The strobe pulse. This signal is normally "HIGH" and read-in of data is executed after turning "LOW". The pulse width required at the receive end is 0.5 μs or more.
2	20	DATA0	In	The DATA0 through DATA7 signals represent data bits 0 to 7, respectively. Each signal is at high level when data is logical 1 and low level when data is logical 0.
3	21	DATA1	In	
4	22	DATA2	In	
5	23	DATA3	In	
6	24	DATA4	In	
7	25	DATA5	In	
8	26	DATA6	In	
9	27	DATA7	In	

Table 1-53. Connector Pin Assignment and Signals (Compatibility) (continued)

Pin No.	Return GND pin	Signal Name	In/Out	Function
10	28	-ACKNLG	Out	This signal, when the signal level is "LOW", indicates that the printer has received data and is ready to accept the next data. The pulse width is 1 μs or 3 μs. (See Figure 1-19)
11	29	BUSY	Out	This signal, when the level is "HIGH", indicates that the printer can not receive data. When the level is "LOW", the signal indicates that the printer can accept data. This signal turns "HIGH" in one of the following cases: <ul style="list-style-type: none"> <input type="checkbox"/> During data entry <input type="checkbox"/> In error status
12	28	PE	Out	This signal, when the level is "HIGH", indicates paper-out error. (Valid when ERROR = "LOW")
13	28	SLCT	Out	Always at "HIGH" level when the power to the printer is on. Pulled up to +5 V via 1.0 kΩ.
14	30	-AFXT	In	Not used
31	30	-INIT	In	The printer is initialized by input of a "LOW" pulse whose width is 50 μs or more.
32	29	-ERROR	Out	The "LOW" signal indicates that the printer is in error status.
36	30	-SLIN	In	Not used
18	--	Logic H	Out	Always at "HIGH" level. Pulled up to +5 V via 3.9 kΩ.
35	--	+5V	Out	Always at "HIGH" level. Pulled up to +5 V via 1.0 kΩ.
17	--	Chassis GND	-	Chassis GND.
16,33 19-30	--	GND	-	Signal GND.
15,34	--	NC	-	Not used

Note 1: "-" is prefixed to each signal which is active at "LOW" level.

- 2: In/Out refers to the direction of signal flow from the printer's point of view.
- 3: The "return side" means twist-pair return, which is connected to the signal GND. For interface, each signal is connected with a twist-pair wire and the return side is also connected. For protection against noise, this cable is shielded and connected to the chassis GND for each of the center machine and the printer.
- 4: All the interface conditions are based on the TTL level standard. Each of the rise time and fall time is 0.2 μs or less.
- 5: See [Figure 1-19](#) for details of signal timing.

- 6: Do not perform data transfer by ignoring the -ACKNLG signal or BUSY signal. (Data transfer to this printer must be executed by checking the level of the -ACKNLG signal or when the BUSY signal is "LOW".)
- 7: Assign appropriate character codes to DATA0 ~ 7 of the interface connector ("1" for open to GND and "0" for short to GND) and connect the BUSY signal line and the -STROBE signal line. Then without using any external equipment, you can conduct printing test of the printer including the interface circuit

PARALLEL INTERFACE TIMING CHART

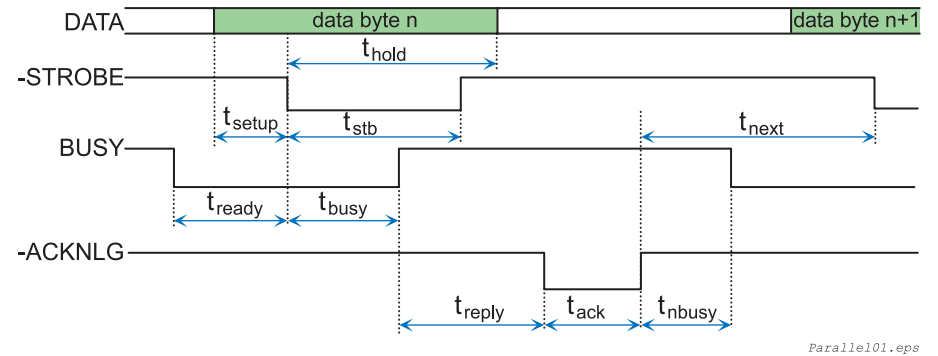

Parallel01.eps

Figure 1-19. Timing Chart

Table 1-54.

Parameter	Minimum	Maximum
tsetup	500 ns	-
thold	500 ns	-
tstb	500 ns	-
tready	0	-
tbusy	-	500 ns
tt-out*1	-	120 ns
tt-in*2	-	200 ns
treply	0	-
tacks	Typical 2us	
tnbusy	0	-
tnext	0	-

Note *1: Rise and fall time of every output signals

*2: Rise and fall time of every input signals

1.6.1.2 Nibble Mode

SPECIFICATION

- Transmission mode: 8 bit parallel
- Synchronization: By STROBE pulse
- Handshaking: By BUSY and ACKNLG signal
- Signal level: TTL compatible (IEEE1284Level 1 device)
- Data trans. timing: Refer to the IEEE-1284 specification
- Extensibility Request:
 The printer responds affirmatively when the extensibility request values are 00H or 04H, that mean,
 - 00H Request Nibble Mode Reverse Channel Transfer.
 - 04H Request Device ID; Return Data Using Nibble Mode Rev Channel Transfer.
- Device ID:
 - When IEEE1284.4 is valid
 - <xx><xx>
(Character strings, depending on <Model Name>)
 - MFG: EPSON;
 - CMD: ESCPL2,BDC,D4;
 - MDL: <Stylus Pro 7600-DYE/Stylus Pro 9600-DYE>;
 - CLS: PRINTER;
 - DES: EPSON<SP><Stylus Pro 7600-DYE/Stylus Pro 9600-DYE>;(<SP>:space)
 - When IEEE1284.4 is not valid
 - <xx><xx>
(Character strings, depending on <Model Name>)
 - MFG: EPSON;
 - CMD: ESCPL2,BDC;
 - MDL: <Stylus Pro 7600-DYE/Stylus Pro 9600-DYE>;
 - CLS: PRINTER;
 - DES: EPSON<SP>T<Stylus Pro 7600-DYE/Stylus Pro 9600-DYE>; (<SP>:space)

CONNECTOR PIN ASSIGNMENT AND SIGNALS

Table 1-55. Connector Pin Assignment and Signals (Nibble)

Pin No.	Return GND Pin	Signal Name	In/Out *	Function
1	19	HostClk	In	Host clock signal.
2	20	DATA0	In	The DATA0 through DATA7 signals represent data bits 0 to 7, respectively. Each signal is at high level when data is logical 1 and low level when data is logical 0.
3	21	DATA1	In	
4	22	DATA2	In	
5	23	DATA3	In	
6	24	DATA4	In	
7	25	DATA5	In	
8	26	DATA6	In	
9	27	DATA7	In	
10	28	PtrClk	Out	Printer clock signal.
11	29	PtrBusy /DataBit-3,7	Out	Printer busy signal and reverse channel transfer data bit 3 or 7.
12	28	AckDataReq /DataBit-2,6	Out	Acknowledge data request signal and reverse channel transfer data bit 2 or 6.
13	28	Xflag /DataBit-1,5	Out	X-flag signal and reverse channel transfer data bit 1 or 5.
14	30	HostBusy	In	Host busy signal.
31	30	-INIT	In	Not used.
32	29	-DataAvail /DataBit-0,4	Out	Data available signal and reverse channel transfer data bit 0 or 4.
36	30	1284-Active	In	1284 active signal.
18	--	Logic H	Out	Always "HIGH". Pulled up to +5 V via 3.9 K ohm resistor.
35	--	+5V	Out	Always "HIGH". Pulled up to +5 V via 1.0 K ohm resistor.
17	--	Chassis GND	--	Chassis GND.
16,33, 19-30	--	GND	--	Signal GND.
15,34	--	NC	--	Not used

Note "*": In/Out refers to the direction of signal flow from the printer's point of view.

1.6.1.3 ECP Mode

SPECIFICATION

- Transmission mode: IEEE-1284ECP mode
- Synchronization: IEEE-1284 specification
- Handshaking: IEEE-1284 specification
- Signal level: TTL compatible (IEEE1284Level 1 device)
- Data trans. timing: IEEE-1284 specification
- Extensibility Request:
The printer responds affirmatively when the extensibility request values are 10H or 04H, that mean,
 - 10H Request ECP Mode Reverse Channel Transfer.
 - 14H Request Device ID; Return Data Using ECP Mode Rev Channel Transfer.
- Device ID:
 - When IEEE1284.4 is valid
 - <xx><xx>
(Character strings, depending on <Model Name>)
 - MFG: EPSON;
 - CMD: ESCPL2,BDC,D4;
 - MDL: <Stylus Pro 7600-DYE/Stylus Pro 9600-DYE> ;
 - CLS: PRINTER;
 - DES: EPSON<SP>T<Stylus Pro 7600-DYE/Stylus Pro 9600-DYE>;(<SP>: space)
 - When IEEE1284.4 is not valid
 - <xx><xx>
(Character strings, depending on <Model Name>)
 - MFG: EPSON;
 - CMD: ESCPL2,BDC;
 - MDL: <Stylus Pro 7600-DYE/Stylus Pro 9600-DYE>;
 - CLS: PRINTER;
 - DES: EPSON<SP>T<Stylus Pro 7600-DYE/Stylus Pro 9600-DYE>; (<SP>: space)

CONNECTOR PIN ASSIGNMENT AND SIGNALS

Table 1-56. Connector Pin Assignment and Signals (ECP)

Pin No.	Return GND Pin	Signal Name	In/Out*	Function
1	19	HostClk	In	Data or address information are transferred from a host to a printer.
2	20	DATA0	In	The DATA0 through DATA7 signals represent data bits 0 to 7, respectively. Each signal is at high level when data is logical 1 and low level when data is logical 0.
3	21	DATA1	In	
4	22	DATA2	In	
5	23	DATA3	In	
6	24	DATA4	In	
7	25	DATA5	In	
8	26	DATA6	In	
9	27	DATA7	In	
10	28	PeriphClk	Out	Data is transferred from a printer to a host.
11	29	PeriphAck	Out	A printer uses this signal for a flow control of forward direction. Also this signal offers the data bit 9 that use it to judge whether or not it is information command information or data to be output on the data signal of reverse direction.
12	28	nAckReverse	Out	A printer does drive to Low and approve nReverseRequest.
13	28	Xflag	Out	X-flag signal and reverse channel transfer data bit 1 or 5.
14	30	HostAck	In	A host uses this signal for a flow control of reverse direction. Also this signal offers the data bit 9 that use it to judge whether or not it is information command information or data to be output on the data signal of forward direction.
31	30	nReverseRequest	In	This signal is made a low, to change a channel toward reverse.
32	29	nPeriphReques	Out	This signal uses to produce a host interrupt.
36	30	1284-Active	In	1284 active signal. "HIGH" in ECP mode
18	--	PeriphLogic	Out	Always "HIGH". Pulled up to +5 V via 3.9 K ohm resistor.
35	--	+5V	Out	Always "HIGH". Pulled up to +5 V via 1.0 K ohm resistor.
17	--	Chassis GND	--	Chassis GND.
16,33 19-30	--	GND	--	Signal GND.
15,34	--	NC	--	Not connected.

Note "*": In/Out refers to the direction of signal flow from the printer's point of view.

1.6.2 USB interface

SPECIFICATION

- Standard: “Universal Serial Bus Specifications Revision 2.0”
“Universal Serial Bus Specifications Revision 1.1”
“Universal Serial Bus Devices Class Definition for Printing Devices Version 1.1”
- Bit rate: 480Mbps (High Speed Mode)
12Mbps (Full Speed Device)
- Data format: NRZI
- Adaptable connector: USB Series B
- Acceptable cable length: 2m
- Device ID:
 - When IEEE1284.4 is valid
 - <xx><xx>
(Character strings, depending on <Model Name>)
 - MFG : EPSON;
 - CMD : ESCPL2,BDC,D4;
 - MDL : <Stylus Pro 7600-DYE/Stylus Pro 9600-DYE>;
 - CLS : PRINTER;
 - DES : EPSON<SP>T<Stylus Pro 7600-DYE/Stylus Pro 9600-DYE>;(<SP>: space)
 - When IEEE1284.4 is not valid
 - <xx><xx>
(Character strings, depending on <Model Name>)
 - MFG : EPSON;
 - CMD : ESCPL2,BDC;
 - MDL : <Stylus Pro 7600-DYE/Stylus Pro 9600-DYE>;
 - CLS : PRINTER;
 - DES : EPSON<SP>T<ModeStylus Pro 7600-DYE/Stylus Pro 9600-DYE>;(<SP>: space)

CONNECTOR PIN ASSIGNMENT AND SIGNALS

Table 1-57. Connector Pin Assignment and Signals (USB(FS))

Pin No	Signal name	In/Out	Function description
1	VCC	-	Cable power. Maximum power consumption is 100mA
2	-Data	bi-directional	data
3	+Data	bi-directional	data, pull up to +3.3V via 1.5K ohm resistor
4	Ground	-	Cable ground

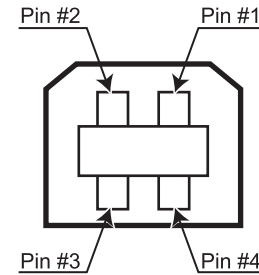

USB_IF.eps

Figure 1-20. Pin Assignment

1.6.3 Optional Interface

Type-B interface (level 2, 1200mA type) is supported.

REPLY MESSAGE

(Case of using Type-B I/F card except above)

- Card in Type-B slot 1:
Main-Type
 - Stylus Pro 7600:
MT48p,PW240c110cpi,PRG(BNxxxx)rev,AP800ma,SPD0fast,GDI
 - Stylus Pro 9600:
MT48p,PW440c110cpi,PRG(BWxxxx)rev,AP800ma,SPD0fast,GDI

NOTE: xxxx is F/W version.

- Product-Name: <Stylus Pro 7600-DYE/Stylus Pro 9600-DYE>
- Emulation-Type : ESCPL2-00
- Entity-Type : EPSONLQ2

REPLY FOR OPTION COMMAND

Table 1-58. Reply List

Option command number	Command name	Reply-A	Reply-B
00h	No-operation	Accept	None
01h	Start Hardware Reset	Accept	Execute OK
02h	Start Software Reset	Reject	
03h	Send Main System Type	Accept	
04h	Send Name Data	Reject	
05h	Inquire Name Data	Accept	
06h	Send Product Name	Accept	
07h	Send Software Emulation Type	Accept	
08h	Complete Buffered Data	Accept	Check Condition
09h	Stop Procedure	Reject	Execute OK
0Ah	Return Buffered Data	Reject	
0Bh	Send Entity Type	Accept	
0Ch	Send Status	Accept	
0Dh	Quit Procedure	Reject	
0Eh	Inquire ASCII Message	Reject	None
0Fh	Send ASCII Message	Accept	
10h-13h		Unknown	None
14h	Inquire Emergency Message	Accept	Execute OK
15h	Send Emergency Reply	Accept	
16h-1Fh		Unknown	None
20h-FFh		Reserved	None

SUPPORTED MAIN COMMAND AND SENDING TIMING

Table 1-59. Commands and Sending Timing

Main command number	Command name	Sending timing
01h	Start Software Reset	-Init signal on the std. parallel -Type B I/F Option command: 01h -Panel Reset -Cold start
04h	Send Name Data	-Type B I/F Option command: 05h
07h	Inquire Software Emulation Type	-Changing Software Emulation type
0Eh	Inquire ASCII Message	-Writing to DBIN-register
14h	Inquire Emergency Reply	-Reply for Emergency command
15h	Send Emergency Message	-Receive Emergency command

Sending BDC-ST through DBIN register

When State-Reply is set "ON" by ST from Type-B I/F, sending BDC-ST through DBIN register is started. When State-Reply is started, "Start" and "End" of BDC-ST characters are announced by sending the Main command 0Eh.

- Emergency command (BGJC):
 - "0x00": Get device ID
 - "0x01": Get all status
 - "0x08": LFP Bi-D command (For acquisition of job information)

1.6.4 Supplements

PREVENTION HOSTS FROM DATA TRANSFER TIME-OUT

When data is received from the parallel interface or the type B interface while no error has occurred (including the pause condition), the printer receives data a rate of 2 byte/second while buffer free space is less than 16 kbytes in order to prevent host timeout. When buffer free space is more than 32kbytes, the 2 byte/second receive rate is cleared, and receive is halted when free space reaches 16 bytes, and returns to the 2 byte/second rate when free space reaches 512 kbyte or more.

INTERFACE SELECTION

The printer has the parallel interface, the USB interface, the optional interface. These interfaces are selected manually by the default setting mode or selected automatically.

- Manual selection
 - One of 3 interfaces can be selected; the parallel interface, the USB interface, the optional interface.
- Automatic selection
 - Select a interface which the printer received data first after power ON. If it passes 10 seconds after interruption of data receiving, it will be idle status (any interface is not selected) and will select a interface which the printer received data first.
- Interface state and interface selection
 - When the parallel interface is not selected, the interface goes into the busy status.
Only reverse communication can be done at this time.
 - When the printer is initialized or returned to the idle state, the parallel interface becomes ready status, the USB interface becomes non NACK reply status, and the option interface resets OFF-LINE bit of Main Status Register (MNSTS).
 - INIT signal on the parallel interface is not effective while that interface is not selected or nibble Mode , ECP Mode.

1.7 Optional Units and Consumables

1.7.1 Ink Cartridge

Selection of ink types, detection of cartridges and the amount of remaining ink are controlled by CSIC.



- When installing the pigment ink cartridges, shake them gently a couple of times beforehand to ensure the designed print quality.
- The 220 ml ink cartridges are supported only by Stylus Pro 9600.

SPECIFICATION

- Type: Pigment / Dye ink cartridge
- Form: Exclusive ink cartridge
- Ink capacity:
 - 110ml (Model Number: ICxx24)
 - 220ml (Stylus Pro 9600 only) (Model Number: ICxx25)
- Dimension:
 - 110ml: 25.1 mm (W) × 165.8 mm (D) × 105.3 mm (H)
 - 220ml: 25.1 mm (W) × 280.8 mm (D) × 105.3 mm (H)
- Total weight:
 - 110ml: approx. 200g
 - 220ml: approx. 385g
- Effective ink:
 - 110ml: more than 97.0 g
 - 220ml: more than 205.0 g
- Color:
 - Photo Black, magenta, light magenta, cyan, light cyan, yellow Light Black (pigment only), Matte black (pigment only)
- Environment condition
 - Temperature: 10°C ~ 40°C
 - Relative humidity: 5% ~ 85%

- Storage temperature

Condition	temperature	Remarks
Packed	-30°C ~ 40°C	Within 1 month when 40°C
Installed	-20°C ~ 40°C	Within 1 month when 40°C
Packed transportation	-30°C ~ 60°C	Within 1 month when 40°C Within 120 hours when 0°C



If you remove an ink cartridge before it reaches the ink end state, you should store it under the same ambient conditions as for the printer body in such a way that the ink discharge opening is protected from dust intrusion. The ink cartridge stored as such and installed again can be used if it is within the term of availability.

- Ink life: 2 years from production date
- Print quality assured: pigment:
6 months after open / dye: 2 years from production date

INSTALLATION LOCATIONS

The locations to install the ink cartridges are assigned from the left side of the ink cartridge holder as indicated below:

Table 1-60. Locations to Install Ink Cartridges

	Dye	Pigment 1	Pigment 2	Pigment 3
1	K	Photo K	Matte K	Matte K
2	K	Lk	Lk	Matte K
3	C	C	C	C
4	M	M	M	M
5	LC	LC	LC	LC
6	LM	LM	LM	LM
7	Y	Y	Y	Y



Any ink cartridge other than the K and LK ink cartridges is equipped with a wrong insertion preventing mechanism so that it can be installed only at its position and in the correct orientation.

1.7.2 Cleaning cartridge



The cleaning cartridge is the same as the 220-ml ink cartridge in shape except that it does not have the projection for a color block.

- Type: Exclusive cleaning cartridge
- Dimension: Same as 220ml exclusive ink cartridge
- Capacity: Same as 220ml exclusive ink cartridge
- Total weight: Same as 220ml exclusive ink cartridge
- Effective cleaning solution: Same as 220ml exclusive ink cartridge
- Environment condition: Same as 220ml exclusive ink cartridge
- Storage temperature: Same as 220ml exclusive ink cartridge
- Life: Same as 220ml exclusive ink cartridge

1.7.3 Draining cartridge



The draining cartridge is the same as the 110-ml ink cartridge in shape except that it does not have the projection for a color block.

- Type: Exclusive draining cartridge (no ink pack)
- Dimension: Same as 110ml exclusive ink cartridge
- Capacity: None
- Total weight: 75g approx.
- Effective cleaning solution: None
- Environment condition: Same as 110ml exclusive ink cartridge
- Storage temperature: Same as 110ml exclusive ink cartridge
- Life: Same as 110ml exclusive ink cartridge

1.7.4 Maintenance Tank

The maintenance tank is located in the lower space at the right side of the printer body and constructed in such a way that the user can replace it when “maintenance tank full” is detected.

- Type: Exclusive maintenance tank for waste ink
- Dimension: Width: 102.5 mm × Depth: 235 mm × Height: 79.5 mm
- Capacity: 1000ml approx.
- Total weight: TBD
- Waste ink permitted limit: 650ml
- Environment condition: TBD

CHAPTER

2

OPERATING PRINCIPLES

2.1 Overview

This chapter explains the print mechanism and operating principles for the EPSON Stylus Pro 7600/9600.

The explanation is composed as follows:

- 2.2 Print Mechanism Components (*p.102*)
 - 2.2.1 Carriage (CR) Mechanism (*p.103*)
 - 2.2.2 Paper Feed Assembly (*p.113*)
 - 2.2.3 Cleaning Mechanism (*p.115*)
 - 2.2.4 Ink Supply Mechanism (*p.117*)
 - 2.2.5 Others (*p.118*)
- 2.3 Outline of Control Circuit Board (*p.119*)
- 2.4 Outline of Power Supply Circuit Board (*p.120*)

2.2 Print Mechanism Components

The major electrical parts used in the printer mechanism of this printer are as shown below. Hereafter, we will explain each printer mechanism focusing on these parts.

Table 2-1. Printer Mechanism Components

Part	Drive voltage	Description	Refer to
Carriage (CR) Mechanism (p.103)			
Print head		The number of nozzles: 96 Nozzle x 7 colors	p.105
Head thermistor	+3.3V	Incorporated in the print head	
CR motor	+42V	DC motor	p.104
CR_HP sensor (Carriage origin)	+3.3V	Transmission type photo-interrupter	p.104
CR encoder sensor	+5V	Linear encoder (180LPI)	p.104
Pump motor	+42V	DC motor	p.115
HD_SLID sensor (Head slide origin)	+3.3V	Reflection type photo-interrupter	p.107
P_EDGE sensor (Paper edge)	+5V	Reflection type photo-interrupter	p.108
Cutter solenoid	+24V	DC solenoid	p.112
Paper Feed Assembly (p.113)			
PF motor	+42V	DC motor	p.113
PF encoder sensor	+5V	Linear encoder (360LPI)	p.113
Paper suction fans	+24V	The number of DC blowers Stylus Pro 7600: 2 Stylus Pro 9600: 3	p.114
P_REAR sensor (Paper rear)	+5V	Reflection type photo-interrupter	p.114
P_THICK_0.3 sensor (Paper thickness)	+3.3V/ +5V	Transmission type photo-interrupter	p.114
P_THICK sensor (Paper thickness)	+5V	Transmission type photo-interrupter	p.114
Release Sensor (I/H lever)	+5V	Limit switch	p.114
Ink Supply Mechanism (p.117)			
Pump motor	+42V	DC motor	p.115
Cleaning Mechanism (p.115)			

Table 2-1. Printer Mechanism Components (continued)

Part	Drive voltage	Description	Refer to
Ink ID	+5V, +3.3V	CSIC	p.117
Maintenance tank	+5V, +3.3V	CSIC	p.115
Others (p.118)			
Cover open sensor (Cover Open L)	+3.3V	Limit switch	p.118
MAIN board		Printer control/drive circuit board	p.119
Radiator cooling fan	+5V	DC brushless fan	
Dip switch	–	Dip switch	p.207
Jumper	–	Jumper	
Power supply board	–		p.120

2.2.1 Carriage (CR) Mechanism

Stylus Pro 7600/9600 is equipped with a unique carriage mechanism which enables reliable, high-precision movement of the on-carriage head for high-precision printing in the printing range (= carriage movement range).

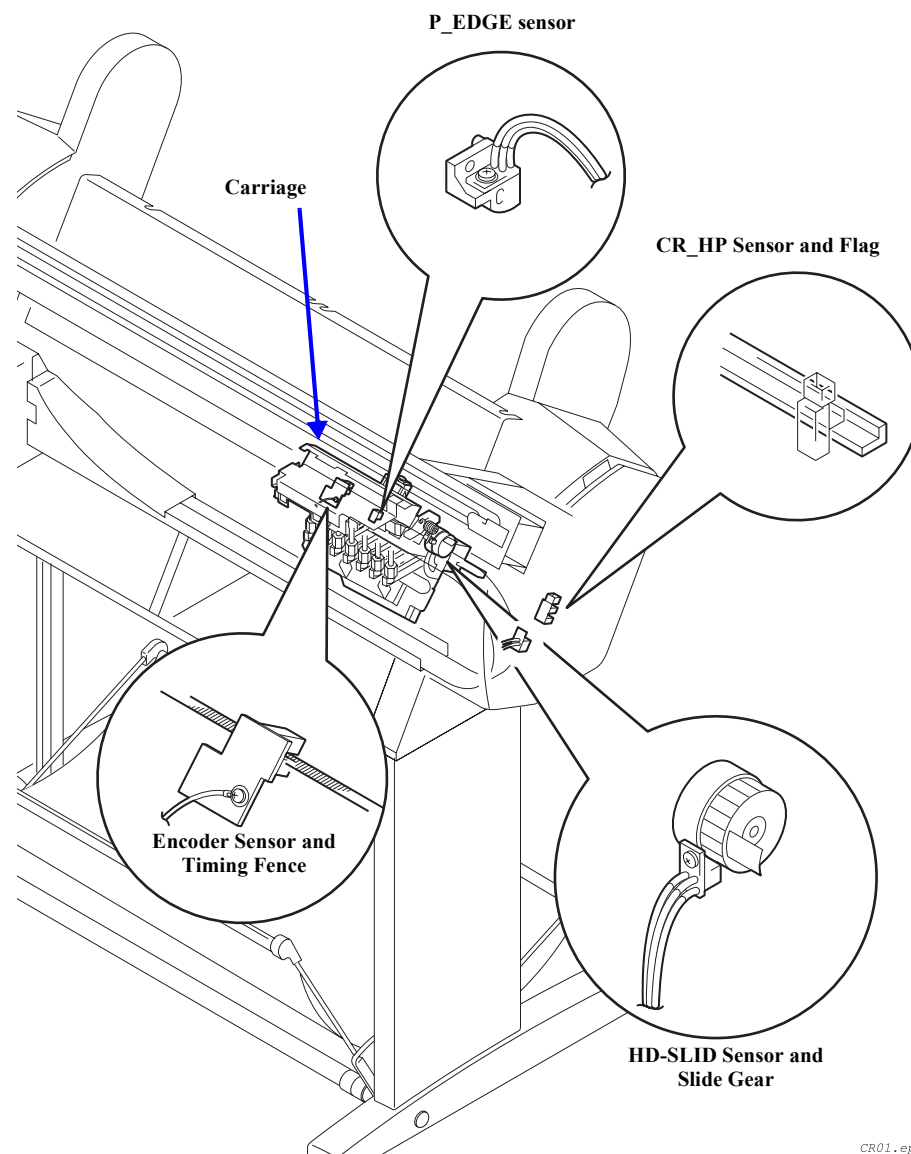

Figure 2-1. Carriage Mechanism

CARRIAGE MOVING UNIT

In place of the carriage holding system in which 2 CR guide shafts extending in the column direction were used, as in the conventional models, a structure with the carriage mounted via multiple rollers (bearings) on a CR guide rail made of a square extruded aluminum pipe is used. Steel rails are incorporated in the roller contact and running surface, and the result is a reduction in friction in the direction of movement, reduced vibration and improved durability.

CAUTION



The screws used to fasten the CR guide rail should not be taken out and the carriage should not be removed. These are adjusted and assembled to the nearest 1/100 mm at the factory.

□ CR motor

A DC motor is used for the CR motor and the slit in the timing fence affixed on the bottom of and parallel with the CR guide rail is read by the encoder sensor mounted on the carriage (linear encoder system), and this signal is compared to logical control values in the control circuit on the MAIN board, which carries out feedback speed control. Through this control, high print precision is maintained.

Drive transmissions from the CR motor to the carriage use the easy-to-maintain, durable timing belt.

The sensors used in the carriage moving unit are described below.

□ CR_HP Sensor (Carriage Home Position)

This is a transmissive photosensor which is mounted on the right end of the printer mechanism and detects the entry position of the flag (projection) provided on the carriage as the carriage moving home position. Outputs from this sensor are “OFF” in the HP range and “ON” outside the HP range.

□ CR encoder sensor (Linear Encoder)

This encoder is mounted on the back of the carriage and outputs pulses (2 channels) corresponding to the position of the slit on the timing fence that is incorporated into the CR guide rail which are used for CR motor servo control and PTS (Print Timing Signal) generation. The resolution is 1/180 inch.

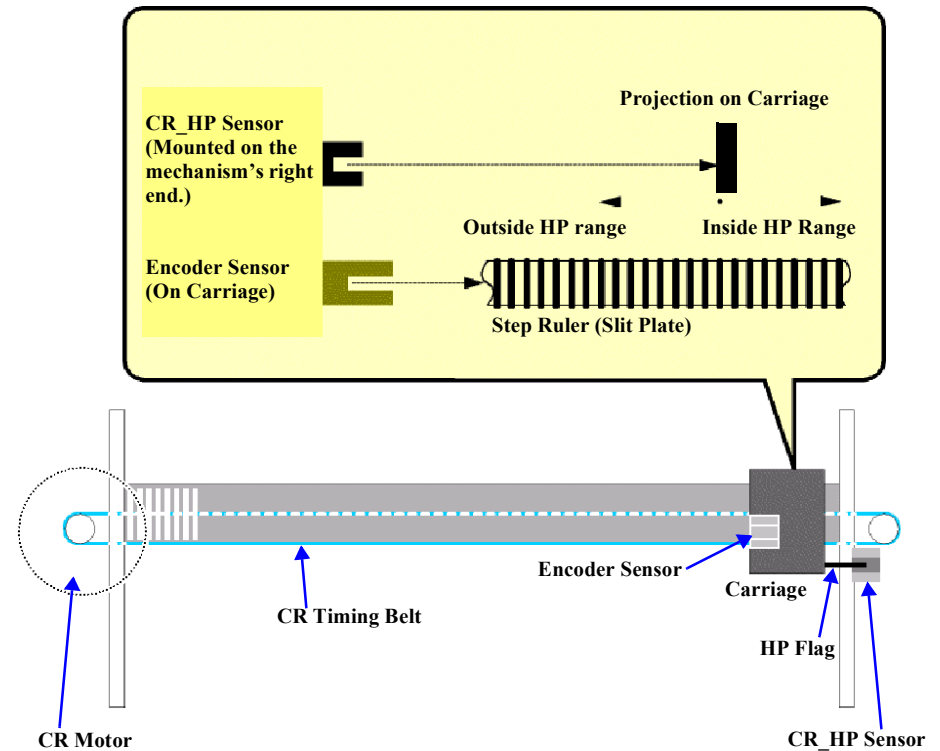

Figure 2-2. Carriage Mechanism Unit, Carriage Moving Unit

PRINT HEAD

Stylus Pro 7600/9600 employs a single print head which incorporates both functions for black and color. (The preceding model has two print heads, namely, head B and head C.)

The print head incorporates a thermistor. According to the temperature around the head detected by the thermistor, the CPU on the Main Board controls the ink discharge speed and the amount of ink to be discharged.

- Printing method: On-demand ink-jet
- Nozzle configuration: 96 nozzles x 7 rows = 672 nozzles
(See Figure 2-3 for nozzle arrangement.)
 - Black: 192 nozzles (96 nozzles for each of Black1 and Black2)
 - Color: 480 nozzles (96 nozzles for each of cyan, magenta, light cyan, light magenta and yellow)
 - Nozzle pitch: 0.141mm (1/180 inch) for each color

Table 2-2. Relationship between Nozzle Rows and Colors

Ink Type	Nozzle Row	Color
Pigment	A	Photo Black or Matte Black
	B	Gray or Matte Black
	C	C
	D	Lc
	E	M
	F	Lm
	G	Y
Dye	A	Bk
	B	Bk
	C	C
	D	Lc
	E	M
	F	Lm
	G	Y

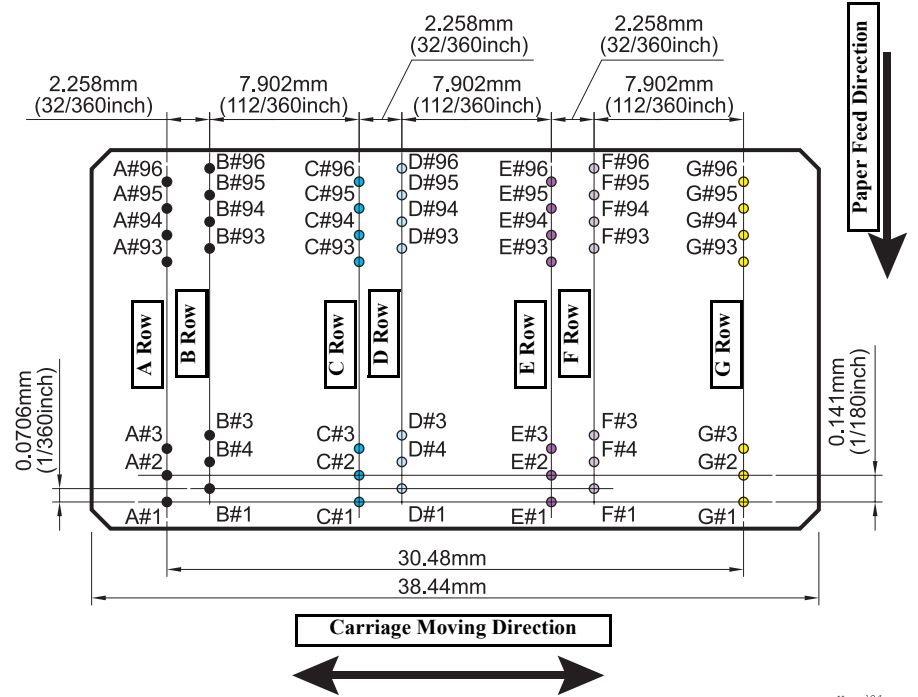

Figure 2-3. Nozzle Arrangement

- Drive waveform: There are three printing modes (drive waveforms) for each of use of pigment ink and use of dye ink.

Table 2-3. Printing Modes (Drive Waveforms)

Ink Type	Waveform Name	Ink Discharged (ng)	Drive Frequency	Print Resolution	CR Speed
Pigment ink	VSD1	13.8-27.6-41.5	8.64 KHz	H360 x V360 H720 x V360	240 CPS
	VSD2	4.5-9.5-23.0	8.64 KHz	H720 x V720 H1440 x V720	240 CPS
	VSD4	4.5	2 shots at 6.84 KHz	H2880 x V1440	190 CPS

Table 2-3. Printing Modes (Drive Waveforms)

Ink Type	Waveform Name	Ink Discharged (ng)	Drive Frequency	Print Resolution	CR Speed
Dye ink	VSD1-Dye	13.8-27.6-41.5	8.64 KHz	H360 x V360 H720 x V360	240 CPS
	VSD2-Dye	5.4-9.5-23.0	8.64 KHz	H720 x V720 H1440 x V720	240 CPS
	VSD4-Dye	2.5	2 shots at 6.84 KHz	H2880 x V1440	190 CPS

PLATEN GAP ADJUSTMENT UNIT

In order to maintain the print precision, it is necessary to maintain the carriage (= head) mounting position so that it is always a constant distance from the surface of the paper.

In this printer, the print head nozzle surfaces and platen surface are variable mechanisms so that the gap between the paper printing surface and the head nozzle surface can be kept constant.

The carriage has a 2-body construction with a sub-carriage on which the print heads are mounted attached to the carriage which forms the base. The sub-carriage moves in the vertical direction with respect to the paper surface. This movable system uses a cam. The sub-carriage to paper surface distance changes linearly from the cam (= PG) home position. When the carriage is in the HP position (= right end), the pump motor and the gear mounted on the cam shaft engage, the motor's rotation (reverse) drives the cam and the sub-carriage is positioned at the proper gap position.

In order to maintain the distance between the print head nozzle surface and the paper properly, the thicknesses of the paper used are classified into 3 levels for PG setting, namely, PG small (1.3 mm), PG medium (2.2 mm) and PG large (2.7 mm).

The sensors used in the platen gap adjustment unit are explained below.

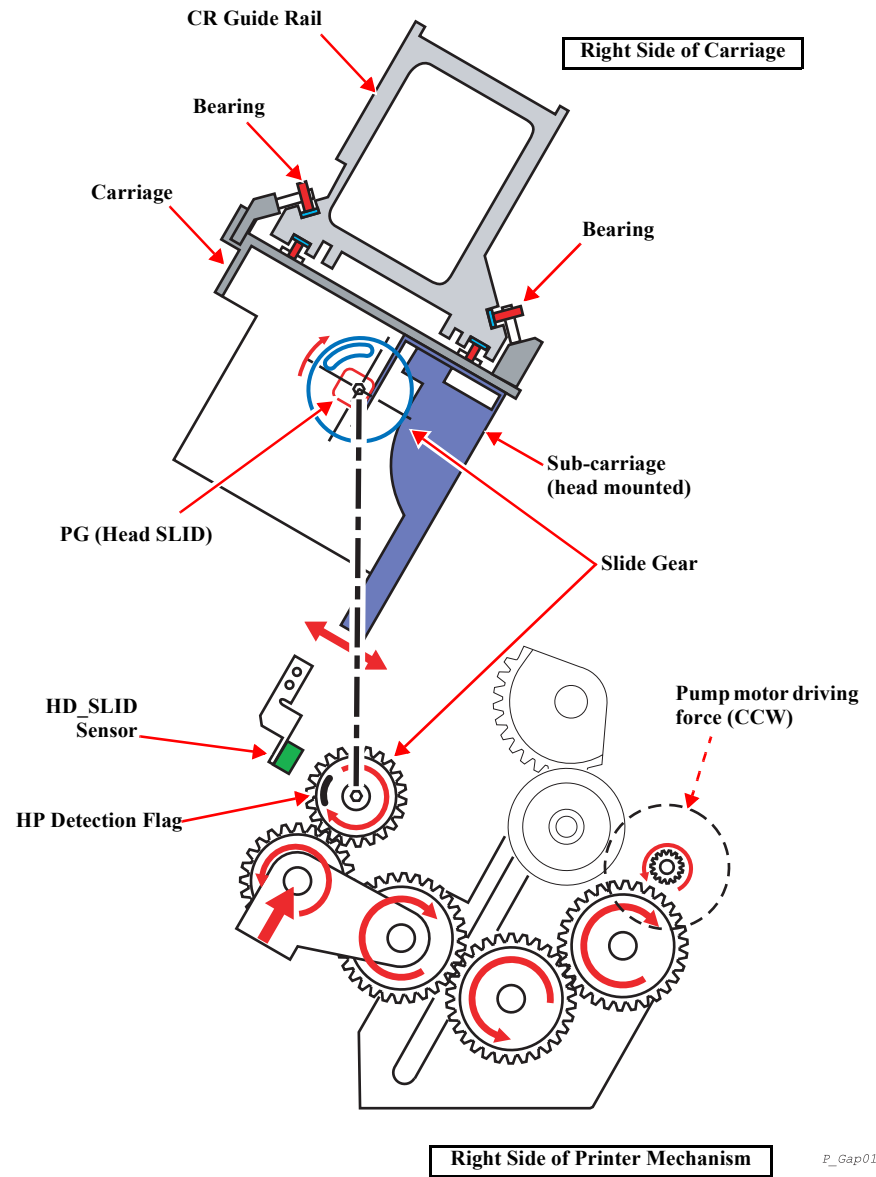

Figure 2-4. Carriage Mechanical Unit and PG Adjustment Unit

- HD_SLID (Head Gap Home Position Detection) Sensor
 This sensor detects the mechanical home position when the position of the sub-carriage (head height from the paper surface) on the carriage undergoes change. A reflective type photosensor is used and the position of the flag on the gear mounted on the camshaft is detected.
 The cam is so shaped as to realize the four head positions relative to the mechanical home position.
 - Detecting distance up to the reflector: 7.5 ± 0.5 mm

NOTE: Error number displayed when the total pulse count has exceeded 1000:
 0001000C Head slide origin detection error (Service Call Error)

Table 2-4. Pulse Positions

Position	Gap Width	Application	Pulse Count from Origin (Converted to 2-2 Phase Excitation)
Large	2.6 mm	Platen gap for thick paper	37
Medium	2.2 mm	Platen gap for paper which can be soiled if setting is for thin paper	121
Small	1.2 mm	Platen gap for thin paper	204
Minimum	0.7 mm	Platen gap for film	287
One round			333

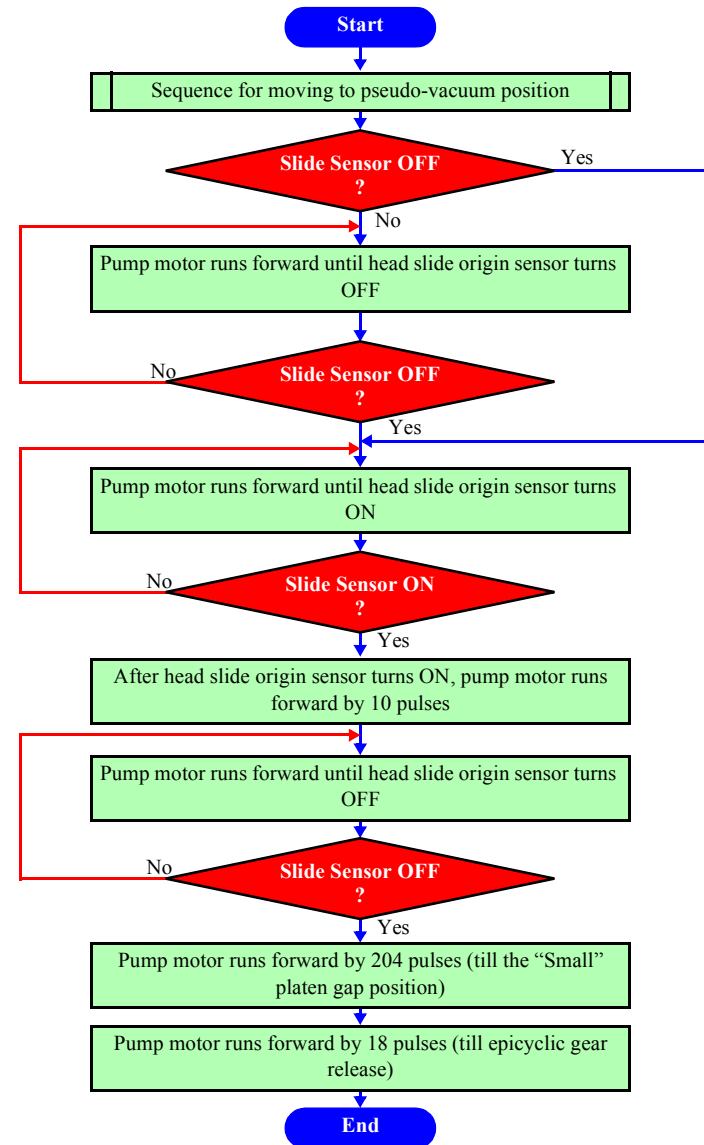

Figure 2-5. Head Slide (PG Change) Initialization Sequence

□ P_EDGE (Paper Width Detection) Sensor

This sensor, mounted at the left side of the cutter unit of the carriage, detects paper edges by moving the carriage.

It detects four points of paper edges, namely, left and right points on the front edge and a front point on the left and right edges of the paper. Each position is calculated from the difference in reflection value between the platen and the paper. A reflective type photosensor is used. Each paper edge position (presence or absence of paper) is determined by an A/D converted value of the output from the photosensor.

During printing, the sensor monitors the left and right edges of the paper to detect a skew.

- Detecting distance up to the paper surface: 7.0mm ± 0.5

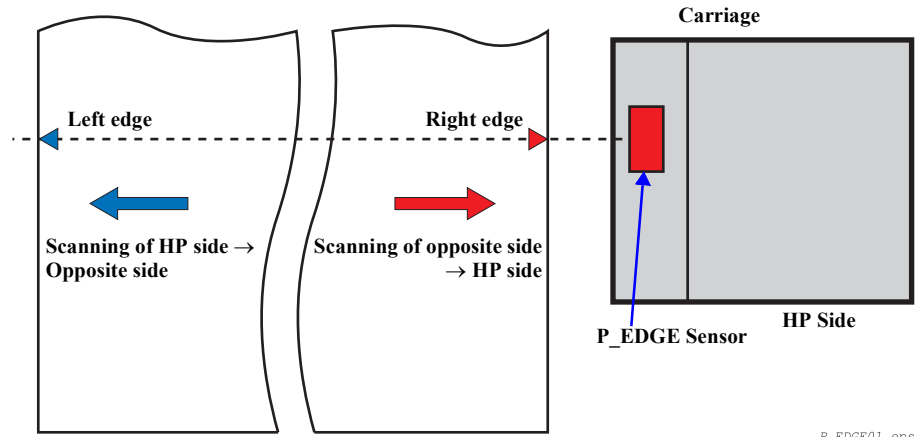

P_EDGE01.eps

Figure 2-6. Carriage Unit Paper Width Detection Sensor

CHECK POINT



- It must be ensured that the reflection value of the least reflective paper is greater than the reflection value of the platen.
- The paper must be free from floating at the detection point.
- If external light, such as sunlight, can enter the sensor due to the construction, mis-detection must be prevented by LED ON/OFF control.
(Same as with Stylus Pro 7000)
- In Stylus Pro 7600/9600, the P_EDGE Sensor works also to detect the paper front edge. (Stylus Pro 7600/9600 does not have the P_FRONT Sensor for exclusive use to detect the paper front edge which is incorporated in the conventional printer models.)

NOTE: It is possible to turn this sensor off by “SelectType” (p.35).

The following pages show paper size detection sequence (left and right edges and front edge).

■ Paper size detection sequence (left and right edges)

Error display:

Set the paper correctly

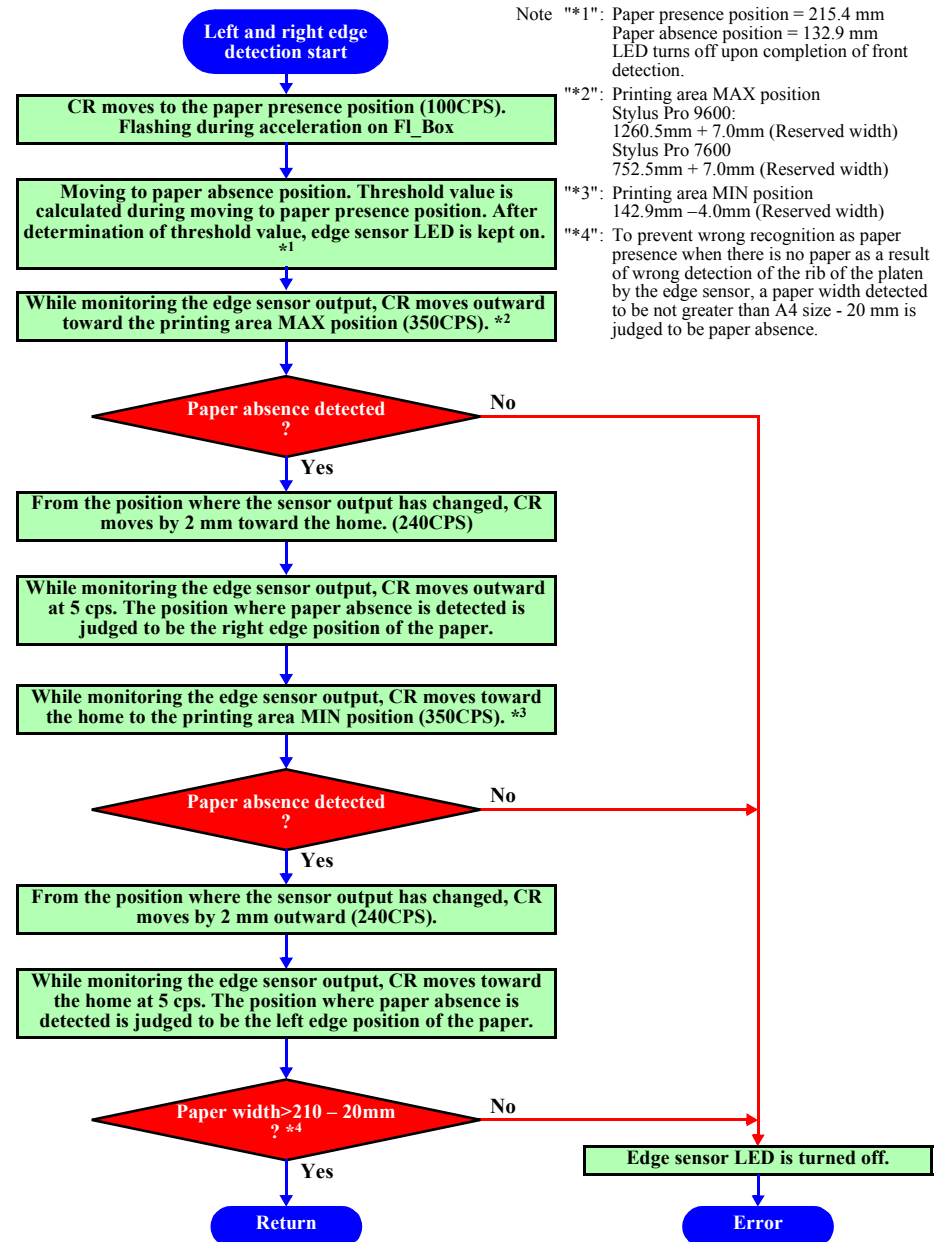
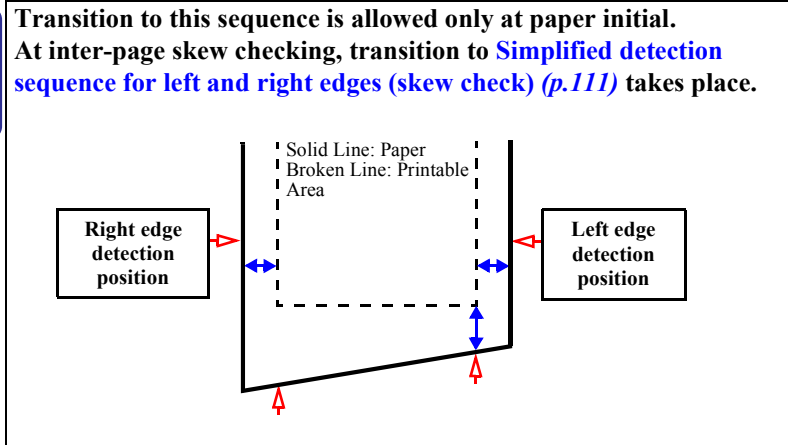

Figure 2-7. Paper Size Detection Sequence (Left and Right Edges)

■ Paper size detection sequence (front edge)

Conditions:

For execution of this processing, the paper level threshold value must be known. (Execute this processing after detection of the right and left edges.)

Error display:

Set the paper correctly

When the paper width detection function is turned off, use the paper size front position as the user paper setting position. (On the assumption that detection is not made by the edge sensors)

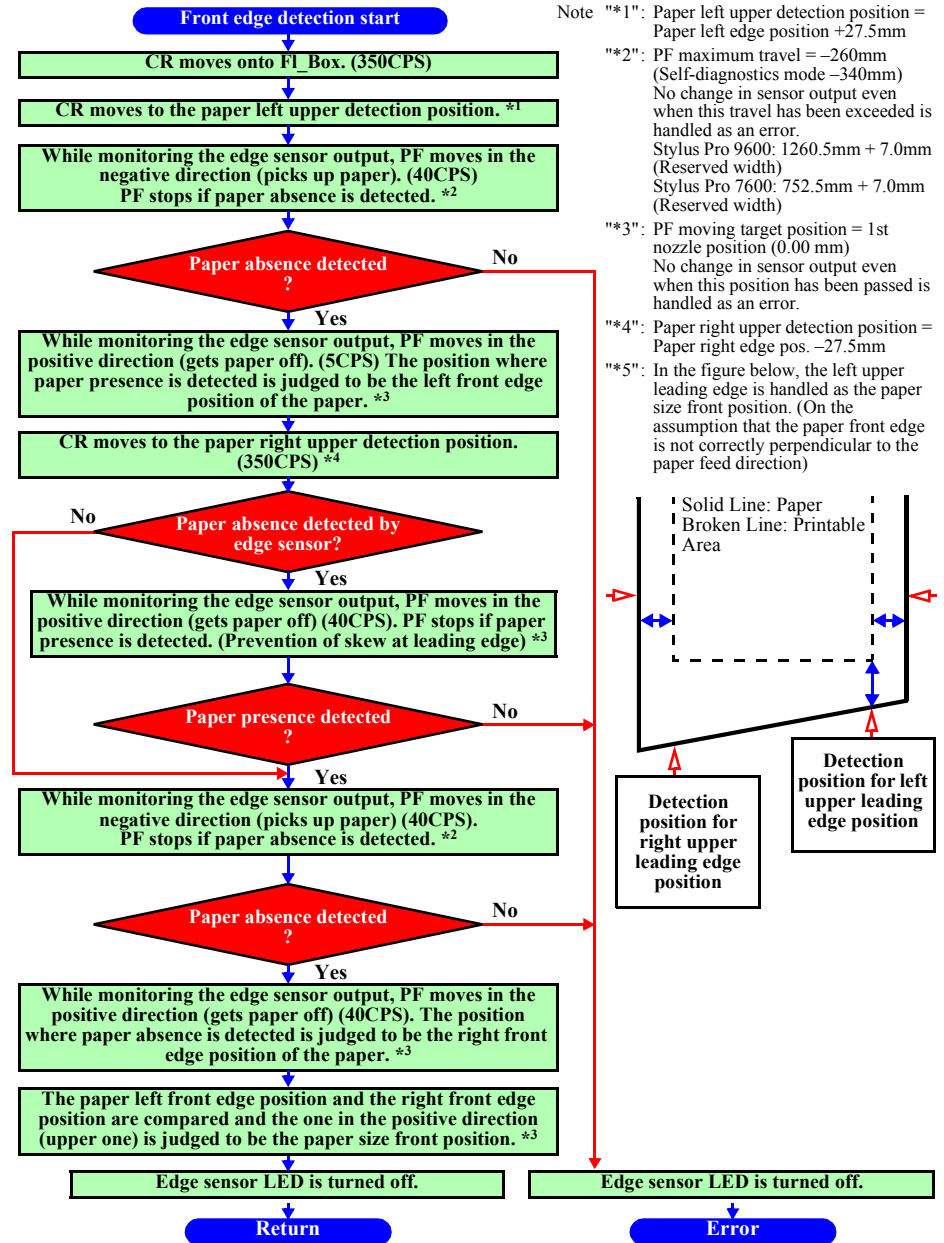

Figure 2-8. Paper Size Detection Sequence (Front Edge)

- Simplified detection sequence for left and right edges (skew check)
When the paper width detection function is turned off, left and right edge detection (skew check) is not carried out.

Error display:

- 1: Set the paper correctly
- 2: PAPER NOT STRAIGHT



Transition to this sequence is allowed only at inter-page skew checking (at cut/eject, etc.) At paper initial, transition to "Paper size detection sequence (left and right edges)" (p.109) takes place.

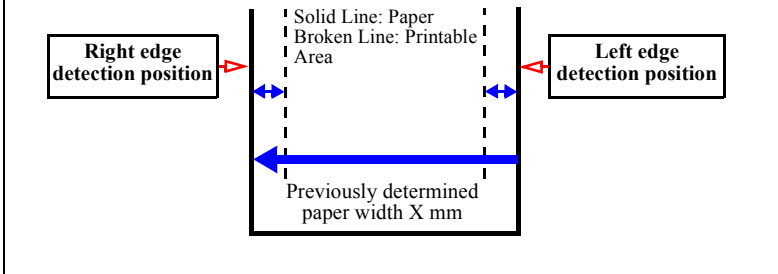

Note ***1**: Paper presence position = 215.4 mm
Paper absence position = 132.9 mm
LED turns off upon completion of skew check.
***2**: Printing area MIN position = 142.9 mm - 4.0 mm (Reserved width)
A4 size (210.0 mm) - 20.0 mm = 190.0 mm

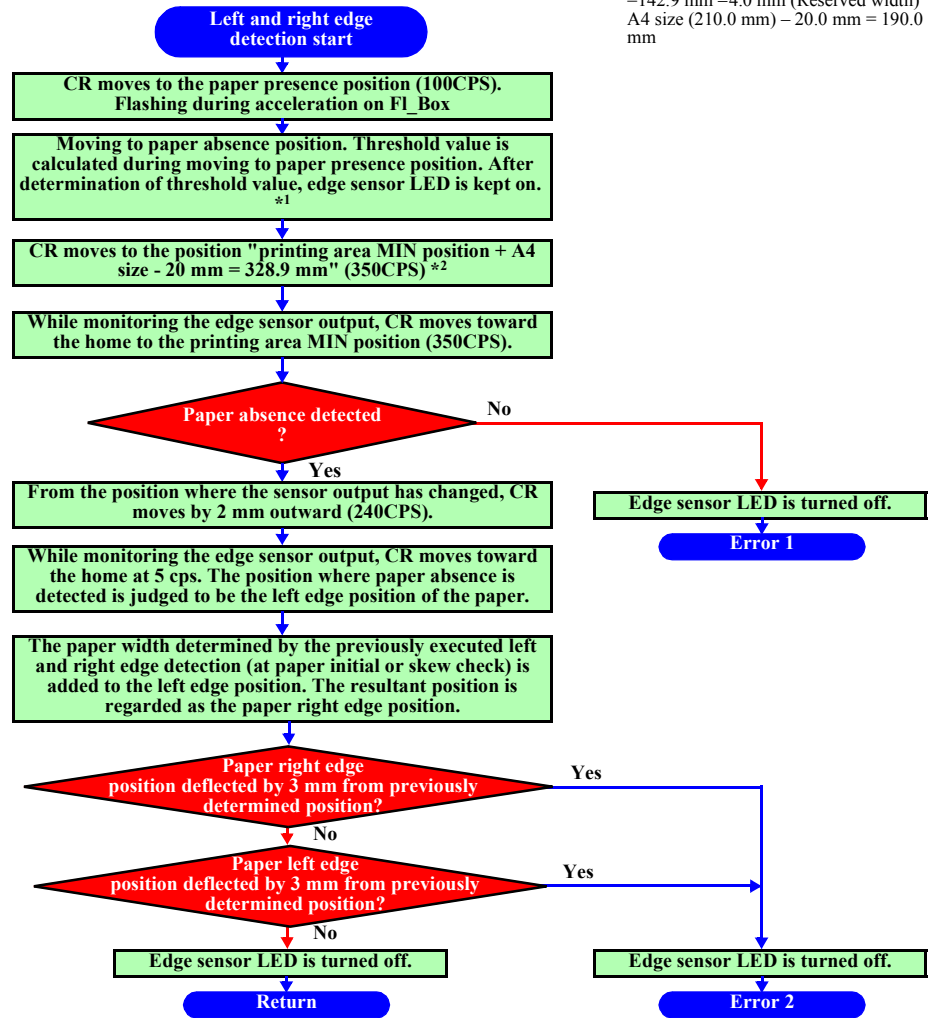

Figure 2-9. Simplified Detection Sequence for Left and Right Edges (Skew Check)

- Cutter Solenoid
This DC solenoid controls the cutting pressure of the roll paper cutter. It also unlock the carriage.
This function can be set On or Off using the Panel buttons.

NOTE: See “1.2.6.3 Cutting Specification” (p.22)

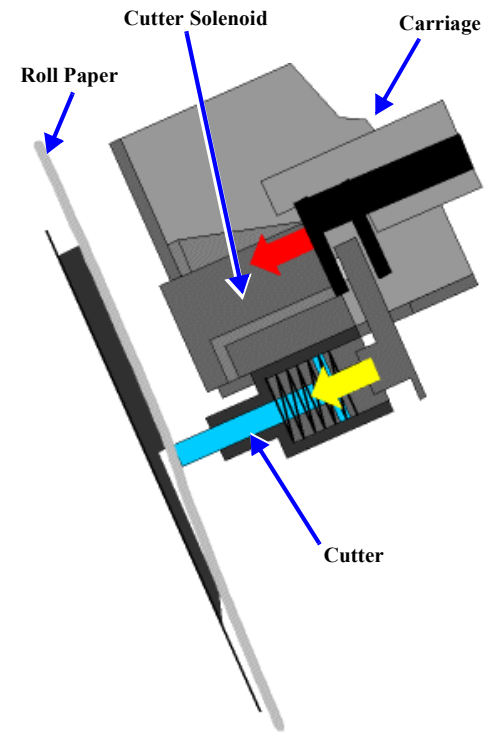

Figure 2-10. Carriage Unit Cutter Solenoid

2.2.2 Paper Feed Assembly

This printer uses friction feed to carry out highly precise feeding of roll paper and cut sheets, and comprises a unique paper feed mechanism.

The paper feed mechanism unit is configured from a grid roller (one piece construction), and pressurizing and follower roller assemblies mounted on the back of the CR guide rail opposite the front surface.

- PF motor
 The PF motor is a DC motor. The grid of the loop scale mounted on the Grid Roller is read by the PF_ENC sensor and the output pulse is fed back to control the motor. This feedback control ensures high printing accuracy.
 Driving of the grid roller is accomplished by the PF motor via the PF timing belt which attaches to a reduction pulley that is connected to the grid roller.

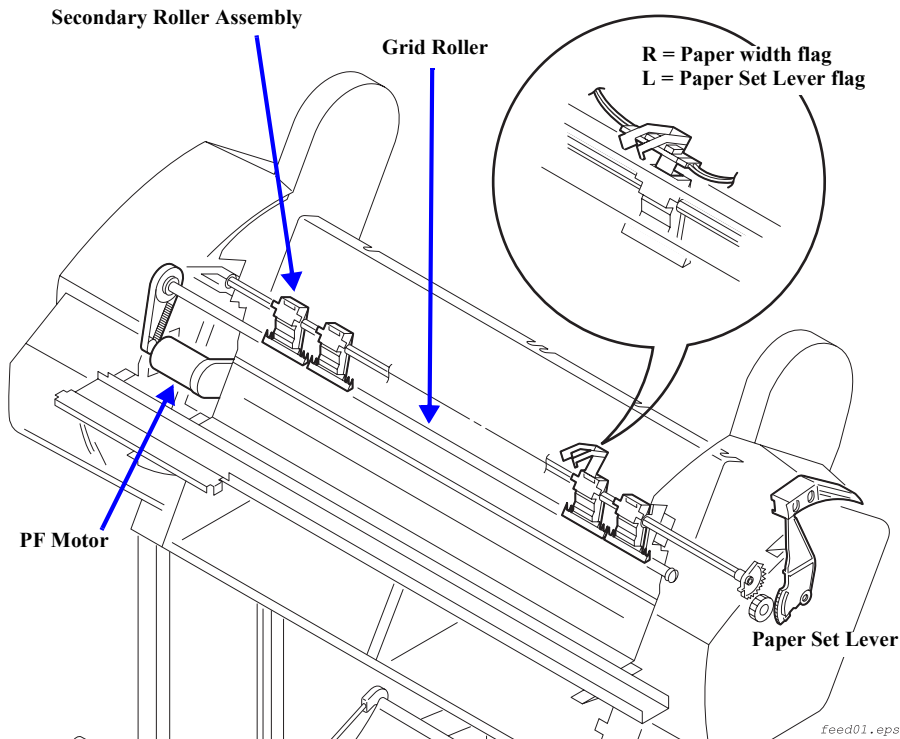

Figure 2-11. Paper Feed Mechanism Unit 1/2

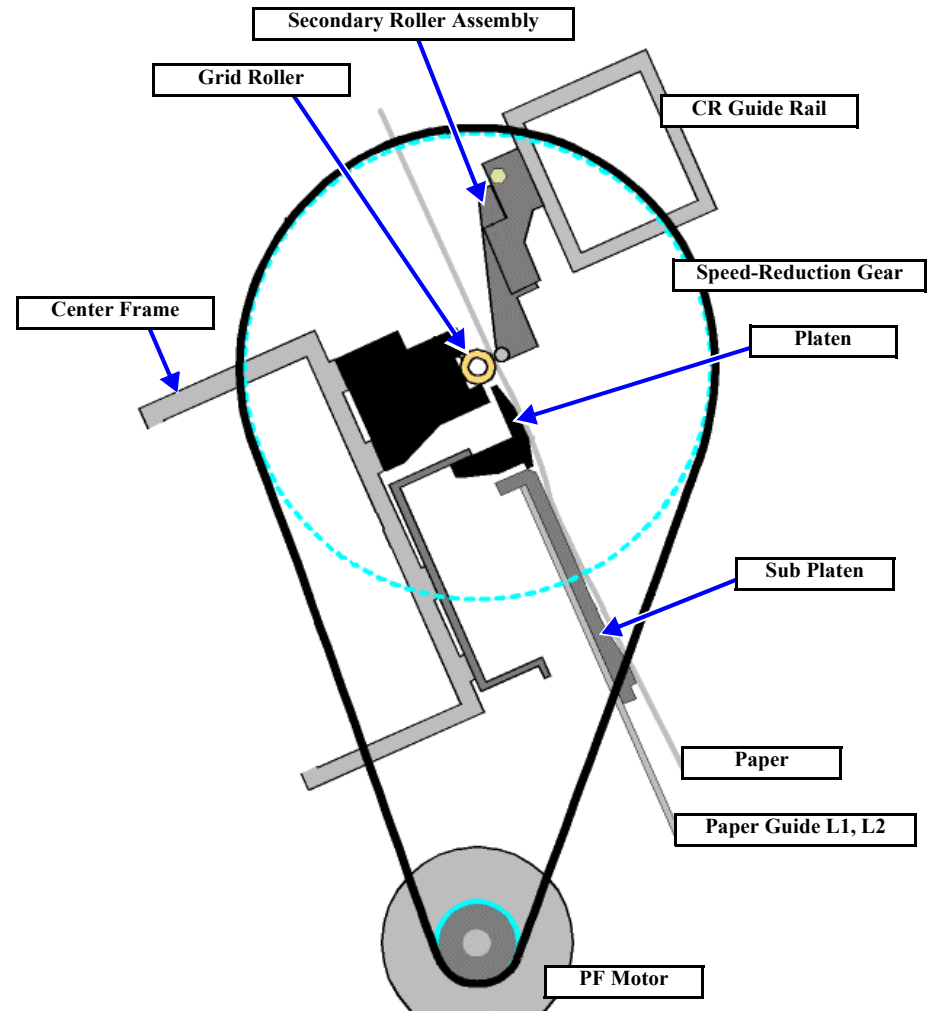

Figure 2-12. Paper Feed Mechanical Unit PF Rail Unit

□ Paper Suction Fans

The printer is equipped with suction fans in the lower space in the rear. The space in the column direction behind Paper Guide L2 is divided into 2 compartments (Stylus Pro 7600) or 3 compartments (Stylus Pro 9600), and one fan is mounted in each compartment. By drawing air through multiple holes punched in Paper Guide L2 in the back surface of the paper path and blowing it out through the rear of the printer housing, suction is applied to the surfaces of Paper Guides L1 and L2 and the paper is stabilized (prevented from flying up) as it passes through the printer. The suction fans undergo air flow control (fan rotation duty control), which is carried out by firmware control based on the printer's operating state (when paper is set and during printing, etc.) and the type of paper used.

NOTE: Fans mounted

Stylus Pro 7600: 2 fans

Stylus Pro 9600: 3 fans

The following sensors aid in the paper feeding process.

□ P_REAR sensor

This sensor is attached to the Upper Paper Guide and is an optical (photo-reflective) sensor. This sensor detects the rear edge of the paper and detects the front edge when the paper is first loaded in the paper path. The position of this sensor is stored in EEPROM.

□ Paper set lever, paper thickness detection (P_THICK, P_THICK_0.3)

■ P_THICK_0.3 Sensor: Transmission type photosensor, left side.

■ P_THICK Sensor: Transmission type photosensor, right side.

The mechanism is so designed that the threshold values for paper thickness are 0.3 ~ 0.4 mm (P_THICK_0.3 sensor) and 0.8 ~ 0.9 mm (P_THICK sensor). The sensors operate just when the pressure lever is brought down.

The designed detection values of the sensors for the UP and DOWN positions of the pressure lever are 0.3 mm and 0.8 mm. The pressure lever in the UP position is detected by a combination of both sensors.

“Thick paper state” occurs when the connections are open.

There is no error processing since this mechanism can not determine whether it has broke down or not.

Since the mechanism is always in recognition of thick paper, printing on thin paper is carry out with the platen gap kept large.

Table 2-5. Modes

Paper Thickness	Shield Plate		Sensor Output	
	P_THICK_0.3	P_THICK	P_THICK_0.3	P_THICK
Below 0.3 mm	Absent (Open)	Absent (Open)	L	L
0.3 mm to 0.8 mm incl.	Present (Closed)	Absent (Open)	H	L
0.81 mm or above	Present (Closed)	Present (Closed)	H	H
Connector not connected	-	-	H	H
Pressure release (Hi-Up)	-	-	L	H

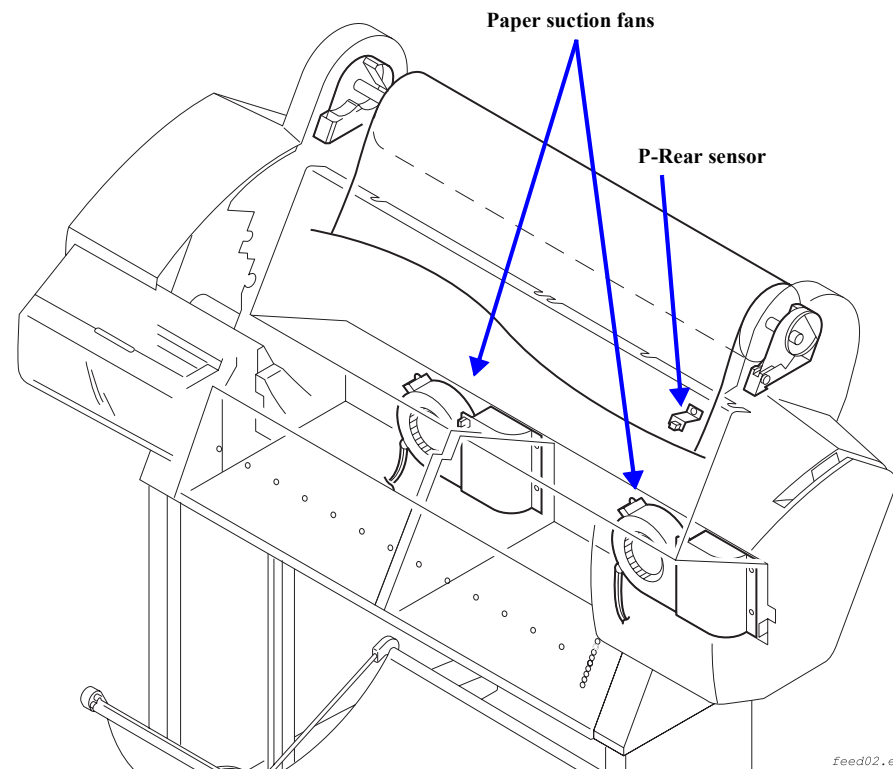

Figure 2-13. Paper Feed Mechanical Unit (Stylus Pro 7600) 2/2

2.2.3 Cleaning Mechanism

The cleaning mechanism in this printer is compatible with the cleaning mechanism in the Stylus Pro 5000/9000. The cleaning mechanism is located on the right side of the printer. The waste ink from the cleaning mechanism is channeled to the waste ink pad (Maintenance Tank) in the lower right side through the tube.

The cleaning mechanism components are installed above the sub-frame and some are fixed on the main frame as shown below.

- ❑ Pump assembly (head cleaner)

When the head is in the capped position (valve closed), the pump motor creates a vacuum that sucks ink from the nozzles. This is used for removing ink from the nozzles and nozzle plate, initial ink charge, as well as cleaning. The waste ink flows through one small tube to the waste ink pads.
- ❑ Head cleaner

The head cleaner has felt on one side and rubber on the other, and is used to wipe or rub off ink and foreign materials from the nozzle surface.
- ❑ Pump motor (stepping motor)

The pump motor runs normally (the pump wheel turns clockwise as viewed from the pump wheel side) and reverses (the pump wheel turns counterclockwise) to execute the following functions:

 - Clockwise rotation (CW):
pump assembly drive for cleaning and so on (Suction, wiper setting)
 - Counter clockwise rotation (CCW):
Pump release, wiper reset, HD_SLIDE (head gap adjustment) cam drive. See "Platen Gap Adjustment Unit" (p.106).

Table 2-6. Pump Drive Modes

Suction Speed Name (Drive Mode)	Pump Wheel Revolving Speed	Pump Wheel Revolving Speed	Motor Frequency (2-2 phase conversion)
Low speed (IS5)	0.46 rev/sec	0.15 ml/sec	186 Hz
Standard (IS4)	1.6 rev/sec	0.6 ml/sec	648 Hz
High speed (IS3)	2.6 rev/sec	0.9 ml/sec	1053 Hz
Super-high speed (IS2)	4.2 rev/sec	1.1 ml/sec	1702 Hz
Super-high speed (IS1)	5 rev/sec	1.2 ml/sec	2026 Hz

Note : The values for Motor Frequency above, given only for information, are obtained by 2-2 phase drive conversion with a drive system consisting of the pump wheel with P.C.D of $\phi 30.4$ and motor gear with P.C.D of $\phi 6$.

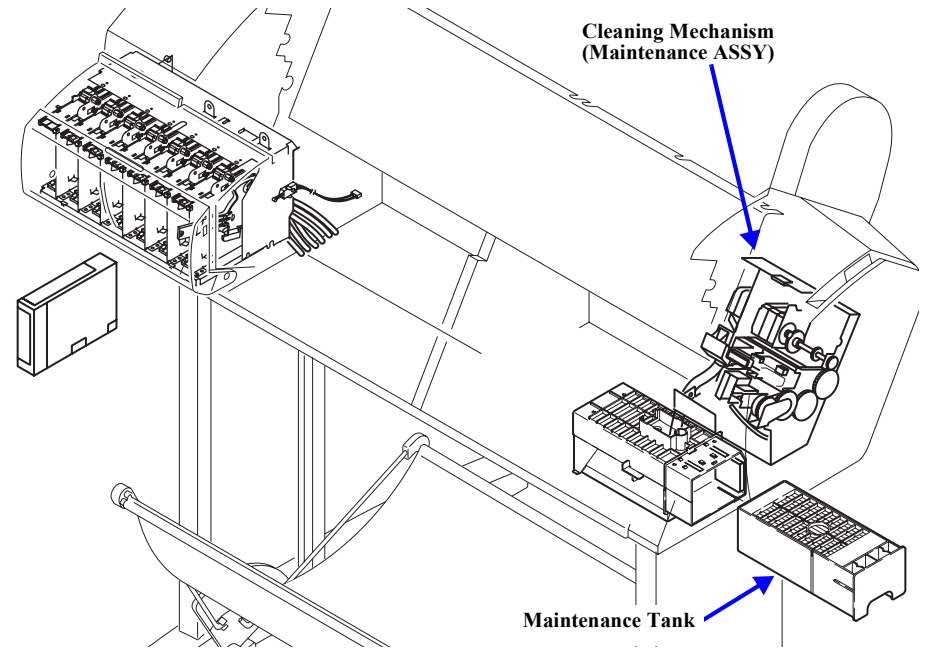

Figure 2-14. Cleaning Mechanism Components

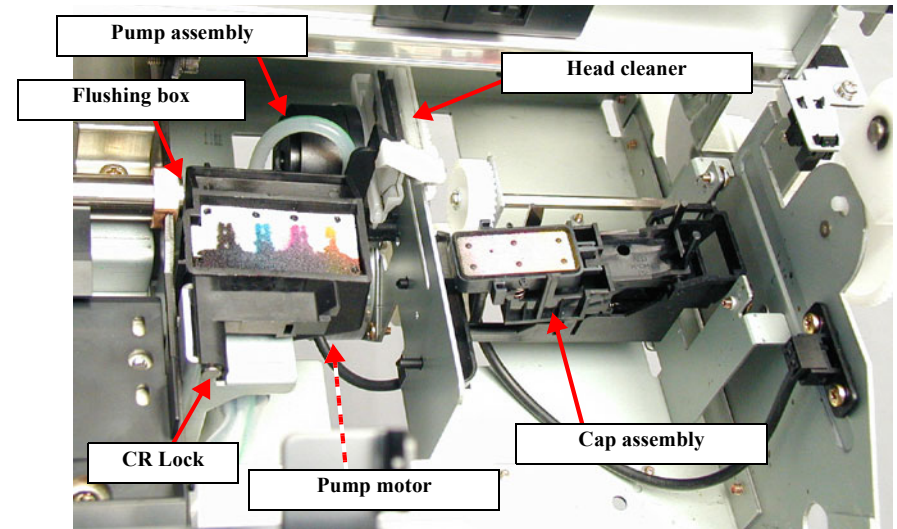

Figure 2-15. Cleaning Mechanism Components

- ❑ Cap assembly
When not printing, the print head (should) rest on the cap assembly to ensure that the nozzles don't clog. Also, the print head is in the capped position during ink charging, cleaning, and so on.
- ❑ Flushing box
Flushing (dummy printing) is performed over the flushing box, and the flushed ink flows through the pipe to the waste ink pads.
- ❑ CR Lock Mechanism
If the carriage moves from the printable area to beyond the capping (CR_HOME) position to the right, the carriage moving prevention lock is engaged. The CR lock mechanism uses the cutter solenoid in common. When the cutter solenoid goes ON in the capping position, the CR lock is released.
- ❑ Maintenance Tank (Waste ink absorber)

NOTE: The Ink System Terms used in the above text are explained in the following table.

Table 2-7. Explanation of Operation

Operation	Explanation
Carriage (CR) Lock	<ul style="list-style-type: none"> • This is the carriage stop position when the power is Off. • The time when the carriage is in the standby position (home position) with the power On and with no paper loaded and no print data to print.
Ink Initial Filling	<ul style="list-style-type: none"> • This is the operation where the head is filled with ink for the first time. When the first ink cartridge is inserted (after all 6 colors have been inserted), the ink initial filling operation is performed automatically. • The initial filling flag is set when the printer is shipped from the factory, then after this operation, the initial filling flag is reset. The initial filling flag is also set after the “Input Rank” (p233) is run.
Flushing	<ul style="list-style-type: none"> • In order to prevent the viscosity of the ink inside the head nozzles from increasing, the ink inside the flushing box is flushed out. • Flushing is done when paper is set, when printing from the standby state, during continuous printing, during paper Eject, during paper cutting, etc.

Table 2-7. Explanation of Operation (continued)

Operation	Explanation
Empty Suction Operation	<ul style="list-style-type: none"> • After ink is sucked up, the remaining ink inside the cap is sucked up and the ink adhering to the head nozzle surface is removed. • Through flushing, etc., the ink that has accumulated in the cap is sucked up and discharged.
Wiping Operation	<p>The carriage is moved from right to left along the rubber side of the wiper (the right half of the wiper plate) incorporated in the pump unit so that the head surface is rubbed with the rubber of the wiper.</p> <p>Purpose:</p> <ul style="list-style-type: none"> • Before ink suction, removes the ink and other substances adhering to the head surface. • Ensures close contact of the cap.
Rubbing Operation	<p>The carriage is moved from left to right along the felt side of the wiper (the left half of the wiper plate) incorporated in the pump unit so that the head surface is rubbed with the felt of the wiper.</p> <p>For easy removal of adhering substances, the nozzle surface is wetted before rubbing operation by suction of a small amount of ink.</p> <p>Purpose:</p> <ul style="list-style-type: none"> • Removes ink and other substances adhering strongly to the head surface. • Ensures close contact of the cap.
Capping	<p>In order to prevent the ink viscosity from increasing while it is being kept, a rubber cap is placed over the print head nozzles when entering a shutdown operation.</p>

2.2.4 Ink Supply Mechanism

Stylus Pro 7600/9600 is so constructed that the 7 cartridges for different colors are installed in the respective ink holders (I/H) in the left area of the printer. A projection and unique marking are placed on each color ink cartridge case to prevent wrong insertion so that the correct cartridge is inserted in the right direction.

- Explanation of valve mechanism mounted on the cartridge
The valve automatically opens and closes when the ink cartridge is mounted and removed.

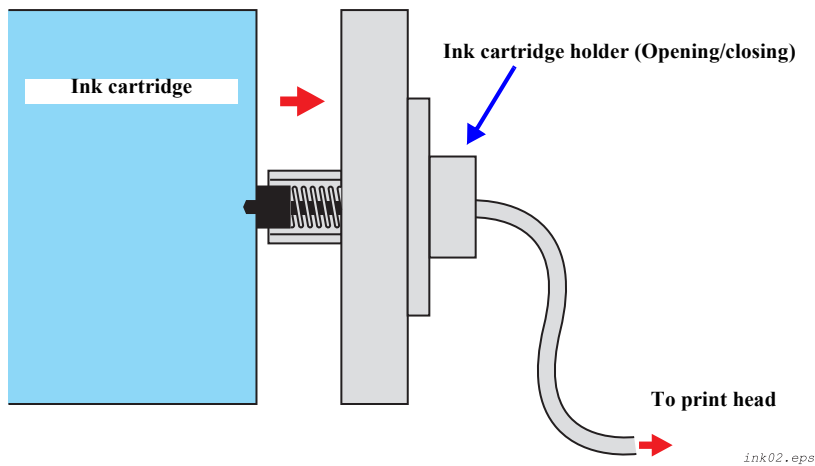

Figure 2-16. Valve Mechanism

The ink flow is as shown below.

Each color's ink cartridge → Each color's I/H (Ink Holder) → Each color's ink tube → Each color's head dumper (carriage) → Print Heads

The information in EEPROM of each color ink cartridge is sent through the CSIC Relay Board in each ink holder and stored in memory on the CSIC Board. The CSIC Board stores various pieces of information, such as ink colors and remaining amount of ink. (Refer to *"Ink information menu (p.69)"*)

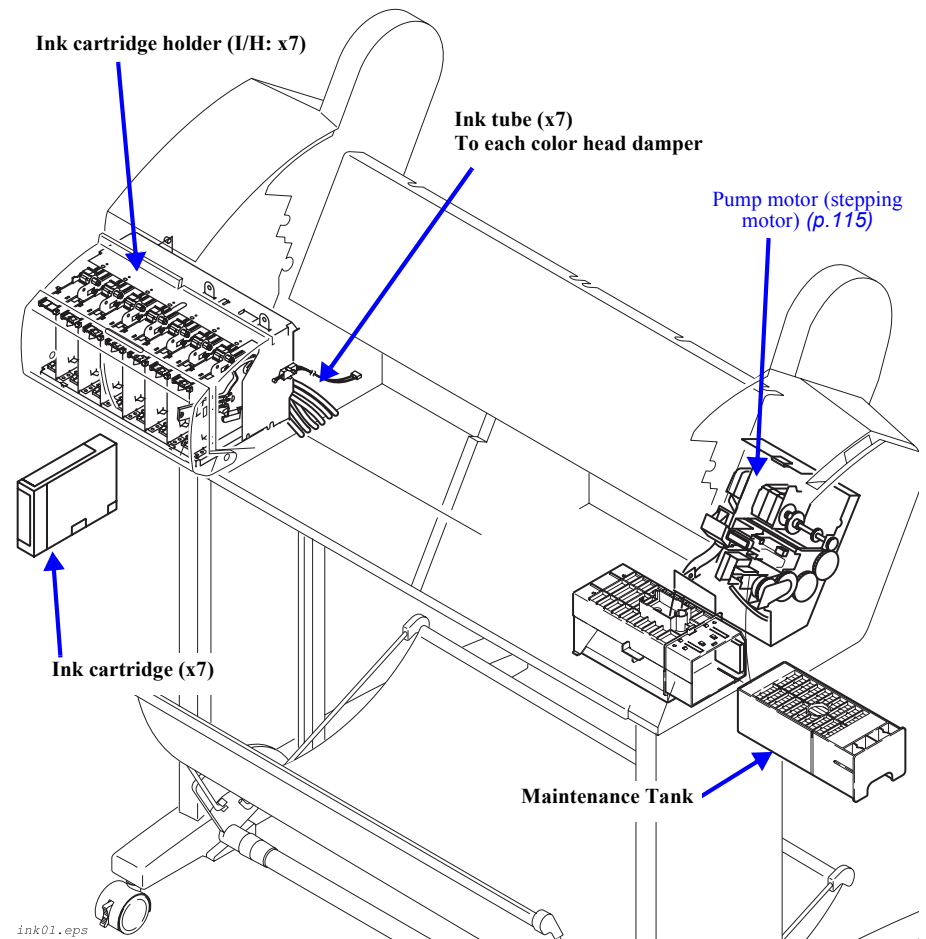

Figure 2-17. Ink Supply Mechanism

2.2.5 Others

COVER SENSOR

In order to detect whether the front cover on the lower front of this printer is open or closed, a cover sensor is mounted on the printer on the left side where the front cover opens and closes.

This sensor carries out control of operating and stopping of the CR motor and PF motor drive circuits via the MAIN board's logic circuit after detecting the cover's status. This control is the same when the paper support level is in the release state.

CIRCUIT BOARD PLACEMENT

The panel unit is located in the right front of the printer and the AC inlet, power supply circuit board and the MAIN circuit board are mounted in the compartment on the printer's rear side.

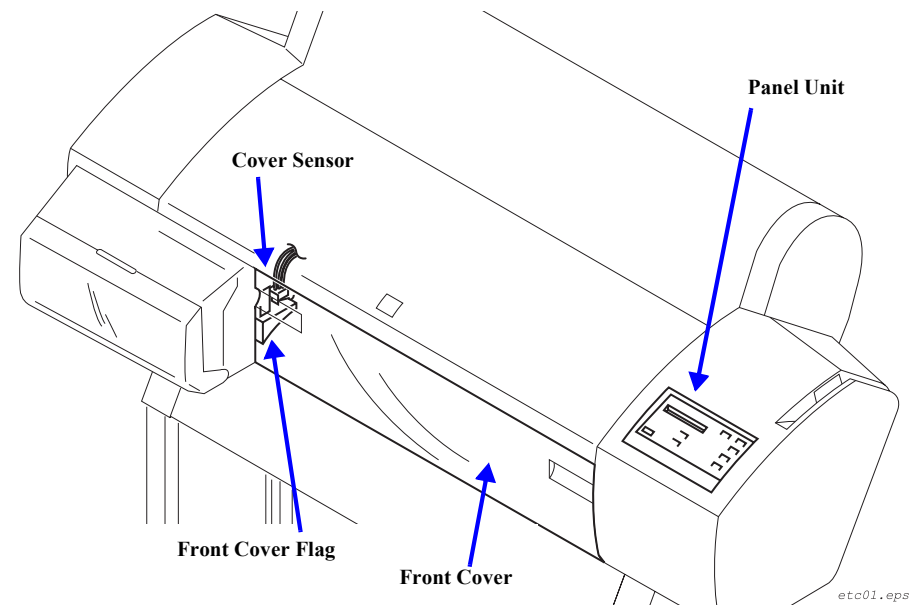

Figure 2-18. Cover Sensor Panel Unit

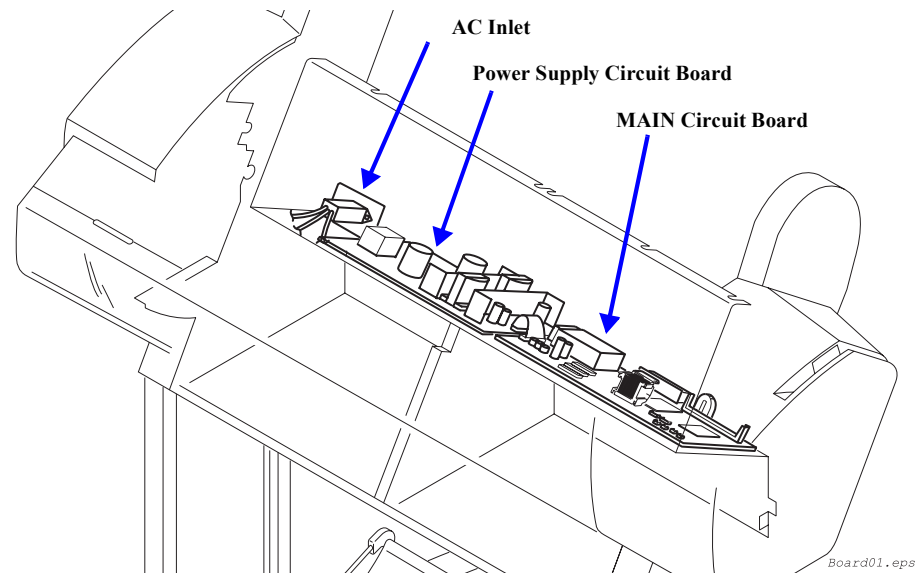

Figure 2-19. Circuit Board Layout

2.3 Outline of Control Circuit Board

This section describes the operation of C472MAIN Board, which controls and drives the printer mechanism of Stylus Pro 7600/9600.

NOTE: For details of each circuit, refer to Chapter 7 Appendix (p.281).

□ Explanation of major elements on C472MAIN Board

Table 2-8. Major Elements

Name/Code	Location	Function
SH-3 HD6417709A	IC10	32 bit RISC-CPU • Drive clock frequency = 100 MHz
CY24242PVC	IC602	System clock controller • CPU clock • SDRAM clock • Clock for I/O control
E09A42AA	IC607	Custom ASIC 1. Print data processing • Rasterizer • Head drive control 2. Mechanism control (motors and solenoids) 3. Sensor control
E05B80CD	IC35	Custom ASIC • External I/O control IEEE1284 (bidirectional parallel) I/F Type-B port
E09A41RA	IC34	Custom ASIC • Head drive voltage waveform generation control
E05C02BA	IC603	Custom ASIC • USB-I/F (2.0) control
Flash Memory	IC9	Flash Memory (16Mbit) • For storage of control program (firmware) • Saving of various setting parameters and control information
SD-RAM	IC4/6 IC600/601	System memory * 128mbit x 16
L6203	IC31/32	PF/CR Motor Drivers IC • PWM constant current drive control
LB11847	IC30	Pump Motor Driver IC

Note " * ": Stylus Pro 7600: IC4/6 only (32MByte)
Stylus Pro 9600: IC4/6 and IC600/601 (64MByte)

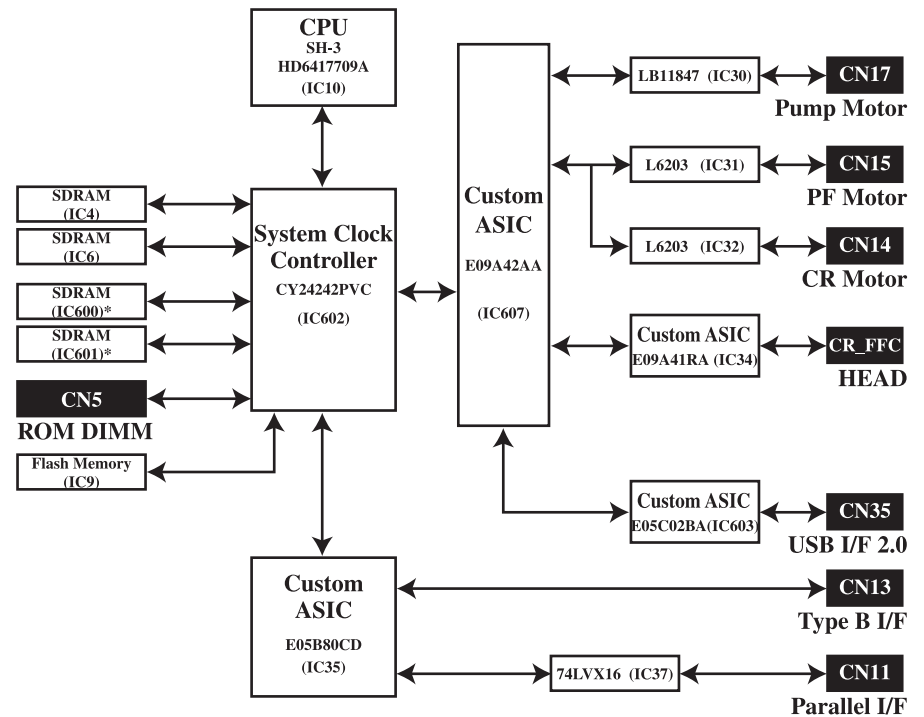

Block01.eps

Figure 2-20. C472MAIN Board-Circuit Block Diagram

2.4 Outline of Power Supply Circuit Board

The 100 V AC power from the wall outlet is supplied via the power cable, an accessory of Stylus Pro 7600/9600, into the Inlet of the printer and to the Power Supply Circuit Board.

The power switch constitutes a secondary power switch system. The secondary power switch system operates as follows: even with the power switch turned off, the Power Supply Circuit Board is operating by a slight power as long as the power cable is connected.



Even after the power switch is turned off, the Power Supply Circuit Board does not stop operating immediately, but power is kept on until the ink system ending sequence is completed. Do not disconnect the power cable or do not shut off power by turning off any power switch other than that on the printer.

The Power Supply Circuit Board is equipped with a fuse for overcurrent protection. Table 2-9 below indicates the rating of the fuse:

Table 2-9. Fuse Rating

Input Voltage Range [V AC]	Fuse Rating
100 +/- 10%	125 V AC / 6.3A

There are three control signals between the C472MAIN Board and the Power Supply Circuit Board. Table below describes details of the control signals:

Table 2-10. Control Signals between C472MAIN Board and Power Supply Board

Signal Name	Function	
REM_ON (MAIN→ Power Supply)	Operating	Turned ON/OFF by C472MAIN Board. <ul style="list-style-type: none"> When these terminals are shorted, the drive system power supplies 28 VDC and 42 VDC are active.
	Off	<ul style="list-style-type: none"> When these terminals are open (= L), the drive system power supplies 28 VDC and 42 VDC are 0 VDC. The 5 VDC power is not controlled with these terminals.
AC_OFF (MAIN← Power Supply)	Operating (= H)	When each output from the Power Supply Circuit Board has become inactive because of turning off of the power switch or when the input voltage has dropped below the rated voltage value, "H" signal is sent to the C472MAIN Board.
	Off (= L)	The power switch is turned on and the Power Supply Circuit Board Unit starts operating so that each output becomes active. "H" signal is sent to the C472MAIN Board.
POW_ON/OFF (Panel / MAIN→Power Supply)	Operating	Connected to the power switch on the Panel Unit. <ul style="list-style-type: none"> These terminals are shorted when the switch is ON. The Power Supply Circuit Board becomes active.
	Off	<ul style="list-style-type: none"> These terminals are open when the switch is OFF. The Power Supply Unit keeps operating for about ten and several seconds to a few minutes and then turns off.

CHAPTER

3

TROUBLESHOOTING

3.1 Outline

This section explains procedures for rapid and efficient troubleshooting if trouble occurs in the printer.

3.1.1 Introduction

First of all, when performing troubleshooting, the following basic parts should be checked.

1. Look in the printer for any foreign matter and make sure there is nothing there to hinder normal operation.
2. Carry out printing by setting the printer in the "Pause" state, then press the [SelcType] button 2 times. Next using the [Paper Feed] switch in the "TEST PRINT MENU," select "STATUS CHECK", then press the [Enter] switch and print.
From the status sheet, you can Check to see if the cause of the trouble is that the printer (either the printer unit itself or some major unit) is at the end of its service life, and check the user inherent panel settings, etc.
3. There should be no market soiling of the outside or the inside of the printer. If it is extremely soiled, carry out cleaning.
4. Each of the units and parts in the printer should not be missing or damaged, and should have the normal shape and configuration.
5. Each of the harnesses should be undamaged, and should be correctly connected to the relevant connector (perpendicularly and in the correct direction).
6. Each cam and gear in the printer mechanism should have no uneven wear or be overly worn, and the combinations should be correct.
7. Each type of rubber roller in the printer mechanism should be cleaned and it should be ascertained whether the cause of the trouble is because of dirt or due to some other cause.
8. Each type of rubber roller in the printer mechanism should not be unevenly worn or excessively worn, and their combinations should be correct.
9. As necessary, initialize the NVRAM on the C472MAIN Board (return the individual customer settings and panel settings to the factory settings). Carry out initialization by executing "INIT. NVRAM" from the "CLEAR COUNTERS MENU" in "Maintenance Mode 2."
10. Make certain that the DIP Switches and Jumpers have been set correctly. (Refer to "DIP Switch and Jumper Setting at Factory before Shipment" (p.209))



When disassembling the printer, turn the printer's power switch Off, then after making sure that the panel display is off, pull out the power cable from the outlet and disconnect the interface cable.



- **Only the specified printer tools should be used so as to maintain the printer's quality.**
- **Only the specified lubricants and adhesives should be used.**
- **The specified adjustments should definitely be carried out.**

3.2 Error Display

The printer displays the relevant error message on the LCD and the error status by LEDs. At the same time, it stops not only printing operation but also receiving data from the host PC. (Among the interface signals, the “-ERROR” signal is turned “low” and the “BUSY” signal is turned “high” to inhibit data input.)

3.2.1 Errors

Errors, Warnings and service call errors (fatal errors) are described below.

3.2.1.1 Error Indications on LCD

Table 3-1. Error Indications on LCD

LCD Panel Message	Printer Status	Refer to
SERVICE REQ. nnnnnnnn	Fatal error*	
COVER OPEN	Cover open error	p.127
LOAD PAPER	Paper set lever is released during operation	p.126
PAPER JAM	Paper jam	p.127
INK OUT	Ink out error	p.130
NO INK CARTRIDGE	No ink cartridge	p.130
INVALID CARTRIDGE	Wrong ink cartridge	p.130
SET INK CARTRIDGE	Defective ink cartridge	p.131
PAPER OUT	Paper out error	p.126
COMMAND ERROR	<ul style="list-style-type: none"> Ink sequence currently executed Paper currently initialized Timer IC reset /NVRAM clear 	—
LOAD XXX PAPER	<ul style="list-style-type: none"> Wrong setting with roll paper and sheet (Roll paper) Wrong setting with roll paper and sheet (Sheet) 	p.126
RELOAD PAPER	Problem with paper output (sheet)	p.129
MAINTENANCE TANK FULL	Maintenance tank full	p.131
PAPER NOT CUT	Paper cutting error	p.128

Table 3-1. Error Indications on LCD (continued)

LCD Panel Message	Printer Status	Refer to
LOWER PAPER SET LVR	Paper set lever is released	p.127
REMOVE PAPER	Paper is too thick for cleaning	
RELOAD PAPER	Paper check error	p.129
PAPER NOT STRAIGHT	Paper not straight	p.128
INVALID CARTRIDGE	Non-genuine cartridge	p.130
SET INK LEVER	Ink lever released	p.130
NO MAINTENANCE TANK	No maintenance tank	p.131
COMMAND ERROR	Command error	p.131
OPTION I/F ERROR	Type-B I/F error	p.128

Note : The status can't be replied during service call.

3.2.1.2 Warning Indications on LCD

Warning warns the user of the occurrence of a corresponding event by replacing the “READY” or “PRINTING” message on the LCD with the warning message. But it has no effect on any other operations of the printer.

The warning message will not be cleared until the cause is resolved.

Table 3-2. Warning Indications on LCD

LCD Panel Message	Printer Status	Refer to
INK LOW	Photo Black Ink Low	<i>p.132</i>
	Cyan Ink Low	
	Magenta Ink Low	
	Yellow Ink Low	
	Light Cyan Ink Low	
	Light Magenta Ink Low	
	Light Black Ink Low	
	Matte Black Ink Low (K1)	
	Matte Black Ink Low (K2)	
MAINTENANCE TANK ALMOST FULL	Maintenance tank full warning	<i>p.132</i>
MAINTENANCE REQ. nnnn	Maintenance request (CR motor life)	<i>p.132</i>
	Maintenance request (Set RTC date)	
	Maintenance request (Head life)	

3.2.1.3 Service Call (Fatal) Errors

Table 3-3. Service Call (Fatal) Errors

Error Code	Description	Refer to
00000101	CR motor life	p.134
00010000	PF motor encoder check error	p.135
00010001	PF motor out of step	p.135
00010002	PF motor overcurrent	p.136
00010003	PF motor in-position time-out	p.136
00010004	CR motor encoder check error	p.137
00010005	CR motor out of step	p.137
00010006	CR motor overcurrent	p.138
00010007	CR motor in-position time-out	p.138
00010008	Servo interrupt watchdog time-out	p.139
00010009	System interrupt watchdog time-out	p.139
0001000A	CR home position sensor error	p.139
0001000B	PF home position sensor error	p.139
0001000C	Head slide (PG) home position sensor error	p.140
0001000F	CR motor PWM output faulty	p.140
00010010	PF motor PWM output faulty	p.141
0001001B	Head driver (TG) temperature error	p.141
0001001D	CR servo parameter error	p.142
0001001E	PF servo parameter error	p.142
00010020	CSIC reed/right error	p.143
00010022	Ink type error (setting on printer body side)	p.143
00010023	RTC analysis error	p.143
00010025	CSIC ROM communication error	p.144
00010026	RTC communication error	p.144
00010028	Head error	p.144
00010029	Unidentified NMI	p.144
0001002A	CR ASIC ECU error	p.144
0001002B	PF ASIC ECU error	p.144
00020000	NVRAM error	p.144

Table 3-3. Service Call (Fatal) Errors (continued)

Error Code	Description	Refer to
00020002	SDRAM error	p.145
00020003	BOOT program SUM error	p.145
00020009	Flash memory SUM error	p.145
0002000A	Program load error	p.145
0002000B	Internal memory shortage error	p.145
0002000C	Review error	p.146
10000E0	CPU address error (load misalignment)	p.146
10000100	CPU address error (storage misalignment)	p.146
10000180	CPU reserve command code exception error	p.146
100001A0	CPU slot illegal command exception error	p.146
100005C0	CPU DMA address error	p.146
10000xxx	CPU error	p.146

3.2.2 Errors

3.2.2.1 Paper End/End of roll

Table 3-4.

Item	Description
LCD PANEL MESSAGE	PAPER OUT
LED STATUS	“PAPER OUT” LED lights up.
Explanation	<p>The error occurs in following cases.</p> <ul style="list-style-type: none"> <input type="checkbox"/> [A]: Paper is not set. <input type="checkbox"/> [B]: The printer detects end of the roll. In this time the paper feed roller holds and keeps the end of the roll. <input type="checkbox"/> [C]: The printer completed a printing on a sheet or detects end of the sheet. In this time the paper feed roller holds and keeps the end of the sheet.
Recovery	<ul style="list-style-type: none"> <input type="checkbox"/> Set paper. In the case of [B] and [C] above, remove the paper and set new paper. After setting new paper, the error will be cleared. If the printing data remains in the printer, the printing job will continue on the newly set paper. When printing job continue, the printer ejects buffer content, cuts or ejects the paper, and starts printing after developing new data. Remained data is printed and ejected with paper length designated with the command. <input type="checkbox"/> If the error is not cleared even after paper setting, Possible causes are problems with the following sensors. Take corrective action as instructed below. <ul style="list-style-type: none"> • P_REAR sensor • P_EDGE sensor <ol style="list-style-type: none"> 1. Check for paper dust or foreign matters on the sensor and clean it. 2. Check the operation of each sensor and make AD adjustment in the self-diagnostics menu. (Rear AD Adjustment (p.231) / Edge AD Adjustment (p.232)) <p>Note: Change the location of the printer if there may be an effect of any strong external light, such as the sunlight.</p>

3.2.2.2 Wrong paper source is selected on panel

Table 3-5.

Item	Description
LCD PANEL MESSAGE	LOAD xxx PAPER
LED STATUS	“PAPER OUT” LED lights up. The LED blinks corresponding to paper path set with PP command of remote command. (See Table 3-6)
Explanation	Different paper source is selected on panel from the paper source that is selected by PP command.
Recovery	Replace the paper into one that is selected by command, or the error will be also cleared by toggle the paper source setting on panel, if only the panel setting is wrong. After it is cleared, it is ready to print.

Table 3-6. LED Indications for Wrong Setting (Roll Paper/Sheet)

PP Command	Roll paper auto cut LED	Roll paper manual cut LED	Sheet LED
Roll Paper	Blink	Blink	Off
Sheet	Off	Off	Blink

3.2.2.3 Paper set lever is released during operation

Table 3-7.

Item	Description
LCD PANEL MESSAGE	SET PAPER LEVER
LED STATUS	“PAPER OUT” LED lights up.
Explanation	Paper set lever is released during operation
Recovery	It is cleared with pushing down the lever, and the printer continues the operation.

3.2.2.4 Paper set lever is released

Table 3-8.

Item	Description
LCD PANEL MESSAGE	LOWER PAPER SET LVR
LED STATUS	“PAPER OUT” LED lights up.
Explanation	Paper set lever is released during paper set operation.
Recovery	The error display will be cleared after finishing paper set and pushing down the lever, and message “PRESS PAUSE BUTTON” will appear. Refer to user's manuals for paper setting procedure.

3.2.2.5 Paper Jam

Table 3-9.

Item	Description
LCD PANEL MESSAGE	PAPER JAM
LED STATUS	“PAPER OUT” LED is blinking.
Explanation	While printing, feeding or cutting, a jammed paper prevents the CR motion. Paper jam is detected if one of rear and front paper sensor detect paper existing and over drive current or mis-synchronization of CR motor is detected.
Recovery	<input type="checkbox"/> After removing the jammed paper, “TURN PWR OFF AND ON” is displayed and then reboot by turning off and on according to the message. <input type="checkbox"/> Check the paper path for foreign matters or any deformed parts which can cause a paper jam.

Note : Errors in the drive system can occur in case of out-of-step, overcurrent or any other significant deviation from command values to the servo motor.

3.2.2.6 Front Cover Open

Table 3-10.

Item	Description
LCD PANEL MESSAGE	FRONT COVER OPEN
LED STATUS	None
Explanation	Front cover is opened. Under this error, all of CR motion and ink sequences are halted. Therefore it may give damages to printing head if this situation continues very long time.
Recovery	<input type="checkbox"/> Close the front cover. If it is happened with print ready status during printing, it recovers to print ready status automatically. If it is happened during pause, it recovers to pause status automatically. If the cover is opened during printing, the suspended printing pass is never resumed. Therefore there may appear a stripe on the printout. It is better to make the printer PAUSE by pressing the Pause button prior to open the cover while printing, however there may appear a uneven-coloring on some media because of the difference of printing time. <input type="checkbox"/> If the error is not cleared even after cover closing, Execute Checking Cover Sensor Operation in the self-diagnostics menu and if any problem is found, take corrective action. <ol style="list-style-type: none"> 1. Check that the cover is closed properly. 2. Replace the sensor.

3.2.2.7 Type-B I/F error

Table 3-11.

Item	Description
LCD PANEL MESSAGE	OPTION I/F ERROR
LED STATUS	None
Explanation	A non-supported option Type-B I/F card is installed into the printer. This error occurs when the printer is turned on.
Recovery	Turn off the printer, remove the option Type-B I/F card, and then turn on again. If the error recurs, repeat checking by installing another Type-B interface.

3.2.2.8 Paper cutting error

Table 3-12.

Item	Description
LCD PANEL MESSAGE	PAPER NOT CUT
LED STATUS	“PAPER OUT” LED is blinking.
Explanation	The paper cannot cut whole paper completely by the cutter, or cut paper remains over the front paper sensor.
Recovery	<input type="checkbox"/> Remove the cut paper, or cut manually the paper using scissors or else. User should lift the paper set lever and reset the paper or push the Pause button. Thereby the printer will execute paper initialize operation and will be printable status. In this time, if the paper is so disarranged that it may cause head friction or paper jam, user should cut the disarranged part neatly and reset the paper. User should replace the cutter blade if it becomes dull. <input type="checkbox"/> Checking the operation of the Cutter Solenoid: Execute “ Actuator 2 (p.229) ” in the self-diagnostics menu and if any problem is found, replace the actuator.

3.2.2.9 Paper Not Straight

Table 3-13.

Item	Description
LCD PANEL MESSAGE	PAPER NOT STRAIGHT
LED STATUS	“PAPER OUT” LED is blinking.
Explanation	When a skew exceed 3mm between top and end of the paper is occur, user should confirm the previous printout because it may not be printed completely. And also smudges on back of following printouts may occur because of poured ink on the platen.
Recovery	This error is cleared by paper set operation. <ul style="list-style-type: none"> • User should set the paper according the description of User's guide exactly in order to prevent the occurrence of this error. • The roll edge should be neatly arranged. • This error can be prevented at following printing by paper set operation. This error may also cleared by turning OFF→ ON, but this error may occur at following printing.

3.2.2.10 Paper check error/Paper eject error (sheet)

Table 3-14.

Item	Description
LCD PANEL MESSAGE	RELOAD PAPER
LED STATUS	“PAPER OUT” LED is blinking.
Explanation	<p>This error occur in following cases</p> <ol style="list-style-type: none"> 1. The top length of ejected paper is too long to be back-fed when paper is set. 2. Paper's horizontal position exceeds the normally printable area when paper is set. 3. Paper's horizontal position exceeds the normal cutting permission area just after printing. 4. Length of sheet exceeds the ejectable length and cannot be ejected completely. 5. After recovery of cutter error. See “3.2.2.8 Paper cutting error (p.128)”.
Recovery	<p>In case of 1,2,3, user should set the paper again according the User's guide exactly. If the top of the paper has indentation, it should be trimmed. In case of 4,5, the ejected portion of paper top should be removed and then user set paper again. User can cut the portion using auto cutter after paper set lever is lifted up (in this time, it shifts to “RELOAD PAPER”), horizontal position is reset straight, paper set lever is pushed down, roll paper auto cut is selected, and “Paper Cut/Eject” button is pushed if the paper cutting is possible.</p>

3.2.2.11 Paper is too thick for cleaning

Table 3-15.

Item	Description
LCD PANEL MESSAGE	REMOVE PAPER
LED STATUS	PAPER OUT LED is blinking.
Explanation	This error occurs when cleaning is executed although a paper thickness of with 1.2mm is set.
Recovery	Cleaning is executed automatically when paper is removed and the paper set lever is set.

3.2.2.12 Not enough ink for cleaning

Table 3-16.

Item	Description
LCD PANEL MESSAGE	NOT ENOUGH INK
LED STATUS	INK OUT LED goes on
Explanation	This error occurs when cleaning is executed although the amount of ink necessary for cleaning is not left in each ink cartridge. The amount of ink necessary differs with each cleaning. *Timer CL and others are excluded.
Recovery	This error clears automatically after about 5 seconds. Error message appears again during cleaning, unless all the installed cartridges are replaced with ones with enough ink for cleaning. The message “NOT ENOUGH INK” is displayed on the panel for 5 seconds. The corresponding “INK OUT” LED goes on for 5 seconds to alert the user to the error. The error is cleared by pressing Pause button during the 5 second period.

3.2.2.13 Ink-related Errors

- Ink End (error) : Ink end error occurs when the defined amount of ink have been consumed after NearEnd is detected. It occurs when NearEnd cartridge is inserted, whether the defined amount of ink have been consumed or not.
- No Ink Cartridge : There detected any ink cartridge slot without cartridge.
- Wrong/Non-genuine Ink Cartridge (dye / pigment):
This error occurs when wrong ink type (dye / pigment) is installed.

Table 3-17.

Item	Description
LCD PANEL MESSAGE	“INK OUT”, “NO INK CARTRIDGE” or “INVALID CARTRIDGE“
LED STATUS	Corresponding color LED lights up
Recovery	Check the CSIC contact terminal on the I/C Holder and the CSIC terminal on the ink cartridge. (damage or deformation) If no problem with the CSIC terminals is found, install a new ink cartridge.

3.2.2.14 Defective ink cartridge

Table 3-18.

Item	Description
LCD PANEL MESSAGE	INK OUT
LED STATUS	This error occurs when the ink cartridge CSIC has some problems with the contents and has loose connection. Corresponded “INK OUT” LED goes on.
Explanation	There detected some problems with the contents of the ink cartridge CSIC. Reading/writing into ink cartridge was failed.
Recovery	In case of loose connection, release the ink lever (at this time the message “SET INK” is displayed and reload the ink cartridge. When the error is not recovered, open the ink compartment, and then replace cartridge with new full one.

3.2.2.15 Ink lever released

Table 3-19.

Item	Description
LCD PANEL MESSAGE	SET INK LEVER
LED STATUS	None
Explanation	It is happen when ink lever is released.
Recovery	Set the ink lever.

3.2.2.16 Illegal ink cartridge

Table 3-20.

Item	Description
LCD PANEL MESSAGE	INVALID CARTRIDGE
LED STATUS	Corresponding color LED lights up
Explanation	This error occurs when illegal ink cartridge is installed.
Recovery	Push the Pause button.

3.2.2.17 Maintenance tank full

Table 3-21.

Item	Description
LCD PANEL MESSAGE	MAINTENANCE TANK FULL
LED STATUS	Maintenance tank LED lights up
Explanation	This error occurs when maintenance tank is full.
Recovery	Replace a maintenance tank.

3.2.2.18 No Maintenance tank

Table 3-22.

Item	Description
LCD PANEL MESSAGE	NO MAINTENANCE TANK
LED STATUS	Maintenance tank LED lights up
Explanation	This error occurs when maintenance tank is not installed properly.
Recovery	Replace a maintenance tank.

3.2.2.19 Wrong IK designation

Table 3-23.

Item	Description
LCD PANEL MESSAGE	COMMAND ERROR
LED STATUS	All color LEDs blink
Explanation	This error occurs when ink type (dye / pigment / black ink type) designated with IK command is different from ink cartridge installed in the printer, or when non-supported ESC/P3 format data is received.
Recovery	Stop data transmitting from the host and reset the panel.

3.2.2.20 Fatal Error

Table 3-24.

Item	Description
LCD PANEL MESSAGE	SERVICE REQ. nnnnnnnn nnnnnnnn indicates type of error.
LED STATUS	All color LEDs blink
Explanation	This error occurs in following cases <ul style="list-style-type: none"> • A serious failure is detected which can not fixed by users. • A life end of a unit is detected and the continuous operation may cause a more fatal problems. • Printer halted by an un-expected operation or command receiving.
Recovery	Once turn off the printer and on if the error is cleared, then user can use the printer. If the fatal error of the same code occurs again and results in impossible printer operation, find the cause of the trouble by consulting “3.2.4 Troubleshooting for Service Call Errors (p.134)” and replace the relevant defective parts.
Fatal error type	Refer to “3.2.1.3 Service Call (Fatal) Errors (p.125)”.

3.2.3 Troubleshooting for Warning

Warnings warn users the occurrences of corresponding events by replacing “READY” or “PRINTING” messages into each warning messages on LCD. But it gives no effect to any other operations. The warning messages will never cleared until the cause is resolved.

3.2.3.1 Ink Low

Table 3-25.

Item	Description
LCD PANEL MESSAGE	INK LOW
LED STATUS	Corresponding INK OUT LED blinks
Explanation	The warning occurs if CSIC detects “Near End”.
Recovery	Replace the ink cartridge with new one.

3.2.3.2 Maintenance tank full warning

Table 3-26.

Item	Description
LCD PANEL MESSAGE	MAINTENANCE TANK ALMOST FULL
LED STATUS	Maintenance tank LED blinks
Explanation	The warning occurs when the maintenance tank is almost full.
Recovery	Replace the maintenance tank with new one.

3.2.3.3 Maintenance request

- LCD PANEL MESSAGE
“MAINTENANCE REQ. nnnn”

NOTE: The code “nnnn” designates the unit to be maintained.

- Maintenance request type

The acquired value with applying exclusive OR process to bits designated as the following table is displayed on nnnn in hexadecimal form.

Table 3-27.

Bit	Request object	Cause	How to recover errors
0	Life of discharged ink tank	*	-
1	CR life	Reciprocating time of CR has reached predetermined amount.	Execute CR motor initialization in Maintenance mode 2.
2	Continue nozzle check error	*	-
3	Battery shutoff	RTC backup battery shutoff	Replace RTC backup battery.
4	White dot detector AGC error	*	-
5	Head unit	Shot time has reached predetermined amount.	Execute head unit life initialization in Maintenance mode 2.
6	Cleaning unit	Pump counter has reached predetermined amount.	Execute cleaning unit life initialization in Maintenance mode 2
7	Date is not set	Date is not set.	Set with RTC initialization in Maintenance mode 2.
8	Battery pressure	RTC backup battery pressure is low temporarily	Wait for a while
9	Reserved	-	-
:			
31	Reserved	-	-

Note : In Stylus Pro 7600/9600, Bit0, Bit2, Bit4 are also treated as Reserve.

- LED STATUS
Paper Out LED goes on at intervals of 5 seconds
- Explanation
The life of the unit that designated by the code “nnnn” is almost run out. It prompts users to call the service person to maintain it.
- Recovery
This message is cleared only when the printer is maintained by the service person.



- Maintenance requests for head unit occur at the time of 28 billion shots/nozzle.
- A cap, pump, pump motor, wiper, flushing box are replaced together when replacing the cleaning unit.

Table 3-28. “MAINTENANCE REQ nnnn” Message

	Assigned bit										nnnn	Cause	How to clear
	0	1	2	3	4	5	6	7	8	9-31			
	(NA)	1	(NA)	0	(NA)	0	0	0	0	(RSVD)	0002	CR pass count reaches the limit	Perform Maintenance Mode 2 [CLEAR COUNTERS / CR MOTOR]
	(NA)	0	(NA)	1	(NA)	0	0	0	0	(RSVD)	0008	RTC backup battery is empty	Install the battery and perform Maintenance Mode 2 [CLEAR COUNTERS / RTC]
	(NA)	0	(NA)	0	(NA)	1	0	0	0	(RSVD)	0020	The number of shots (per nozzle) reaches the limit	Perform Maintenance Mode 2 [CLEAR COUNTERS / HEAD]
	(NA)	0	(NA)	0	(NA)	0	1	0	0	(RSVD)	0040	Pump motor operation count reaches the limit	Perform Maintenance Mode 2 [CLEAR COUNTERS / CLEANER]
	(NA)	0	(NA)	0	(NA)	0	0	1	0	(RSVD)	0080	Date is not specified	Perform Maintenance Mode 2 [CLEAR COUNTERS / RTC]
	(NA)	0	(NA)	0	(NA)	0	0	0	1	(RSVD)	0100	RTC backup battery drops instantaneously	(Wait for a while) *2
ex.	(NA)	0	(NA)	1	(NA)	0	0	1	0	(RSVD)	0088	RTC backup battery is not installed	Install the battery and perform Maintenance Mode 2 [CLEAR COUNTERS / RTC]
Conditions	(Maintenance Tank life-end) *1	CR Motor - Life end	(Nozzle check error - Continue) *1	Battery empty	(Dot missing detector - AGC error) *1	Print head - Life end	Cleaning unit - Life end	Date not specified	Abnormal battery voltage	(Reserved: Not used)			

*1 Not applicable to the Stylus Pro 7600/9600.

*2 “If the same message appears again, replace the RTC backup battery and perform Maintenance Mode 2 [CLEAR COUNTERS / RTC].”

3.2.4 Troubleshooting for Service Call Errors

If any service call error has occurred, Stylus Pro 7600/9600 inhibits interruption, restores the actuators to their respective initial positions, writes the NVRAM values as a rule, and makes all the LEDs on the panel flash.

- Description:
 - Occurrence of any error from which the user can not recover the printer.
 - Life expiration of a long-life part which can cause secondary problems if the part is further used.
 - The printer has been brought into malfunction by unexpected operation or by receiving an unexpected command.
- Solution:

Turn the power off once and turn it on again. If the error display is cleared, try to continue using the printer.

If the error of the same code has occurred again, the service technician must replace the relevant part with a new one. Then the error display will be cleared.

NOTE: See “3.2.1.3 Service Call (Fatal) Errors (p.125)”.

3.2.4.1 CR motor life (00000101)

- Problem:

The number of carriage round trips has reached the specified value.
- Specified value:

Stylus Pro 9600: 2,500,000 passes (B0/Speed)
Stylus Pro 7600: 3,250,000 passes (A1/Speed)

NOTE: 1 Pass = 1 round trip
- Remedy:
 1. Replace the CR Motor and Driven Pulley.
 2. Check the Head FFC for breakage, scratches on the surface or damage.
 3. Check the ink supply tube for cracks, breakage or ink leakage.
 4. Check the CR motor life by “SelecType” (p.35).
([SelecType] key → “PRINTER STATUS MENU”
→ “SERVICE LIFE”)
 - When the life of the CR motor has been almost expired:
 - Replace the CR Motor ASSY (p.180).
 - When the CR motor has still an adequate life remaining.:
 - Replace the MAIN Board (C472 MAIN) (p.207).

CHECK
POINT



- After replacing the CR Motor, execute “Initialize CR motor life” (p83) in “Maintenance Mode 2”.
- Do not initialize the CR Motor cumulative counter value (“CR TOTAL”).

3.2.4.2 PF motor encoder check error (00010000)

- Explanation:
During initial operation at power on or during PF Motor operation, there may be a case where the encoder pulse signal can not be recognized at specified intervals. In such a case, this message is displayed and the printer stops operating.
- Cause of trouble:
Broken wire for the PF motor encoder, inverted wiring for A and B pulses, disconnected connector for the encoder or motor, or inverted wiring for the motor.
- Points to be checked:
 1. The PF Encoder and the PF Loop Scale must be free from dust and dirt or any other foreign matters.
 2. The PF Timing Belt must be free from any defects and the belt must be in proper tension.
 3. The grid roller must rotate smoothly, free from undue load.
 4. Measure the resistance value of the PF Motor (5.8 Ω).
If the PF Motor is found in short mode, replace the C472MAIN Board at the same time.
 5. Execute encoder checking by “5.2.2.4 Encoder ”(p225) in the self-diagnostics menu.
 6. All the harness must be connected properly and free from short circuit or broken wire.
- Remedy:
 - Replace the [PF Encoder Sensor ASSY \(p.186\)](#).
(Refer to [PF Encoder Sensor Installation Position Adjustment \(p.272\)](#))
 - Replace the [PF Motor \(p.185\)](#).
(Refer to [PF Timing Belt Tension Adjustment \(p.264\)](#))
 - Replace the [MAIN Board \(C472 MAIN\) \(p.207\)](#).

3.2.4.3 PF Motor out of step (00010001)

- Explanation:
During PF Motor operation, there may be a case where the encoder pulse signal within the specified range is not input within a specified period of time or the pulse width is extremely long. In such a case, the PF Motor is judged to be out-of-step, so that this message is displayed and the printer stops operating.
- Cause of trouble:
 - During paper feed operation, the error counter has reached the out-of-step pulse count.
 - Defective motor.
- Points to be checked:
 1. The PF Encoder and the PF Loop Scale must be free from dust and dirt or any other foreign matters.
 2. The PF Timing Belt must be free from any defects and the belt must be in proper tension.
 3. The grid roller must rotate smoothly, free from undue load.
 4. Measure the resistance value of the PF Motor (5.8Ω)
If the PF Motor is found in short mode, replace the C472MAIN Board at the same time.
 5. Execute encoder checking by “5.2.2.4 Encoder ”(p225) in the self-diagnostics menu.
 6. All the harness must be connected properly and free from short circuit or broken wire.
- Remedy:
 - [PF Timing Belt Tension Adjustment \(p.264\)](#)
 - Replace the [PF Motor \(p.185\)](#).
 - Replace the PF motor extension cable
 - Replace the [MAIN Board \(C472 MAIN\) \(p.207\)](#).

3.2.4.4 PF motor overcurrent (00010002)

- Explanation:
During PF Motor operation, there may be a case where an abnormal current out of the specified limits is detected in the PF Motor drive circuit on the C472MAIN Board or a current exceeding the specified value is required. In such a case, this message is displayed and the printer stops operating.
- Cause of trouble:
Hardware has detected overcurrent in the PF motor circuit.
- Points to be checked:
 1. Measure the resistance value of the PF Motor (5.8Ω)
If the PF Motor is found in short mode, replace the C472MAIN Board at the same time.
 2. By visual inspection, check the PF Loop Scale for any defect, such as damage or soiling, which can cause faulty reading by the sensor.
 3. By visual inspection, check the harness of the PF Motor for any problem causing a short circuit to the frame.
- Remedy:
 - Replace the [PF Motor \(p.185\)](#).
 - Replace the PF motor extension cable
 - Replace the [MAIN Board \(C472 MAIN\) \(p.207\)](#).

3.2.4.5 PF motor in-position time out (00010003)

- Explanation:
At PF stop processing in PF Motor control, there may be a case where the paper can not move to the final target position within a specified period of time. In such a case, this message is displayed and the printer stops operating.
- Cause of trouble:
There are pulses smaller than out-of-step pulse remaining without completing paper feed.
- Points to be checked:
 1. The PF Encoder and the PF Loop Scale must be free from dust and dirt or any other foreign matters.
 2. The PF Timing Belt must be free from any defects and the belt must be in proper tension.
 3. The grid roller must rotate smoothly, free from undue load.
 4. Measure the resistance value of the PF Motor (5.8Ω)
If the PF Motor is found in short mode, replace the C472MAIN Board at the same time.
 5. Execute encoder checking by “[5.2.2.4 Encoder](#)”(p225) in the self-diagnostics menu.
 6. All the harness must be connected properly and free from short circuit or broken wire.
- Remedy:
 - Replace the [PF Encoder Sensor ASSY \(p.186\)](#).
(Refer to [PF Encoder Sensor Installation Position Adjustment \(p.272\)](#))
 - Replace the [PF Motor \(p.185\)](#).
(Refer to [PF Timing Belt Tension Adjustment \(p.264\)](#))
 - Replace the [MAIN Board \(C472 MAIN\) \(p.207\)](#).
 - Replace the PF motor extension cable

3.2.4.6 CR motor encoder check error (00010004)

- Explanation:
During initial operation at power on or during CR Motor operation, there may be a case where the encoder pulse signal is not input at specified intervals. In such a case, this message is displayed and the printer stops operating.
- Cause of trouble:
Broken wire for the CR motor encoder, inverted wiring for A and B pulses, disconnected connector for the encoder or motor, or inverted wiring for the motor.
- Points to be checked:
 1. The CR Encoder and the T Fence must be free from dust and dirt or any other foreign matters.
 2. The CR Timing Belt must be free from any defects and the belt must be in proper tension.
 3. The carriage must slide smoothly, free from undue load.
 4. Measure the resistance value of the CR Motor. (5.8Ω)
 5. Execute encoder checking by “5.2.2.4 Encoder”(p225) in the self-diagnostics menu.
 6. All the harness must be connected properly and free from short circuit or broken wire.
- Remedy:
 - Replace the CR Encoder Sensor ASSY (p.178).
(Refer to “CR Encoder Sensor Mounting Position Adjustment” (p.268))
 - Replace the CR Motor ASSY (p.180).
(Refer to “CR Timing Belt Tension Adjustment” (p.263))
 - Replace the MAIN Board (C472 MAIN) (p.207).
 - Check to see if the timing fence for detection of the encoder pulse is removed
 - Check for dirt, paper dust or damage to the timing fence

3.2.4.7 CR motor out of step (00010005)

- Explanation:
During CR Motor operation, there may be a case where the encoder pulse signal within the specified range is not input within a specified period of time or the pulse width is extremely long. In such a case, the CR Motor is judged to be out-of-step, so that this message is displayed and the printer stops operating.
- Cause of trouble:
 - The error counter has reached the out-of-step pulse count because of impossible movement of the carriage, bumping of the carriage or dirty timing fence.
 - Defective motor.
- Points to be checked:
 1. The CR Encoder and the T Fence must be free from dust and dirt or any other foreign matters.
 2. The CR Timing Belt must be free from any defects and the belt must be in proper tension.
 3. The carriage must slide smoothly, free from undue load.
 4. Measure the resistance value of the CR Motor. (5.8Ω)
 5. Execute encoder checking by “5.2.2.4 Encoder”(p225) in the self-diagnostics menu.
 6. All the harness must be connected properly and free from short circuit or broken wire.
 7. Check the carriage home position sensor.
- Remedy:
 - Replace the CR Motor ASSY (p.180).
(Refer to “CR Timing Belt Tension Adjustment” (p.263))
 - Replace the MAIN Board (C472 MAIN) (p.207).
 - Replace the CR_HP Sensor ASSY (p.183).
 - Replace the CR Encoder Sensor ASSY (p.178).
(Refer to “CR Encoder Sensor Mounting Position Adjustment” (p.268))
 - Replace the CR Encoder Scale (Timing Fence) (p.184).
 - Check to see if the timing fence for detection of the encoder pulse is not installed correctly.
 - Check for dirt, paper dust or damage to the timing fence

3.2.4.8 CR motor overcurrent (00010006)

- Explanation:
During CR Motor operation, there may be a case where an abnormal current out of the specified limits is detected in the CR Motor drive circuit on the C472MAIN Board or a current exceeding the specified value is required. In such a case, this message is displayed and the printer stops operating.
- Cause of trouble:
Hardware has detected overcurrent in the CR motor circuit.
- Points to be checked:
 1. Measure the resistance value of the CR Motor. (5.8Ω)
If the CR Motor is found in short mode, replace the C472MAIN Board at the same time.
 2. By visual inspection, check the T Fence for any defect, such as damage or soiling, which can cause faulty reading by the sensor.
 3. By visual inspection, check the harness of the CR Motor for any problem causing a short circuit to the frame.
- Remedy:
 - Replace the [MAIN Board \(C472 MAIN\)](#) (p.207).
 - Replace the [CR Motor ASSY](#) (p.180).
(Refer to “[CR Timing Belt Tension Adjustment](#)” (p.263))
 - Correct the carriage home position.
 - Remove the foreign matters. Clean the timing fence.

3.2.4.9 CR motor in-position time-out (00010007)

- Explanation:
At carriage stop processing in CR Motor control, there may be a case where the carriage can not move to the final target position within a specified period of time (as per pulse detection). In such a case, this message is displayed and the printer stops operating.
- Cause of trouble:
There are pulses smaller than out-of-step pulse remaining without completing paper feed.
- Points to be checked:
 1. The CR Encoder and the T Fence must be free from dust and dirt or any other foreign matters.
 2. The CR Timing Belt must be free from any defects and the belt must be in proper tension.
 3. The carriage must slide smoothly, free from undue load.
 4. Measure the resistance value of the CR Motor. (5.8Ω)
 5. Execute encoder checking by “[5.2.2.4 Encoder](#)” (p225) in the self-diagnostics menu.
 6. All the harness must be connected properly and free from short circuit or broken wire.
- Remedy:
 - Replace the [CR Encoder Sensor ASSY](#) (p.178).
(Refer to “[CR Encoder Sensor Mounting Position Adjustment](#)” (p.268))
 - Replace the [CR Motor ASSY](#) (p.180).
(Refer to “[CR Timing Belt Tension Adjustment](#)” (p.263))
 - Replace the [MAIN Board \(C472 MAIN\)](#) (p.207).
 - Replace the [CR_HP Sensor ASSY](#) (p.183).

3.2.4.10 Servo interrupt watchdog time-out (00010008)

- Explanation:
During the CR Motor or PF Motor operation, there may be a case where watch dog time-out is detected in the DC motor control circuit or on the ASIC. In such a case, this message is displayed and the printer stops operating.
- Cause of trouble:
System trouble.
- Remedy:
Since the cause is deemed to be a defective CPU or ASIC, replace the [MAIN Board \(C472 MAIN\) \(p.207\)](#).

3.2.4.11 System interrupt watchdog time-out (00010009)

- Explanation:
In the data processing stage on the C472MAIN Board, there may be a case where runaway or defective cash occurs on CPU or ASIC. In such a case, this message is displayed and the printer stops operating.
- Cause of trouble:
System trouble.
- Remedy:
Since the CPU or ASIC is deemed defective, take the following action:

If this error is not cleared even when the power is turned off once and on again, replace the [MAIN Board \(C472 MAIN\) \(p.207\)](#).

3.2.4.12 CR home position sensor error (0001000A)

- Explanation:
During initial operation at power on or during printing operation, there may be a case where the home position can not be detected at the home position detection timing or within a specified period of time. In such a case, this message is displayed and the printer stops operating.
- Cause of trouble:
Shield plate detection error due to no change in the signal from the CR home position sensor.
- Points to be checked:
 1. Check that the sensor functions properly.
(Refer to “5.2.2.3 Sensors ”(p224) in the self-diagnostics menu.)
 2. Check that the sensor is free from adhesion of any foreign matters.
- Remedy:
 - Replace the [CR_HP Sensor ASSY \(p.183\)](#).
 - Replace the [MAIN Board \(C472 MAIN\) \(p.207\)](#).

3.2.4.13 PF home position sensor error (0001000B)

Does not occur (there is no function to detect PF home position).

3.2.4.14 Head slide (PG) home position sensor error (0001000C)

- Explanation:
During initial operation at power on or during head platen gap fluctuation (change) operation after paper setting, there may be a case where the head slide home position can not be detected. In such a case, this message is displayed and the printer stops operating.
- Cause of trouble:
 - Home position detection error due to head slide out-of-step
 - Defective head slide home position sensor
 - Defective head slide motor, disconnected connector or broken cable
 - Gears not engaged properly
- Points to be checked:
 - Head Slide Detection Sensor
 - Check that the sensor functions properly.
 - Check that the sensor and the head platen gap drive gear are free from obstruction by adhesion of foreign matters or soiling.
 - Head Slide Motor (Pump Motor)
 - Measure the resistance value. (9.2Ω)
If the motor is found in short mode, replace the C472MAIN Board at the same time.
 - Check that the motor operates properly.
(Refer to “5.2.2.4 Encoder ”(p.225) in the self-diagnostics menu.)
 - Check that the gear train including the head platen gap drive gear is free from any obstruction.
- Remedy:
 - Replace the [HEAD_SLIDE Sensor ASSY \(p.182\)](#).
 - Replace the [Pump Motor ASSY \(p.200\)](#).

NOTE: Refer to “[Head Slide \(PG Change\) Initialization Sequence](#)” (p.107).

3.2.4.15 CR motor PWM output faulty (0001000F)

- Explanation:
There may be a case where a current exceeding the specified value flows during CR Motor operation. In such a case, this message is displayed and the printer stops operating.
This error can be displayed in the following case: an abnormal load which does not reach the level causing an out-of-step phenomenon 00010005 in the carriage drive system has occurred and the running speed of the motor has been detected to be too low, so that the current is increased to raise the running speed of the motor. Thus, this message appears to prevent the CR Motor from being overheated.
- Cause of trouble:
 - A small PWM output is kept on for a certain period of time (load is kept applied).
 - Carriage related mechanism out of step or carriage bumped.
- Remedy/Points to be checked:
 1. Check the load on the CR Motor.
 - Running load of CR Motor (check by manual operation)
 - Measure the resistance value of the CR Motor.(5.8Ω)
 - Damage to or wear in the CR Driven Pulley
 - Damaged or worn bearing of the CR Unit
 - Flaws in the CR Rail caused by roller running
 - Tension of the steel belt
 2. Replace the [CR Motor ASSY \(p.180\)](#).
If the CR Motor is found in short mode, replace the C472MAIN Board at the same time.
 3. Replace the [MAIN Board \(C472 MAIN\) \(p.207\)](#).

3.2.4.16 PF motor PWM output faulty (00010010)

Explanation:

There may be a case where a current exceeding the specified value flows during PF Motor operation. In such a case, this message is displayed and the printer stops operating.

This error can be displayed in the following case: an abnormal load which does not reach the level causing an out-of-step phenomenon 00010001 in the paper feed drive system has occurred and the running speed of the motor has been detected to be too low, so that the current is increased to raise the running speed of the motor. Thus, this message appears to prevent the PF Motor from being overheated.

Cause of trouble:

- A small PWM output is kept on for a certain period of time (load is kept applied).
- Paper feed related mechanism out of step.

Remedy/Points to be checked:

1. Check the load on the PF Motor.
 - Measure the resistance value of the PF Motor (5.8Ω)
If the PF Motor is found in short mode, replace the C472MAIN Board at the same time.
 - Running load of PF Motor (check by manual operation)
 - Rotation load of PF Roller
2. Replace the [PF Motor \(p.185\)](#).
3. Replace the [MAIN Board \(C472 MAIN\) \(p.207\)](#).

3.2.4.17 Head driver (TG) temperature error (0001001B)

Explanation:

During printing operation, there may be a case where the temperature inside the print head has risen above the specified value and the thermistor in the print head detects it as abnormal temperature. In such a case, this message is displayed and the printer stops operating.

Cause of trouble:

- Head broken down.
- Faulty contact of tape electric wire, broken wire or wire out of position.

Remedy:

1. Turn off the power to the printer once and turn it on again and check for recovery.
2. If the same error occurs immediately or in a short time, replace the print head with a new one.

3.2.4.18 CR servo parameter error (0001001D)

- Explanation:
There may be a case where a voltage exceeding the specified value is about to be applied to the CR Motor. In such a case, this message is displayed and the printer stops operating.
- Cause of trouble:
 - A small PWM output is kept on for a certain period of time (load is kept applied).
 - Carriage related mechanism out of step or carriage bumped.
- Points to be checked:
 1. The CR Encoder and the T Fence must be free from dust and dirt or any other foreign matters.
 2. The CR Timing Belt must be free from any defects and the belt must be in proper tension.
 3. The carriage must slide smoothly, free from undue load.
 4. Measure the resistance value of the CR Motor.(5.8Ω)
If the CR Motor is found in short mode, replace the C472MAIN Board at the same time.
 5. Execute encoder checking by “5.2.2.4 Encoder ”(p225) in the self-diagnostics menu.
 6. All the harness must be connected properly and free from short circuit or broken wire.
- Remedy:
 - Replace the MAIN Board (C472 MAIN) (p.207).
 - Replace the CR Encoder Sensor ASSY (p.178).
(Refer to “CR Encoder Sensor Mounting Position Adjustment” (p.268))
 - Replace the CR Motor ASSY (p.180).
(Refer to “CR Timing Belt Tension Adjustment” (p.263))
 - Make the mechanism adjustment for the carriage-related mechanism.
 - Remove the foreign matters.

3.2.4.19 PF servo parameter error (0001001E)

- Explanation:
There may be a case where a voltage exceeding the specified value is about to be applied to the PF Motor. In such a case, this message is displayed and the printer stops operating.
- Cause of trouble:
 - A small PWM output is kept on for a certain period of time (load is kept applied).
 - Paper feed related mechanism out of step.
- Points to be checked:
 1. The PF Encoder and the PF Loop Scale must be free from dust and dirt or any other foreign matters.
 2. The PF Timing Belt must be free from any defects and the belt must be in proper tension.
 3. The grid roller must rotate smoothly, free from undue load.
 4. Measure the resistance value of the CR Motor.(5.8Ω)
If the CR Motor is found in short mode, replace the C472MAIN Board at the same time.
 5. Execute encoder checking by “5.2.2.4 Encoder ”(p225) in the self-diagnostics menu.
 6. All the harness must be connected properly and free from short circuit or broken wire.
- Remedy:
 - Replace the MAIN Board (C472 MAIN) (p.207).
 - Replace the PF Encoder Sensor ASSY (p.186).
(Refer to PF Encoder Sensor Installation Position Adjustment (p.272))
 - Replace the PF Motor (p.185).
(Refer to PF Timing Belt Tension Adjustment (p.264))
 - Clear the cause of paper feed related mechanism out-of-step.

3.2.4.20 CSIC reed/right error (00010020)

- Explanation:
At turning on or off the power, at opening or closing the I/C Cover or at completion of one-page printing, there may be a case where it is impossible to read the data from the CSIC of the ink cartridge or write the latest ink information in the CSIC. In such a case, this message is displayed and the printer stops operating.
- Cause of trouble:
Read/write for CSIC (ink cartridge) is impossible.
- Remedy:
 - Faulty contact with the CSIC
(Deformation of the CSIC contact connector / Replace the Holder Assembly IC.)
 - Defective CSIC Board (Replace the ink cartridge.)
 - Replace the CSIC Board (ink cartridge).
 - Tape electric wire out of position
 - Replace the supply valve unit. (Faulty contact with the CSIC)
 - Replace the [C472_SUB-B Board \(p.192\)](#).
 - Replace the [MAIN Board \(C472 MAIN\) \(p.207\)](#).

3.2.4.21 Ink type error (setting on printer body side) (00010022)

- Cause of trouble:
 - An ink type other than dye/pigment has been set.
 - “Ink type: neutral” setting with “CSIC detection: OFF” setting.
- Remedy:
 - Install the correct cartridge.
 - With the ink lever released, set “ink type” in “[Maintenance Mode 2](#)” (p.70).
NOTE: If setting is performed with the ink lever in the set position, initialization will start again and the service call error will occur again.

3.2.4.22 RTC analysis error (00010023)

- Explanation:
There may be a case where the absolute time data stored on NVRAM indicates an impossible date or hour. In such a case, this message is displayed and the printer stops operating.
- Cause of trouble:
Various values of the absolute time data stored in NVRAM are abnormal.
- Remedy:
 - [Initialize RTC \(p.83\)](#)
 1. With the paper set lever in the up position, start “[Maintenance Mode 2](#)” (p.70).
(Power OFF→ [Paper Source] + [Cut/Eject] + [Paper Feed ▽] → Power ON)
 2. Input a date and hour in “Initialize RTC” in the counter initialize menu and turn off the power.
(“CLEAR COUNTERS”→ “RTC”)
 - Remove the lithium battery once and install it again.
 - Replace the lithium battery with a new one.
 - Replace the [MAIN Board \(C472 MAIN\) \(p.207\)](#).

3.2.4.23 CSIC ROM communication error (00010025)

- Explanation:
Only when the starter cartridge is used, there may be a case where an error occurs in communication with the CSIC and Main Board. In such a case, this message is displayed and the printer stops operating.
- Cause of trouble:
Faulty contact of ink cartridge
(Only with the starter cartridge or with individual cartridges for which writing has been performed by the factory setting command.)
- Remedy:
Make sure that the ink cartridge is connected properly.

3.2.4.24 RTC communication error (00010026)

- Explanation:
There may be a case where the RTC circuit on the Main Board operates incorrectly. In such a case, this message is displayed and the printer stops operating.
- Cause of trouble:
The RTC on the circuit board is operating abnormally (operating in test mode).
- Remedy:
 1. Remove the battery once with the power turned off and after waiting for a while, install the battery again and turn the power on.
 2. Repeat step 1 above until this error does not occur at power-on.
 3. After making certain that the error does not occur, set the date and hour for the RTC by [Initialize RTC \(p.83\)](#) in “[Maintenance Mode 2](#)” ([p.70](#)) or by booting the printer in the normal mode and sending the timer IC value change command of the factory setting commands.

3.2.4.25 Head error (00010028)

- Cause of trouble:
The head is damaged.
- Remedy:
 - Replace the [Print Head \(p.171\)](#).

3.2.4.26 Unidentified NMI (00010029)

- Cause of trouble:
CPU has detected undefined NMI.
- Remedy:
If this error is not cleared even when the power is turned off once and on again, replace the [MAIN Board \(C472 MAIN\) \(p.207\)](#).

3.2.4.27 CR ASIC ECU error (0001002A)

- Cause of trouble:
Faulty firmware or damaged drive circuit board
- Remedy:
 - [Firmware Reinstallation \(p.219\)](#)
 - Replace the [MAIN Board \(C472 MAIN\) \(p.207\)](#).

3.2.4.28 PF ASIC ECU error (0001002B)

- Cause of trouble:
Faulty firmware or damaged drive circuit board
- Remedy:
 - [Firmware Reinstallation \(p.219\)](#)
 - Replace the [MAIN Board \(C472 MAIN\) \(p.207\)](#).

3.2.4.29 NVRAM error (00020000)

- Explanation:
There may be a case where the parameter data in NVRAM is broken. In such a case, this message is displayed and the printer stops operating.
- Cause of trouble:
NVRAM erase error or write error (Check in 2 bytes)
- Remedy:
 - Download the parameter data from another model.
(However, make the necessary adjustments.)
 - Replace the [MAIN Board \(C472 MAIN\) \(p.207\)](#).

3.2.4.30 SDRAM error (00020002)

- Explanation:
In memory check of SDRAM executed at power on, there may be a case where a bit error is detected. In such a case, this message is displayed and the printer stops operating.
- Cause of trouble:
SDRAM check error at power-on.
- Remedy:
 - Replace the [MAIN Board \(C472 MAIN\) \(p.207\)](#).

3.2.4.31 BOOT program SUM error (00020003)

- Explanation:
There may be a case where the boot program of firmware is broken. In such a case, this message is displayed and the printer stops operating. (Only at power on)
- Cause of trouble:
SUM check error for BOOT program area.
- Remedy:
 - [Firmware Reinstallation \(p.219\)](#)
 - Replace the [MAIN Board \(C472 MAIN\) \(p.207\)](#).

3.2.4.32 Flash memory SUM error (00020009)

- Explanation:
This error is displayed when the firmware has not been installed in flash memory or when the firmware has not been installed successfully.
- Cause of trouble:
SUM check error for program area.
- Remedy:
 - [Firmware Reinstallation \(p.219\)](#)
 - Replace the [MAIN Board \(C472 MAIN\) \(p.207\)](#).

3.2.4.33 Program load error (0002000A)

- Cause of trouble:
SUM check error for program area on RAM.
- Remedy:
 - [Firmware Reinstallation \(p.219\)](#)
 - Replace the [MAIN Board \(C472 MAIN\) \(p.207\)](#).

3.2.4.34 Internal memory shortage error (0002000B)

- Explanation:
This error appears when the cash area is insufficient. There may be a case where the assigned work area varies with the I/F mode and I/F mode setting does not agree or decoding of a command is impossible. Then the work area is consumed up, thus memory runs short. In such a case, this message is displayed and the printer stops operating.
- Cause of trouble:
Faulty program.
- Remedy:
 - [Firmware Reinstallation \(p.219\)](#)
 - Check I/F mode.
 - Replace the [MAIN Board \(C472 MAIN\) \(p.207\)](#).

3.2.4.35 Review error (0002000C)

- Explanation:
There may be a case where the combination of the DIP Switch setting positions on the Main Board is not supported by the firmware. In such a case, this message is displayed and the printer stops operating.
- Cause of trouble:
Driver circuit board review and the state of the DIP switch are not consistent with the program version.
- Remedy:
 - Check driver circuit board review and state of DIP switch.
 - Check the DIP Switch setting. (*See p.209*)

3.2.4.36 CPU address error (load misalignment) (100000E0)

- Cause of trouble:
Defective circuit board or faulty CPU soldering. Program trouble or generation error.
- Remedy:
 - [Firmware Reinstallation \(p.219\)](#)
 - Replace the [MAIN Board \(C472 MAIN\) \(p.207\)](#).

3.2.4.37 CPU address error (storage misalignment) (10000100)

- Cause of trouble:
Defective circuit board or faulty CPU soldering. Program trouble or generation error.
- Remedy:
 - [Firmware Reinstallation \(p.219\)](#)
 - Replace the [MAIN Board \(C472 MAIN\) \(p.207\)](#).

3.2.4.38 CPU reserve command code exception error (10000180)

- Cause of trouble:
Defective circuit board or faulty CPU soldering. Program trouble or generation error.

- Remedy:
 - [Firmware Reinstallation \(p.219\)](#)
 - Replace the [MAIN Board \(C472 MAIN\) \(p.207\)](#).

3.2.4.39 CPU slot illegal command exception error (100001A0)

- Cause of trouble:
Faulty CPU soldering. Program trouble or generation error.
- Remedy:
 - [Firmware Reinstallation \(p.219\)](#)
 - Replace the [MAIN Board \(C472 MAIN\) \(p.207\)](#).

3.2.4.40 CPU DMA address error (100005C0)

- Cause of trouble:
Defective circuit board or faulty CPU soldering. Program trouble or generation error.
- Remedy:
 - [Firmware Reinstallation \(p.219\)](#)
 - Replace the [MAIN Board \(C472 MAIN\) \(p.207\)](#).

3.2.4.41 CPU error (10000xxx)

- Cause of trouble:
Defective circuit board or faulty CPU soldering. Program trouble or generation error.
- Remedy:
 - [Firmware Reinstallation \(p.219\)](#)
 - Replace the [MAIN Board \(C472 MAIN\) \(p.207\)](#).

3.3 Troubleshooting Based on Your Printout

This section describes conceivable print quality problems that may occur with this printer and the troubleshooting points for those errors.

Table 3-29. Diagnosing trouble based on printout

Item	Description	Refer to
1	Dot missing	p.147
2	Uneven printing/poor resolution	p.148
3	Smudged or marred printout on front side	p.148
4	Smudged or marred printout on reverse side	p.149
5	White/black banding	p.149

3.3.1 Dot Missing

If the printer is kept for a long time without being used, the viscosity of the ink on the nozzle surfaces of the print heads, and in the nozzles themselves, increases, and may cause skipping of dots during printing. In such cases, execute [Power cleaning \(p.60\)](#) in SelecType mode first (execute several times). If normal printing is not recovered even after this power cleaning, check the following particulars.

- Execute powerful cleaning of the ink head.
 1. Execute Initial filling ([p.259](#)) or [KK2] cleaning.
Execute “Initial charge or [KK2]” in the [Cleaning \(p.259\)](#) menu of [Self-diagnostic Function \(p.220\)](#).
(Power OFF→[Paper Feed Δ]+[Paper Feed ▽]+[Cut/Eject] →Power ON) → “Cleaning” → “Init.Fill”
 2. [Nozzle Check Pattern Printing \(p.45\)](#)
Execute “Nozzle Check Pattern Printing” in the SelecType menu.
([SelecType] → “TEST PRINT MENU” → “NOZZLE CHECK”)

CHECK
POINT



In initial filling, a large amount of ink will be discharged into the Maintenance Tank. Therefore, check the counter indication (remaining value) beforehand. (If deemed necessary, prepare another Maintenance Tank as a spare.)

- The actions above do not work to recover the printer, check the following points:
 - If trouble occurs in all the ink colors:
 - Are the print heads and cap assemblies sealed during ink filling?
 - If the cap assembly / pump tubes have come off.
 - If the life of the cleaning unit has expired.
 - If the gear train between the pump motor and pump unit has been assembled improperly.
 - If the cap assembly has failed.
(The tension spring has come off, the cap rubber is damaged, etc.)
 - If the pump unit has failed.
(The tubes are crushed, etc.)
 - If the trouble occurs with a specific ink color:
 - Abnormal connections between the ink cartridge, ink holder, tube, damper, print head.
(Fastening nuts loose, or the O-ring deformed or damaged, causing ink to leak, etc. could occur.)
 - Print head failure
 - If the trouble still has not been recovered from with the items up to this point, replace the following electric system related parts and check again.
 - Check the connections to the CR cable (FFC long) and if there is any damage to it or not.
 - Check the connections to the head cables (FFC short; x 2), and if there is any damage to them or not.
 - MAIN Board

CAUTION



■ If you replace the MAIN board or the print heads, the connection state of the connection cables (FFC) should be checked. Particularly in cases where the connector is inserted at a slant, etc., when the power is turned on, it could cause destruction of the circuit and the insides of the heads, so sufficient caution should be exercised.

3.3.2 Uneven Printing/Poor Resolution

If the print quality is abnormal (uneven printing, diffused image, etc.), the following items should be checked.

1. Adjust the gap
In the [SelecType \(p.35\)](#) or the [Self-diagnostic Function \(p.220\)](#) menu, carry out gap adjustment (“[Gap Adjustment \(Bi-D Adjustment, Uni-D Adjustment\) \(p.60\)](#)” and “[Round Trip Print Position Adjustment \(Bi-D Adjustment\) \(p.248\)](#)”).
2. If the trouble occurs only when the user is using a specific type of paper (thick paper), carry out “User Paper Setting” using the panel setting procedure.
(By setting the information concerning the thickness of the paper the user is using and correcting the print position (correction of changes in the position where ink hits the paper surface due to differences in paper thickness), avoid influencing the print position.)
3. If the this problem occurs after replacing the Main Board with a new one:
 - Transfer the backup parameters on the old Main Board to the new board. ([p.219](#))
 - Execute “Write D/A Correction Values” in the diagnostic mode. ([p.236](#))
4. If the printer's condition is not improved by the above items (adjustments), check the following items using the self-diagnostic function.
 - [Head Slant Checking \(p.246\)](#)

CHECK
POINT



Once you have made the “Head Slant Adjustment”, be sure to make the “[Round Trip Print Position Adjustment \(Bi-D Adjustment\) \(p.248\)](#)” and “[Gap Adjustment \(Bi-D Adjustment, Uni-D Adjustment\) \(p.60\)](#)”.

3.3.3 Smudged or Marred Printout (Front)

If smudging or marring occurs due to rubbing by the head, etc. on the paper's printed surface, check the following items.

1. If smudging is occurring at the front end of the roll paper or at the rear end, widen the margins at the front end and rear end. (Set the “Roll Paper Margin” front end and rear end on “15 mm”.)
(If high duty printing was done close to the front end and rear end (margin = 3 mm), the paper will contain a large amount of ink and deformation of the paper will be accelerated, and depending on the case, the paper will touch the heads.)
2. If paper with weak edges which cannot move smoothly along the paper path is being used, Select “NORM” for “SUCTION” in the “PAPER CONFIG. MENU”, which is in the “Panel Settings”.
3. If there is rubbing and smudging due to slow drying in printing of user paper.
 - Set the stand basket paper Eject direction on Front.
 - In the item “DRYING TIME” in the User Paper Setting Menu”, in “Panel Settings,” set the drying time (the time until auto paper cutting is carried out after printing is finished. (Default: 0 second; Maximum: 10 seconds)
4. If the trouble cannot be resolved by the above methods, check the following.
 - The cap assembly / tension spring is off.
(If this spring comes off, cap will collect inside the cap and ink that adheres around the head nozzle surface ends up adhering to the paper.
 - Check to see if dust containing ink, foreign matters or paper is adhering to the side surface of the head.

3.3.4 Smudged or Marred Printout (Reverse side)

If smudging or marring of the paper back surface with ink occurs, the following items should be checked.

1. Check to see if there isn't ink adhering to the paper feed path. If there is ink adhering, it should be wiped off.
 - Sub-platen A/B Surface
 - Grid roller surface
 - Paper guide L surface
 - Paper guide L2 surface
2. One likely cause of ink adhering to the above parts is the following cause.
 - Paper feeding at a slant during printing (at the point when 1 page is finished)
 - The ink absorbing sponge for "borderless printing" is deformed or swelling.

CAUTION



If the Paper Skew Detection setting is off in "Printer Settings" → "Panel Setting Menu" → "Paper Width Detection," if the user's paper size setting is not correct, the surface of the platen will be printed.

3.3.5 White or Black Banding in the carriage running direction

If white or black banding (uneven density) in parallel with the carriage running direction appears on your printout, check the following points:

1. [Nozzle Check Pattern Printing \(p.45\)](#)
 Select "Adj: Check Nozzle" in the [Adjustment \(p.230\)](#) menu by the self-diagnostic function.
 Check the following points:
 - Dot missing
 - Head ID setting value

If dot missing is found, execute head cleaning. (If deemed necessary, select and execute "[Power cleaning \(p.60\)](#)" in the SelecType mode or "[Cleaning \(p.259\)](#)" by self-diagnostic function.) If the Head ID value is wrong, set the correct value.
2. Adjustment
 If dot missing is not found, perform the following adjustments and check for improvement:
 - Paper feed correction (driver)
 - [Head Slant Adjustment \(Mechanical Adjustment\) \(p.247\)](#)
 If each line of nozzles in the head is perpendicular to the carriage running direction correctly, the raster lines printed with nozzles can overlap or be dislocated, so that black banding (uneven density) or white banding (blank spaces between raster lines) may occur.

If the adjustments above do not work enough to improve the quality, try to improve by executing [Feed Correction + T&B Adjustment \(p.239\)](#) by the self-diagnostic function.

3.3.6 Banding in the paper feed direction

If banding (uneven density, rough image) in parallel with the paper feed direction is found on the print, perform the following adjustment:

Bi-D adjustment:

The Bi-D adjustment can be executed by any of the following methods.

- “Gap Adjustment” in the panel setting menu
- Adjustment by printer driver

If the adjustment above does not work to improve the print quality, you may improve it by adjusting the “Paper thickness” setting value ($\pm 0.1 \sim 0.2$ mm) in “User Paper Setting Menu” of the panel setting menu.

CHAPTER

4

DISASSEMBLY & ASSEMBLY

4.1 Summary

This Chapter describes the disassembly and reassembly procedure chiefly for Stylus Pro 7600, with descriptions added to particulars specific to Stylus Pro 9600. Unless otherwise specified, disassembled units or components can be reassembled by reversing the disassembly procedure.

Things, if not strictly observed, that could result in injury or loss of life are described under the heading “Warning”.

Precautions for any disassembly or assembly procedures are described under the heading “CAUTION”.

Chips for disassembling procedures are described under the heading “CHECK POINT”.

If the assembling procedure is different from the reversed procedure of the disassembling, the procedure is described under the heading “REASSEMBLY”.

Any adjustments required after disassembling the units are described under the heading “ADJUSTMENT REQUIRED”. Be sure to make the specified adjustments by referring to Chapter 5 “ADJUSTMENT”.

When you have to remove any units or parts that are not described in this chapter, refer to the exploded diagrams in the appendix.

4.1.1 Precautions

Before proceeding with any disassembly or assembly work, make absolutely sure of the following.



- The power switch for Stylus Pro 7600/9600 is incorporated in the secondary circuit of the power supply circuit. Therefore, the printer is always supplied with electric power, unless the power cable is disconnected. Before servicing, unless otherwise stated, be sure to unplug the power cord from the wall outlet to prevent injury, burn, and electric shocks or damage to the circuit. In doing so, be sure to turn the printer off and wait several seconds first and then unplug the power cord. If you must keep the power supplied to measure voltage, be aware of the potential for electrical shock and do all tasks with the most care.
- With the front cover open, the cover sensor stops the operation of the CR motor and PF motor. To ensure safety, you are prohibited from disabling this interlock function.
- A lithium battery for memory backup is installed on the main circuit board of Stylus Pro 7600/9600. To prevent accidents caused by the battery, never fail to observe the following instructions when serving the main circuit board:
 - Keep the battery away from any metal or other batteries so that electrodes of the opposite polarity do not come in contact with each other.
 - Do not solder on any part of the battery. (Doing so may result in leakage of electrolyte from the battery, burning or explosion. The leakage may affect other devices close to the battery.)
 - Do not charge the battery. (This may cause burning or explosion.)
 - Do not dismantle the battery. (The gas inside the battery may hurt your throat. Leakage, burning or explosion may also be caused.)
 - Do not short-circuit the terminals of the battery. Do not put the battery on a conductive table in such a way that the terminal face comes in contact with the table.
 - Do not remove and install the battery. Do not install the battery in the wrong direction.
 - Do not heat the battery or put it near fire.



- Danger of explosion if the battery is incorrectly replaced. Replace only with the same or equivalent type recommended by the manufacture. Dispose the used batteries according to government's law and regulations.
- Wear protective goggles to protect your eyes from ink. If ink gets in your eye, flush the eye with fresh water and see a doctor immediately.
- Wear a pair of gloves to protect your hands from the sharp edge in the printer mechanism.
- If ink comes into contact with your skin, wash it off with soap and water. If irritation occurs, contact a physician.



- Avant de commencer, assurez vous que l'imprimante soit éteinte et que le cordon d'alimentation soit débranché.
- Lorsque vous changez la pile au lithium, assurez vous que la nouvelle respecte bien les caractéristiques requises.
- Lorsque que vous installez la pile au lithium, faites attention à l'insérer dans le bon sens en respectant la polarité.
- Veuillez à jeter les piles usagées selon le règlement local.
- Ne rechargez pas les piles au lithium.



- Risque d'explosion si la pile est remplacée incorrectement. Ne remplacer que par une pile du même type ou d'un type équivalent recommandé par le fabricant. Éliminer les piles déchargées selon les lois et les règles de sécurité en vigueur.



- Before servicing or performing maintenance on the printer, make sure you have enough space. If you need to move the printer, make sure the space you move to is safe.
- Because the printer is much heavier than most printers you need to take extra care. If you need to take apart the printer and the stand from each other or put them together, two people are necessary.
- If you remove and replace any parts of the ink path system, be sure to discharge the ink beforehand by executing "Ink Blowing" in "Clean Head" process. Refer to "5.2.3.20 Clean Head (p.256)".
- After removing any of the ink related parts, double check to make sure all parts are secured; otherwise you're going to be in big trouble.
- Use only recommended tools for disassembling, assembling or adjusting the printer.
- Apply lubricants and adhesives as specified.
- Ink may leak onto other printer parts or the printer basket when removing printer parts, so it is recommended to put a sheet or cloth under the printer, especially when working on or near ink-related parts.
- When working on the electrical circuit boards, be careful concerning static electricity which can cause damage to the board. It is recommended you use an anti-static wrist band or similar grounding device to prevent static electricity buildup.
- Stylus Pro 7600/9600 uses many FFCs (Flexible Flat Cables). Improper connection, such as slanting insertion, of an FFC can cause a short circuit resulting in broken elements on the circuit board. Be sure to connect the FFCs to the connectors properly with great care.

CAUTION

- In reassembly, place the wiring of electric parts in specified positions. (If wiring is located in places other than specified, cables can come in contact with a sharp edge or the anti-noise margin may lessen.)
- As necessary, if you remove each cover and operate the printer, care should be taken not to get injured by the operation of the drive system units.
- The cutter blade is extremely sharp, so care should be taken not to injure yourself when handling it.
- An ultra-hardened blade is used for the cutter blade, and physically, it is extremely brittle material, so care should be taken not to bump it against any of the metal parts of the printer, etc. and damage it.
- When performing service operations on items which are controlled as after service parts but which no procedures have been provided for, the state of the parts should be observed closely before beginning the operation to get a thorough idea of how to proceed.
- If you have to loosen a screw that has blue screw-lock applied to its head, make sure you apply blue screw-lock again when reassembling.

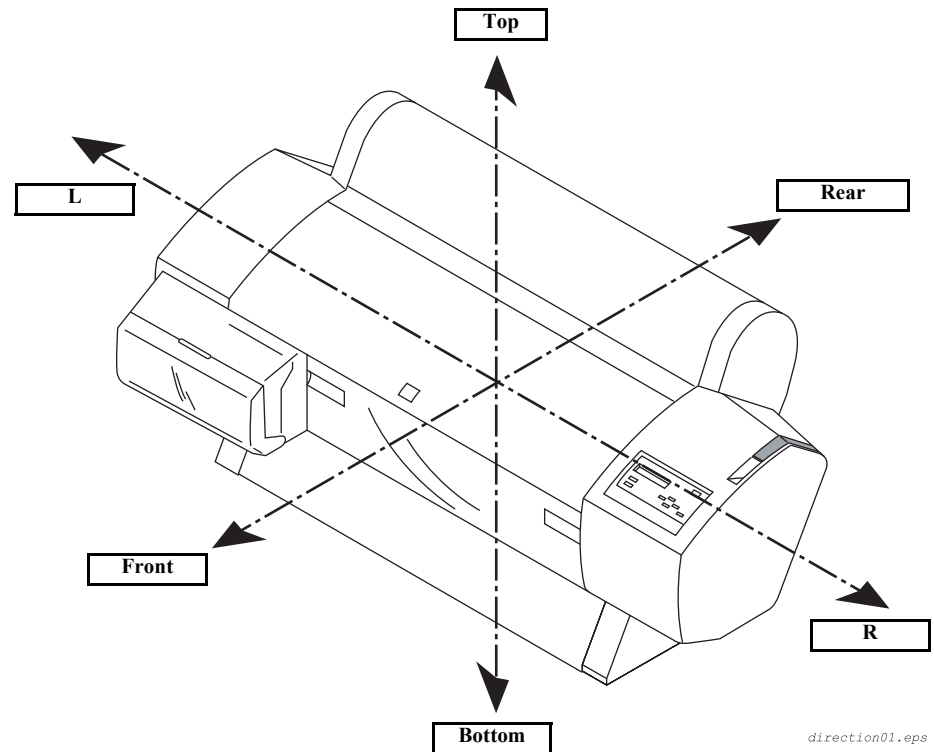

Figure 4-1. Directional View of the Printer

4.1.2 Tools

This section lists the tools necessary to disassemble or assemble the printer.

Table 4-1. Necessary Tools

Tool	Part Code	Notes
(+) Phillips screwdriver #2	Commonly available tools, no special tools necessary	longer than 250mm is helpful
(+) Phillips screwdriver #1		
(-) Standard screwdriver		
Round-nosed pliers		
Tweezers		
#E 589 Torque Wrench (6 mm x 1.0 kg) or #f760 Torque Wrench	B765106901 1059914	For tube coupling screws.
Hex Wrench	Part with Exclusive Stand (Commercially available part)	5.5 mm *1
PF Loop Scale ASSY Assembly tool	1051765	Exclusive tool No. #f730
PF Loop Scale Attachment tool	1051767	Exclusive tool No. #731
Ink Cartridge*2		
Draining cartridge*2		
Maintenance Tank*2		
PF_ENC		
CR_ENC		
Cutter		

Note *1: This hex wrench is necessary only when removing the stand (feet).

*2: 7 of these cartridges are necessary for one operation.

4.1.3 Screw List

The following table lists all the screws used in this printer.

Table 4-2. Screws

Type	Color	Description
CB M3×6	White	(+) Bind
CBP M3×6	Silver	(+) Bind P-tight
CBP M4×10	Black	(+) Bind P-tight
CBS M3×10	White	(+) Bind S-tight
CBS M4×6	White	(+) Bind S-tight
CBS M2×8	White	(+) Bind S-tight
CBS M3×6	White	(+) Bind S-tight
CBS M4×8	White	(+) Bind S-tight
CBS M3×10	White	(+) Bind S-tight
CUPS M3×6	White	(+) Cup S-tight
CUPS M4×6	White	(+) Cup S-tight
CUPS M4×8	White	(+) Cup S-tight
CPP M3×8	White	(+) Cup P-tight
CPS M3×12	White	(+) Crosshead Pan S-tight
CP M3×6	White	(+) Crosshead Pan
CP(W) M2×12	Silver	(+) Crosshead Pan, washer
CP(W) M2×8	Silver	(+) Crosshead Pan, washer
CP(W) M3×6	Silver	(+) Crosshead Pan, washer
CP(W) M3×8	Silver	(+) Crosshead Pan, washer
CP(W) M3×25	Silver	(+) Crosshead Pan, washer
CP(W) M4×8	Silver	(+) Crosshead Pan, washer
CP(W) M4×10	Silver	(+) Crosshead Pan, washer
CP(W) M4×40	Silver	(+) Crosshead Pan, washer
Flush head screw M3×6	White	(+) Flush head
Truss screw M4×6	White	(+) Truss screw
Toothed washer M3	White	Outer teeth
Toothed washer M4	White	Outer teeth

4.1.4 Disassembly Flow

Refer to Figure 4-2 when determining the disassembly flow.



This printer has been assembled with high accuracy of 1/100 mm. Therefore, you are prohibited to disassemble the frames or some specific parts. Permission of disassembly and assembly or removal and installation is limited to the parts provided with a parts number in the ASP List in Chapter 7. (If any parts other than specified are disassembled or removed, there may be a case you can not repair the printer except at the factory.)

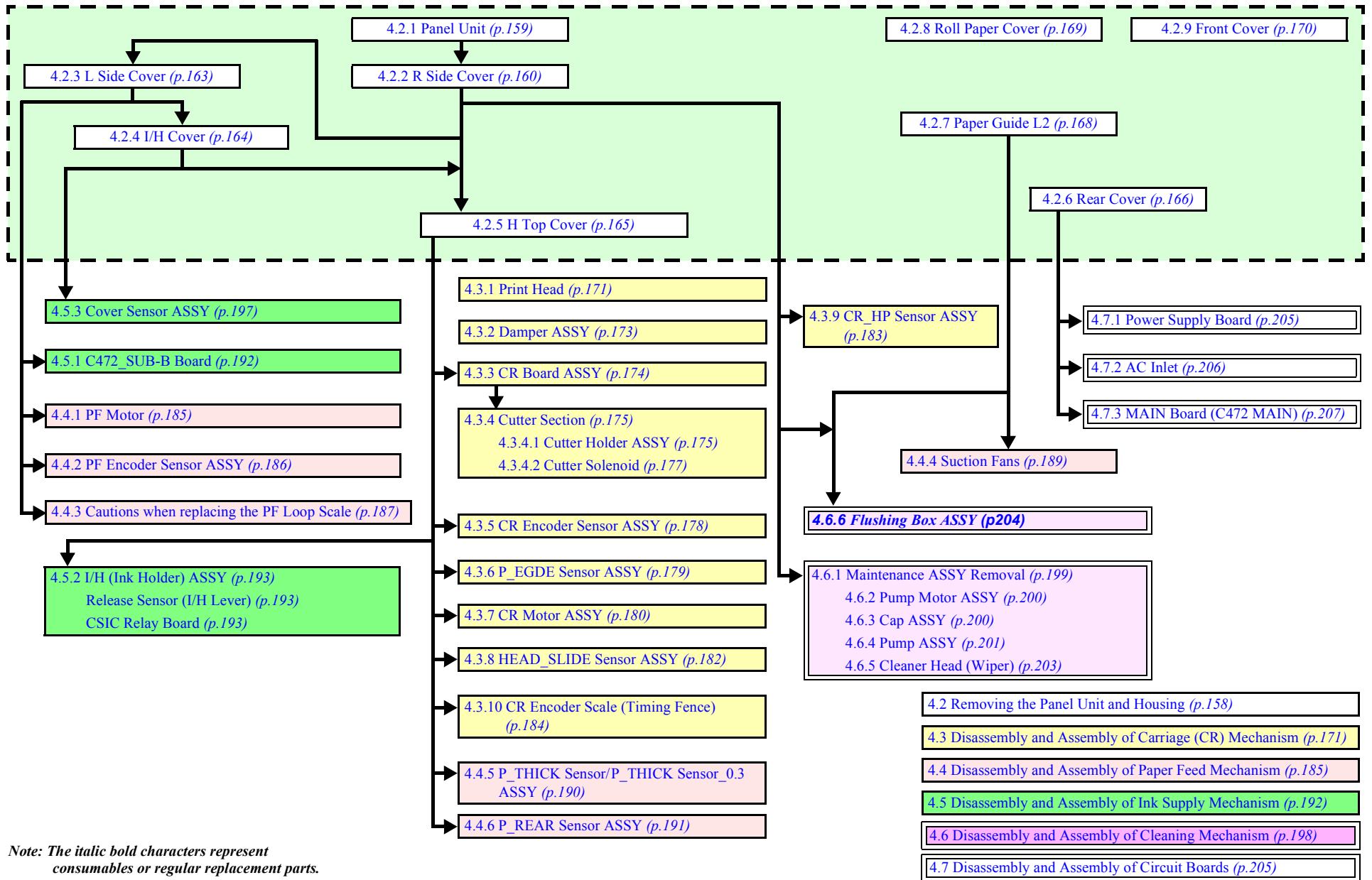

Figure 4-2. Disassembly Process Flowchart

4.2 Removing the Panel Unit and Housing

This section describes the removal procedure for printer housing parts. See below for an illustration of the housing parts.

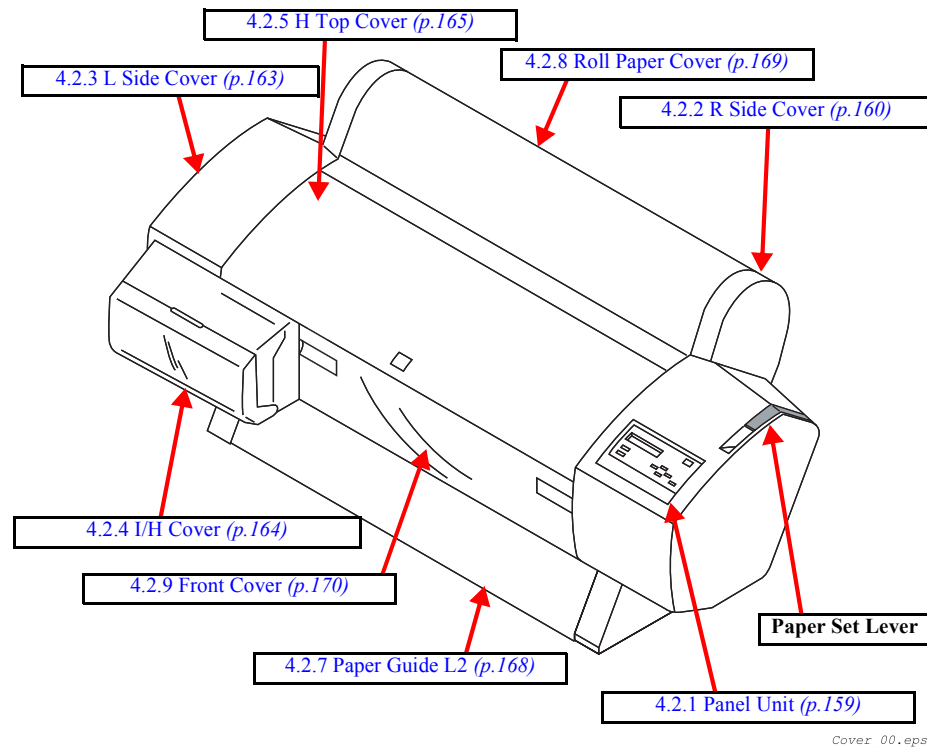

Figure 4-3. Housing Part Diagram

4.2.1 Panel Unit

1. Release the clips on both sides of the control panel unit and pull slightly away from the R Side Cover.
(See Figure 4-4)
2. Remove the FFC cable from the connector and hook.
(See Figure 4-5)



Make sure that the Panel FFC does not get twisted round the carriage driven pulley inside the printer.

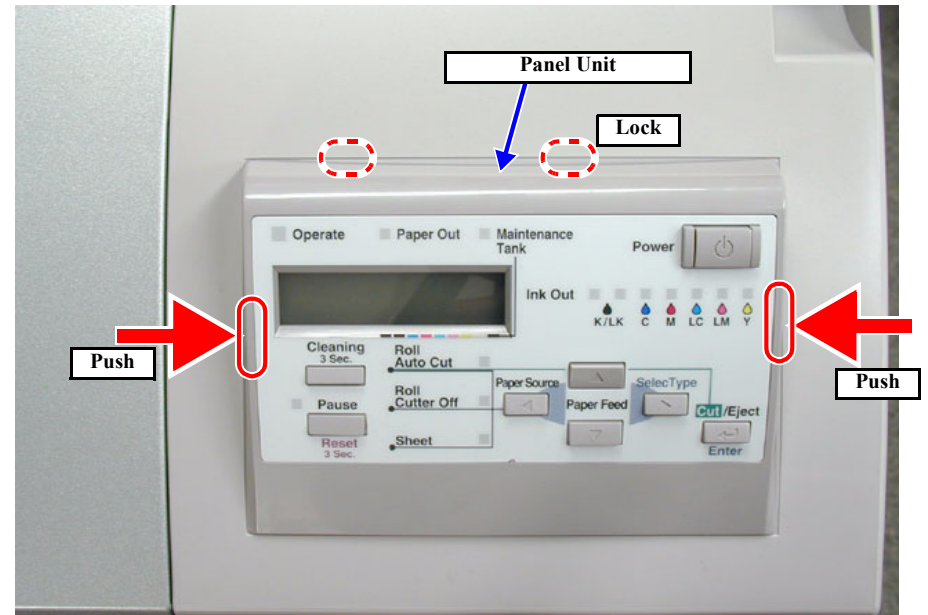

Figure 4-4. Panel Unit Removal 1/2

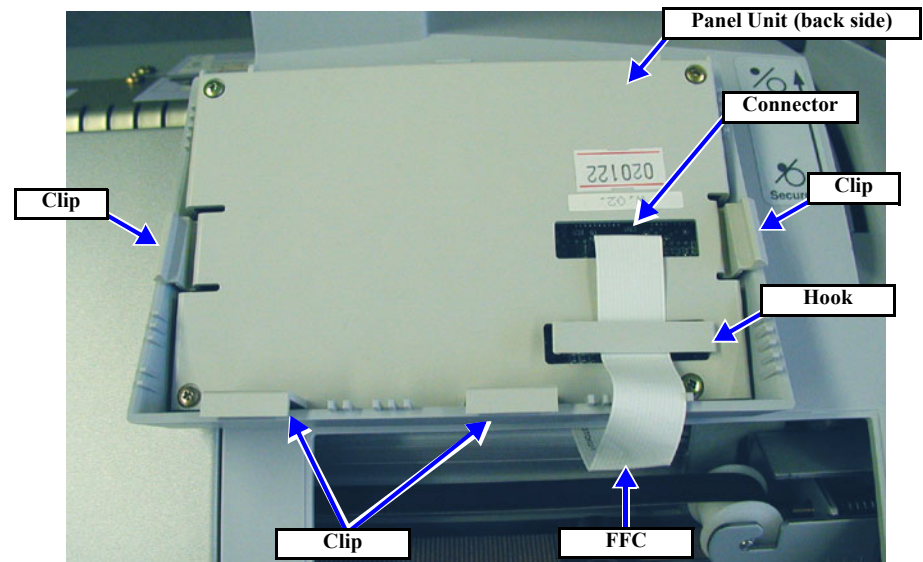

Figure 4-5. Panel Unit Removal 2/2

4.2.2 R Side Cover

1. Remove the *Panel Unit*. (p.159)
2. Push back the Paper Set Lever to the released position. (See Figure 4-6)
3. Remove two black screws (CBP: M4×10) from the lever handle, and remove the handle.
4. Using a (-) driver or similar tool, remove the lever blind cap.

CHECK POINT



Take care not to drop the lever blind cap into the printer.

5. Open the roll paper cover. (See Figure 4-7)
6. Remove the one black screw (CBP: M4×10) from inside the printer.

REASSEMBLY



Adjust the height of the Paper Set Lever by means of the black screws so that the Paper Set Lever does not come in contact with the Lever Blind Cap.

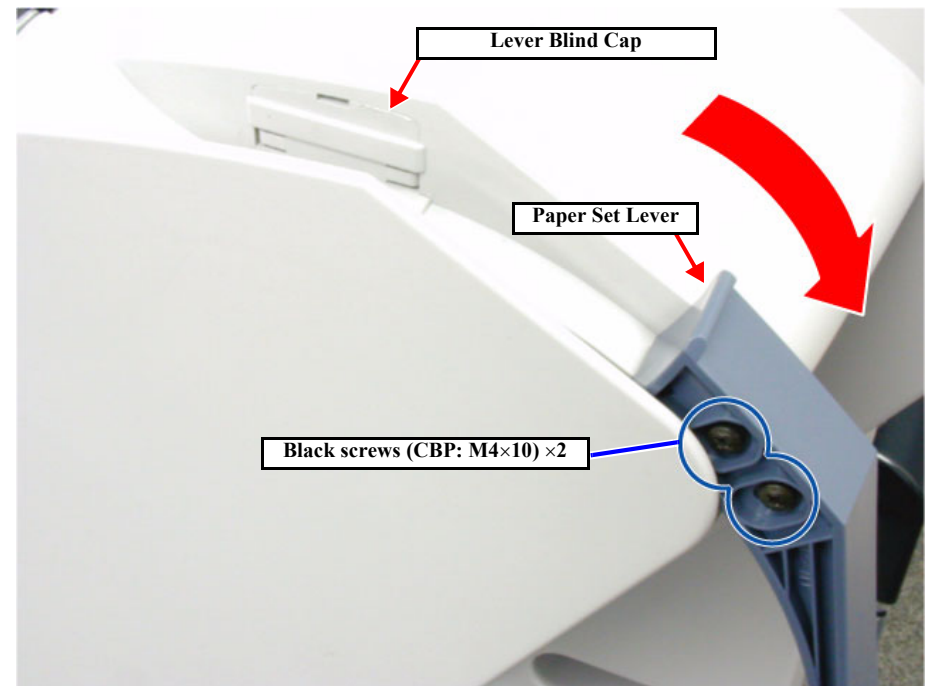

Figure 4-6. R Side Cover Removal 1/5

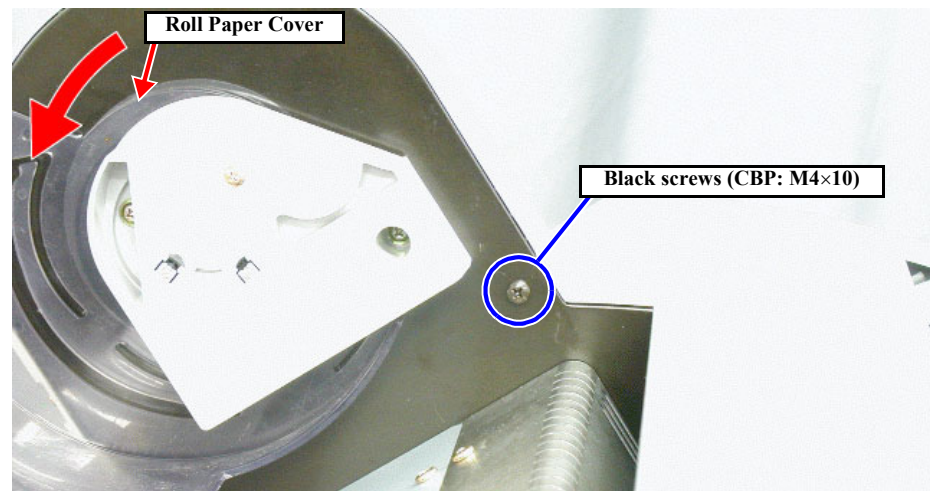

Figure 4-7. R Side Cover Removal 2/5

7. From the rear side, remove one screw (CUPS: M4×8).
8. From the right side remove two screws (CUPS: M4×8).
9. Remove the Maintenance Tank.

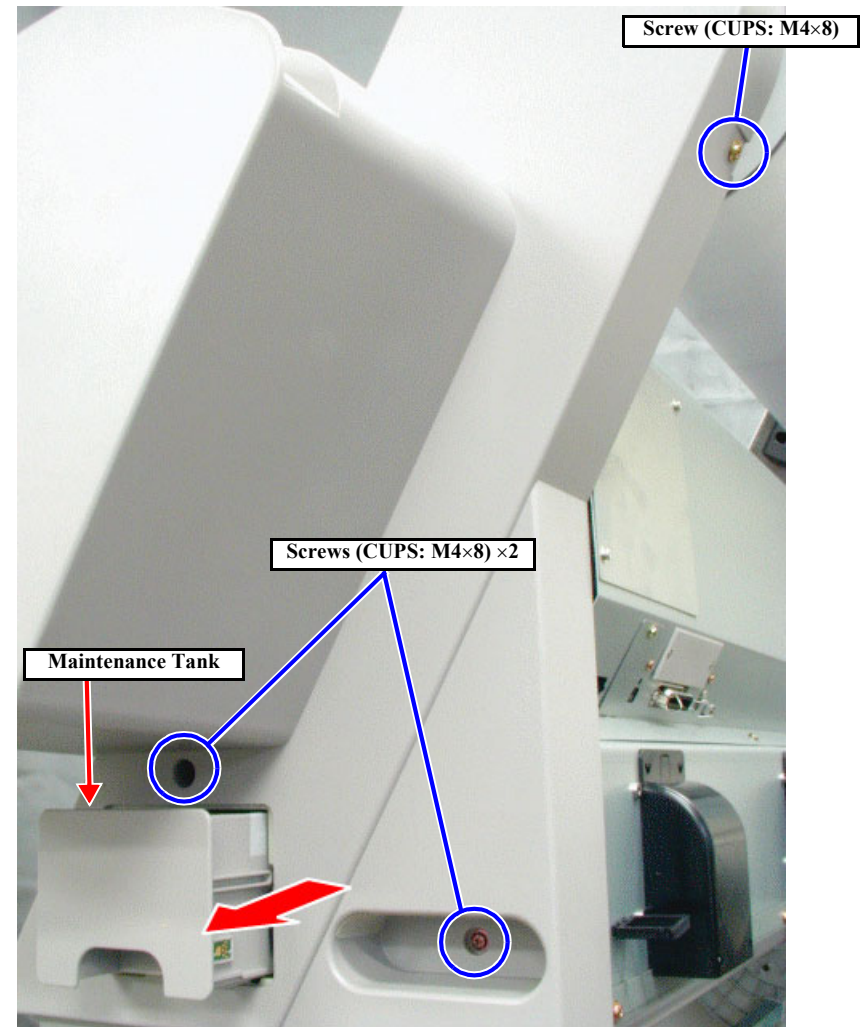

Figure 4-8. R Side Cover Removal 3/5

10. Open the Front Cover. (See Figure 4-9)
11. Remove one black screw (CBP: M4×10).
12. Bring down the Paper Set Lever to the front. (See Figure 4-10)
13. Remove the R Side Cover by lifting it outward.

REASSEMBLY

In installing the R Side Cover, install the Lever Blind Cap before tightening the screws.

If you have dropped the Lever Blind Cap into the printer body, remove the R Side Cover from the printer body and take out the Lever Blind Cap.

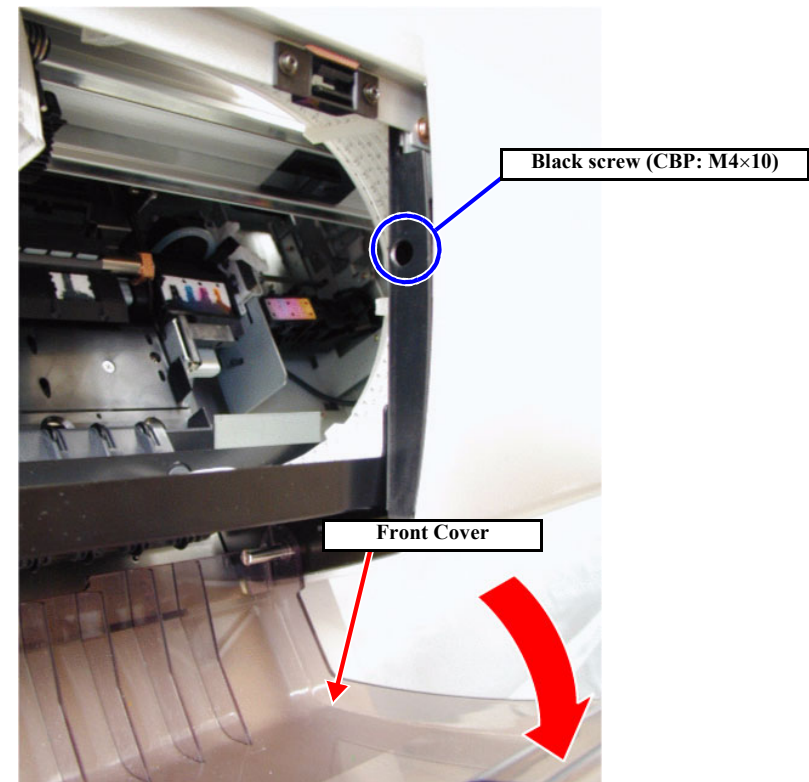

Figure 4-9. R Side Cover Removal 4/5

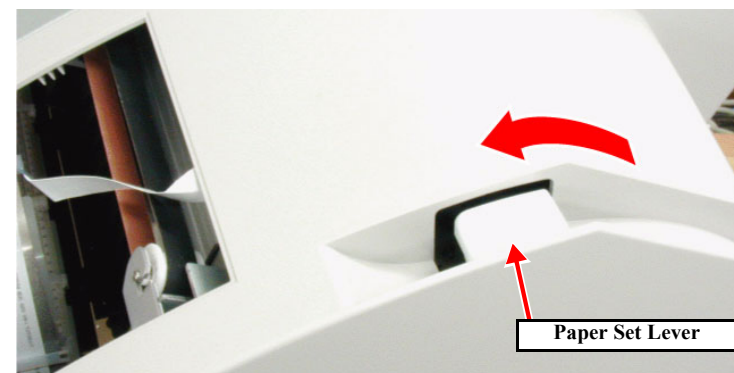

Figure 4-10. R Side Cover Removal 5/5

4.2.3 L Side Cover

1. Open the roll paper cover. (See Figure 4-11)
2. Remove the one black screw (CBP: M4×10) inside the printer.
3. From the back side, remove one screw (CUPS: M4×8). (See Figure 4-12)
4. From the outside, remove two screws (CUPS: M4×8).
5. Remove the L side cover.

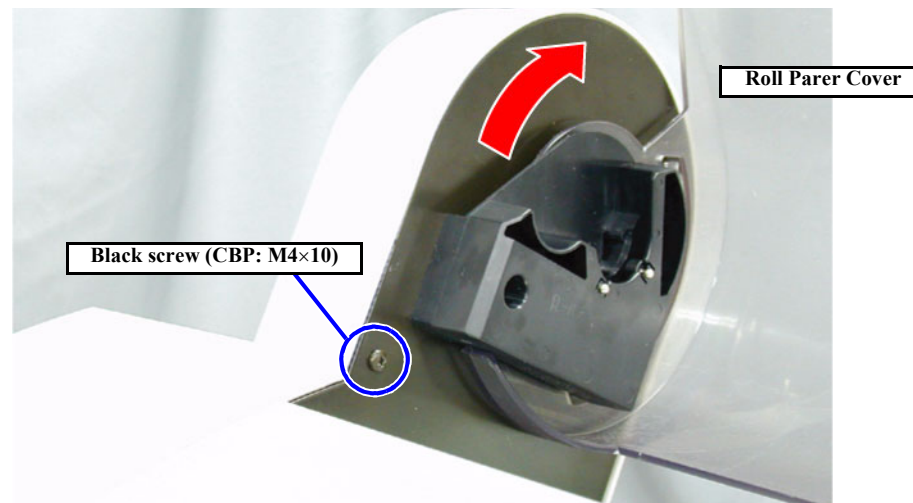

Figure 4-11. L Side Cover Removal 1/2

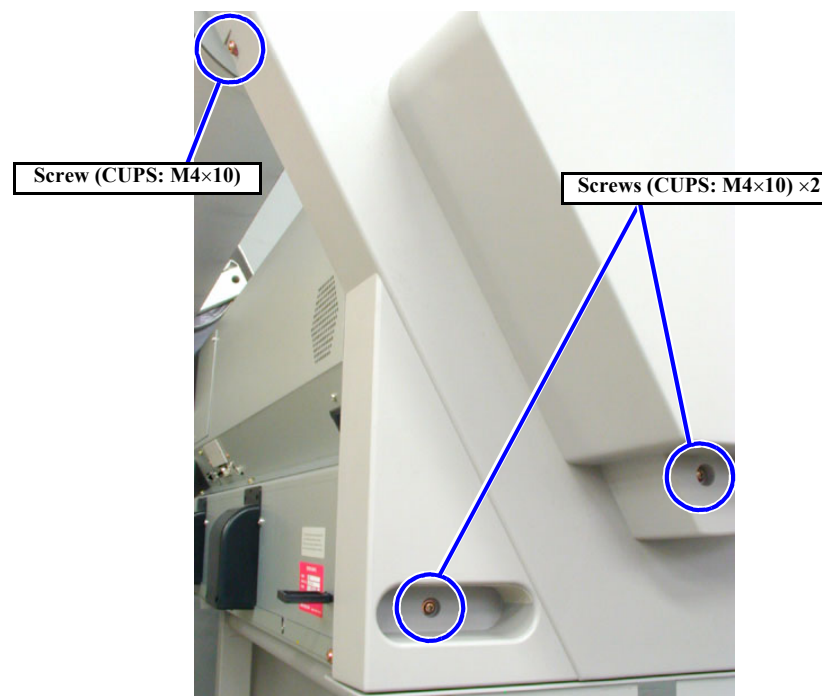

Figure 4-12. L Side Cover Removal 2/2

4.2.4 I/H Cover

1. Remove the *L Side Cover*. (p.163)
2. Open the I/H Cover Lid.
3. Remove one black screw (M3×6), then remove the lever cap.(See Figure 4-13)
4. Remove two screws (CBS: M3×10), then remove the I/H Cover and I/H Cover Lid.
(See Figure 4-13)



For easy removal and installation of the I/H Cover, set the I/H Lever in the raised (Release) position.

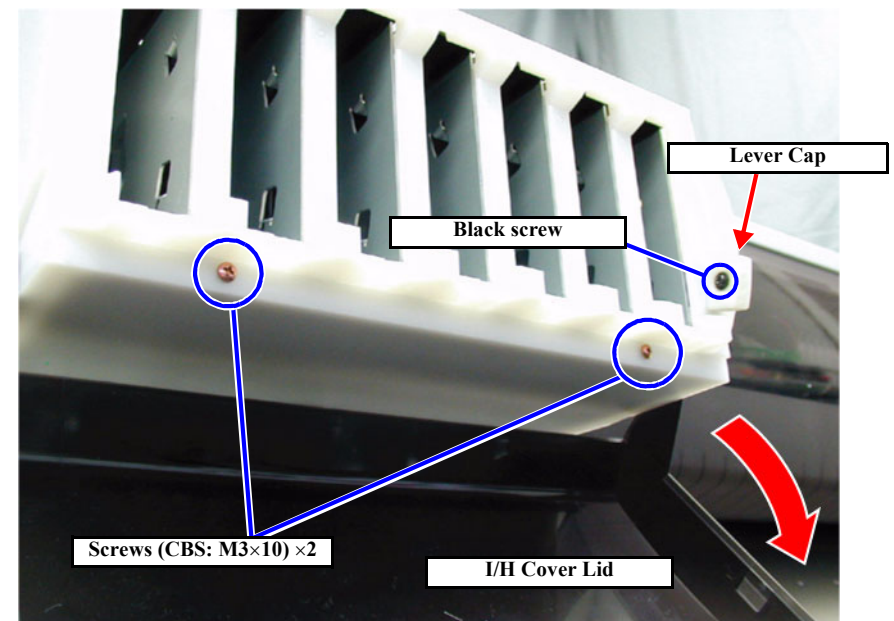
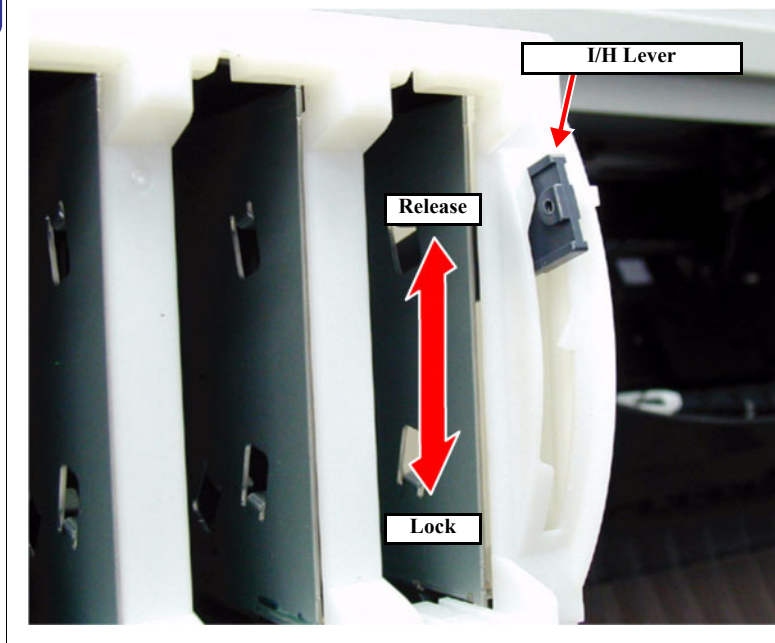

Figure 4-13. I/H Cover Removal

4.2.5 H Top Cover

1. Remove the *R Side Cover*. (p.160)
2. Remove the *L Side Cover*. (p.163)
3. Remove the *I/H Cover*. (p.164)
4. Open the Front Cover.
5. From the left side, remove one screw (CUPS: M4×8).
(See Figure 4-14)
6. Remove the screw (CUPS: M4×8) at the front left of the printer.
7. Remove the screw (CUPS: M4×8) at the front right of the printer.
8. From the right side, remove one screw (CUPS: M4×8).
(See Figure 4-15)
9. To avoid damaging the P_THICK Sensor or P_THICK_0.3 Sensor, bring down the Paper Set Lever toward you (to the paper holding position).
10. Pull up the H Top Cover rearward and remove it.
In doing so, take care not to lose the plate which is also locked with the front left screw.

CAUTION

When removing the H Top Cover, care should be taken not to damage the P_THICK Sensor and P_THICK Sensor_0.3. To avoid damaging them, bring down the Paper Set Lever toward you (to the paper holding position) first and shift the H Top Cover rearward in an oblique direction for its removal.

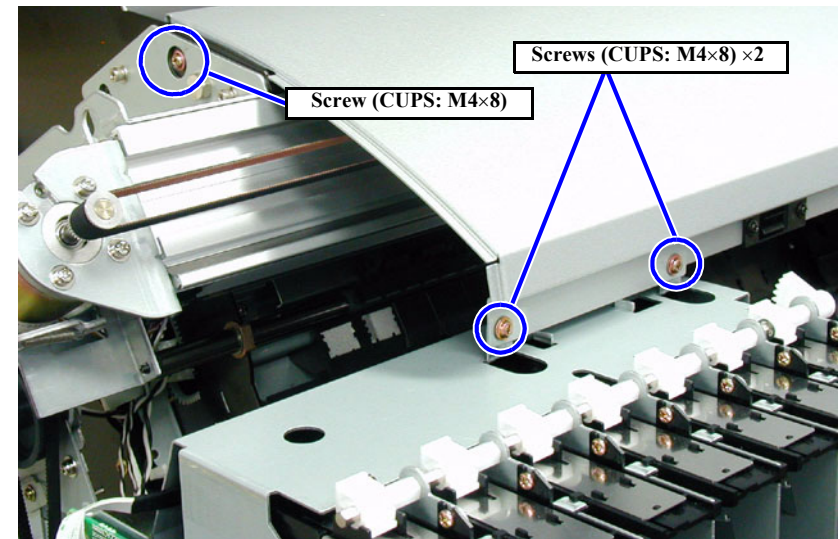

Figure 4-14. H Top Cover Removal on left side

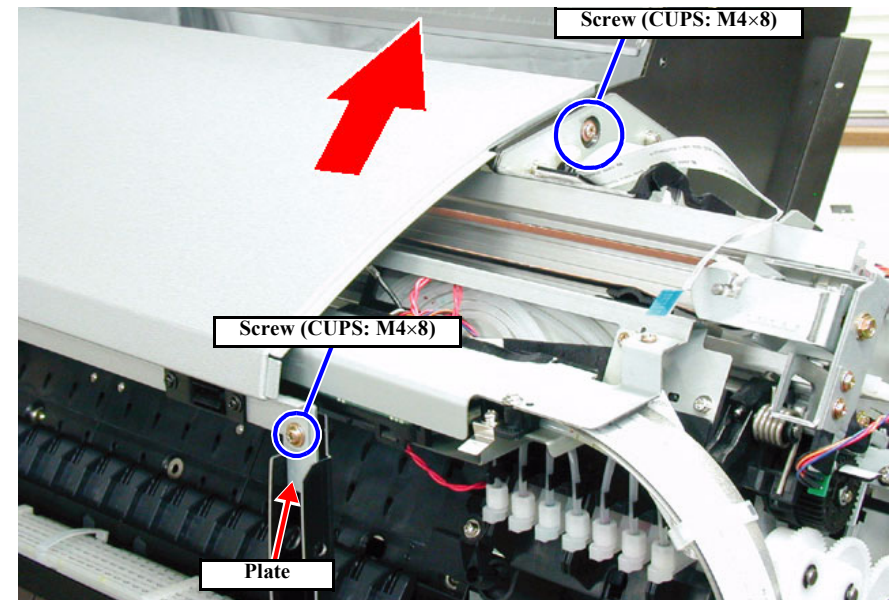

Figure 4-15. H Top Cover Removal on right side

4.2.6 Rear Cover

1. From the rear side, remove two screws (CPS: M3×12), and remove the blank panel.
(See Figure 4-16)
2. Remove the two screws (CP: M3×6) securing the parallel interface and remove the one screw (CBS: M3×6) securing the USB interface.
3. Remove one screw (CBS: M3×6) holding the AC inlet top. (See Figure 4-17)
4. Remove the three screws (CBS: M4×8) (six screws for Stylus Pro 9600) holding the rear cover bottom.
5. Open the Roll Paper Cover.
6. Remove the three screws (CBS: M4×8) (six screws for Stylus Pro 9600) holding the rear cover top, then remove the rear cover, while pulling it rearward.

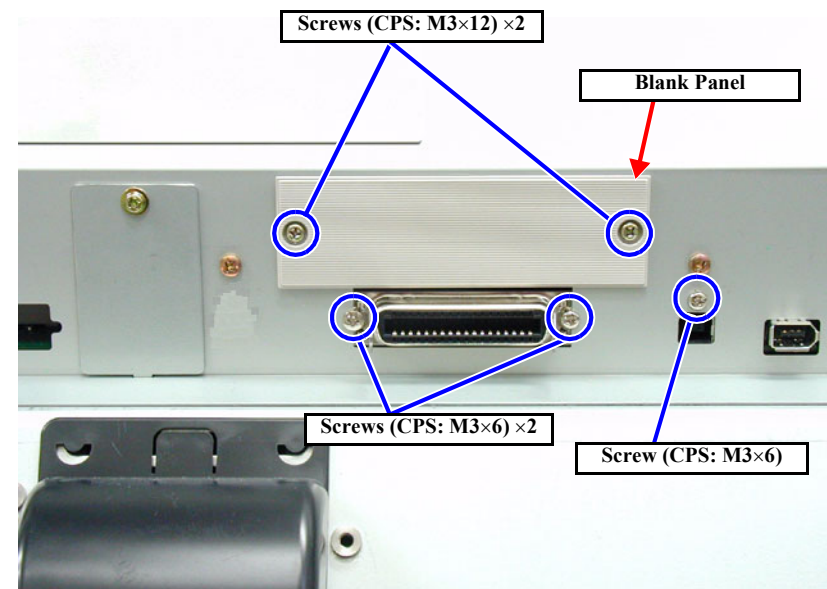

Figure 4-16. Rear Cover Removal 1/2



To avoid getting hurt with sharp frame edges, be sure to wear gloves when performing the following work:

- Removing and installing the Rear Cover
- Inserting your hand through the opening in the Access Cover (see Check Point on the next page)

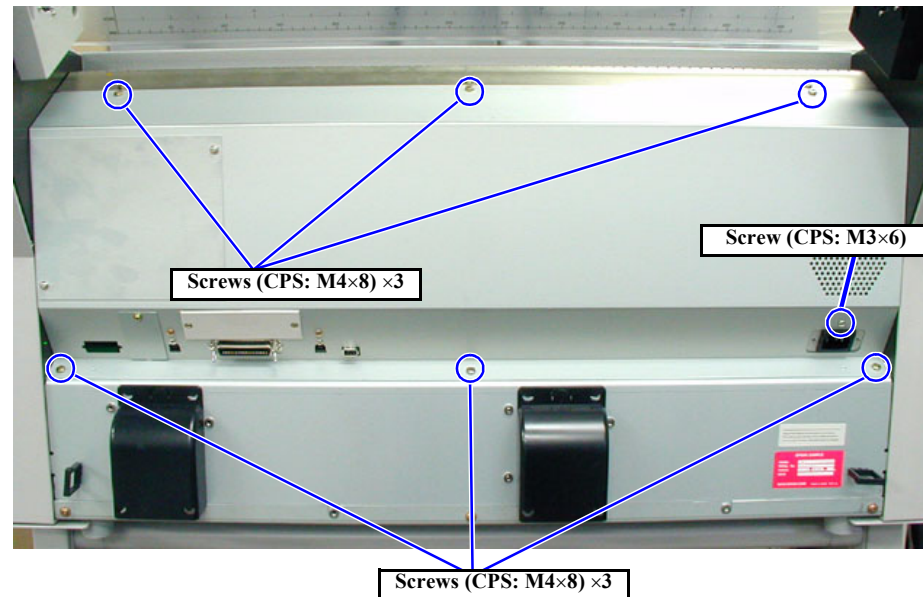
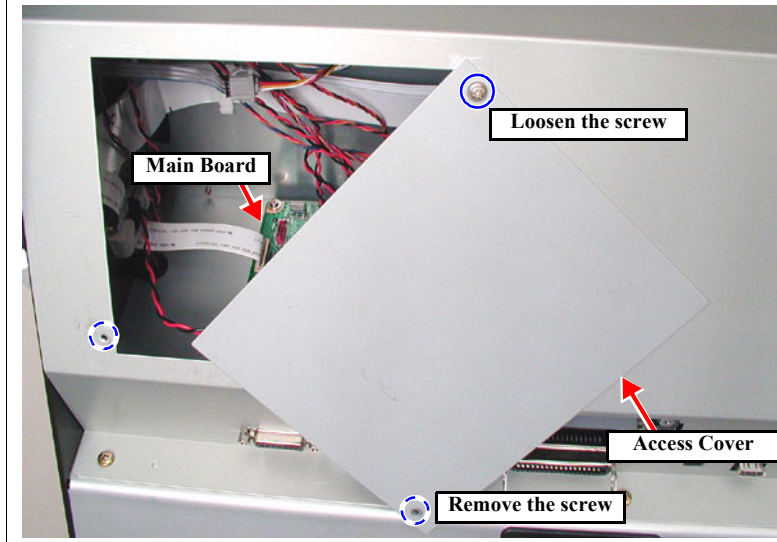

Figure 4-17. Rear Cover Removal 2/2

**CHECK
POINT****Removing the Access Cover**

For disconnecting connectors for various units from the Main Board Assy, it is not always necessary to remove the Rear Cover. Remove the Access Cover, and you will be allowed to do almost all such work.



4.2.7 Paper Guide L2

1. From the front, remove four screws (Truss: M4×6).
(See Figure 4-18)
2. Remove the Paper Guide L2.



Install the Paper Guide L2 so that all its projections are fit in the notches of the Paper Guide L properly. (See Figure 4-19)

- Number of notches:
Stylus Pro 7600: 5
Stylus Pro 9600: 8

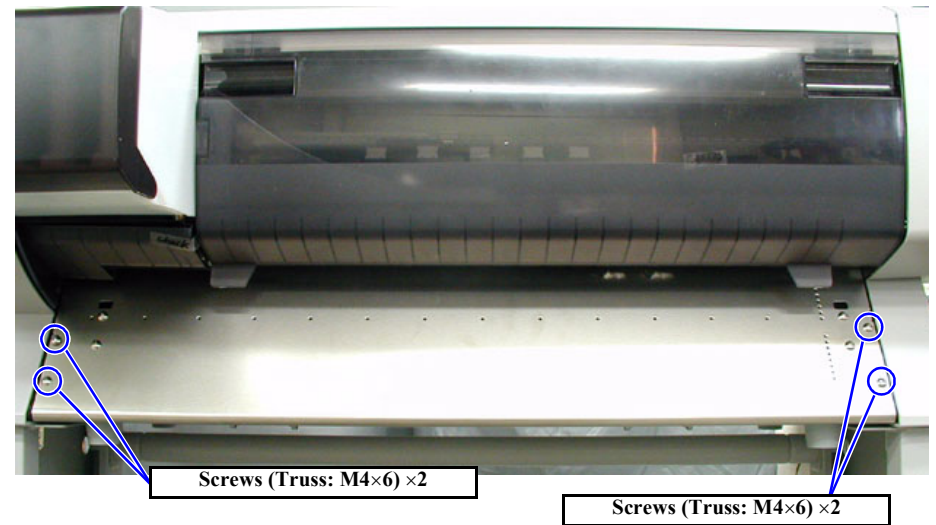
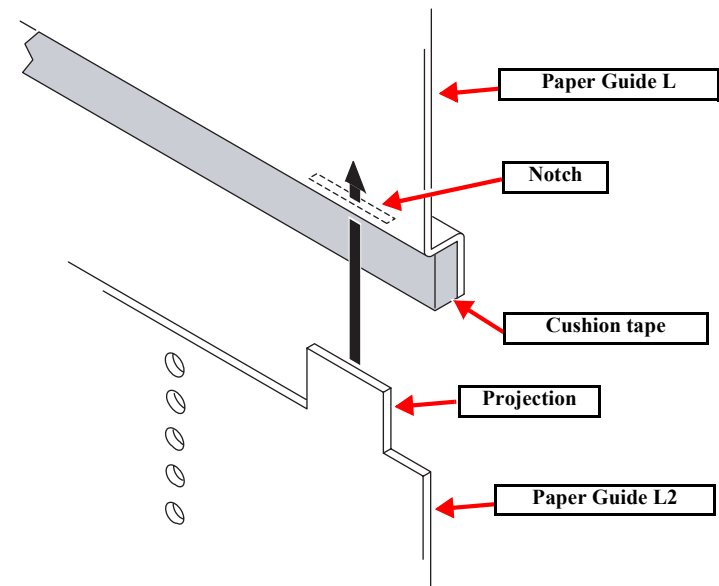

Figure 4-18. Paper Guide L2 Removal



Cover_PGL10.eps

Figure 4-19. Paper Guide L2 Installation

4.2.8 Roll Paper Cover

1. Open the Roll Paper Cover. (See Figure 4-20)
2. Remove two screws (CPS: M4×8) securing the black spindle support (Spindle Support L) on the left, and then remove the spindle support.
3. Remove the two screws (CPS: M4×8) and one screw (M4×12) securing the gray spindle support (Spindle Support R) on the right, and then remove the spindle support. (See Figure 4-20)

REASSEMBLY



When installing the white spindle support (Spindle Support R), install the transparent washer, wave washer and printer body frame on the outside of the Roll Paper Cover in the named order.

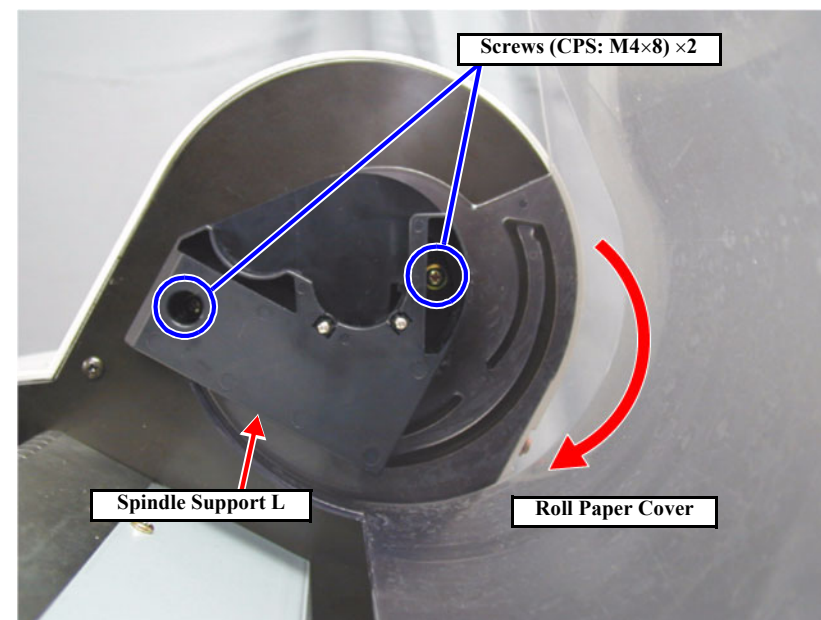
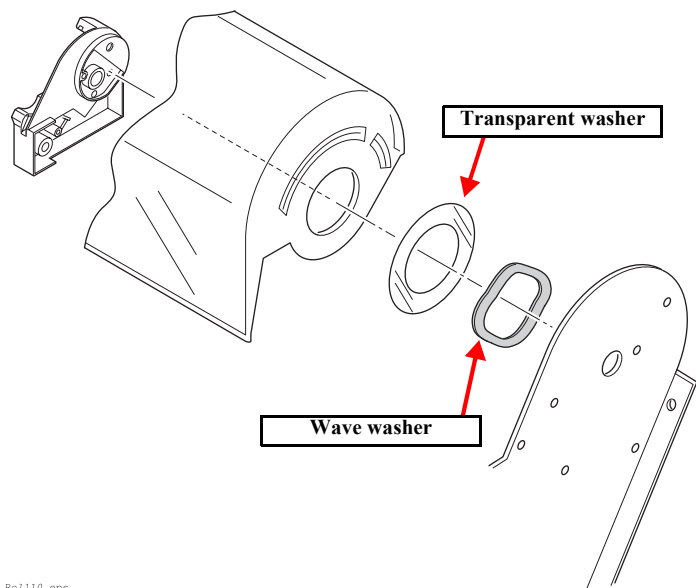

Figure 4-20. Roll Paper Cover removal

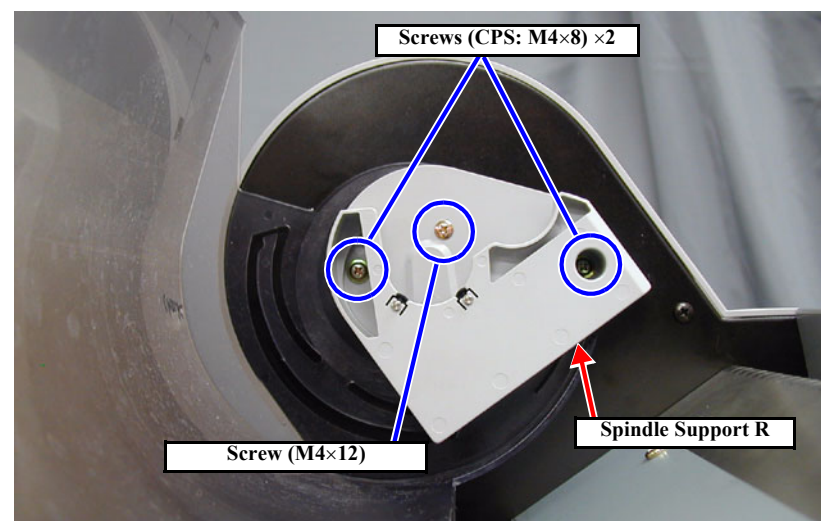

Figure 4-21. Roll Paper Cover removal

4.2.9 Front Cover

1. Open the Front Cover.
2. Push in the two hooks to the left of the cover and remove the Front Cover Support. *(See Figure 4-22)*
3. Release the Front Cover Spring L from the Front Cover Spring Catch Shaft on the left side of the Front Cover. *(See Figure 4-23)*
4. Remove the Plastic Stop Wheel E5 on the left side of the Front Cover and move the Front Cover Fulcrum Pin outward for its removal.
5. Release the Front Cover Spring R from the Front Cover Spring Catch Shaft on the right side of the Front Cover.
6. Remove the Front Cover from the Front Cover Fulcrum Pin R.

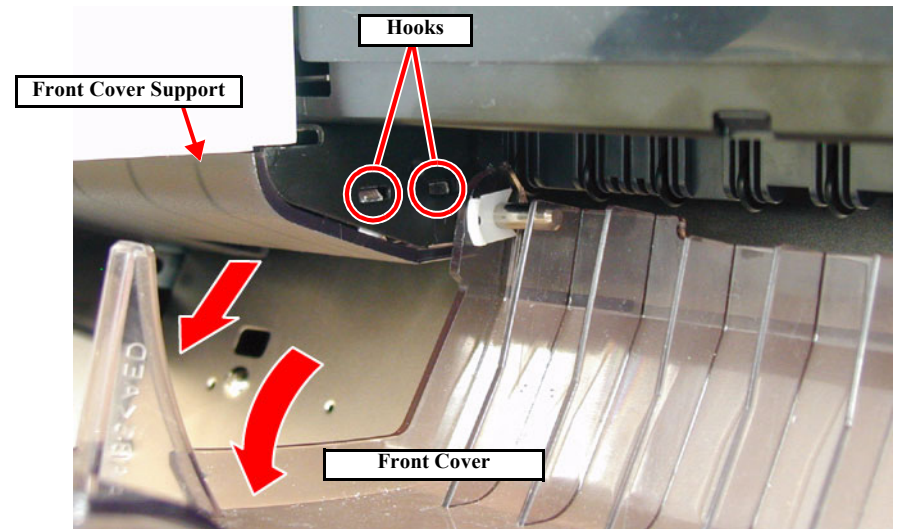
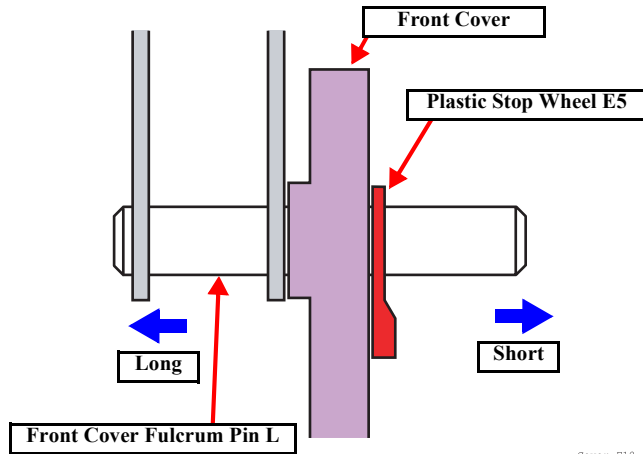

Figure 4-22. Front Cover Support Removal



Install the Plastic Stop Wheels in the correct orientations, respectively.



The cover switch holder installation position should be checked so that the cover sensor ASSY is linked to the front cover when it opens and closes.

Refer to "5.1.4.9 Cover Sensor ASSY Adjustment" (p.216)

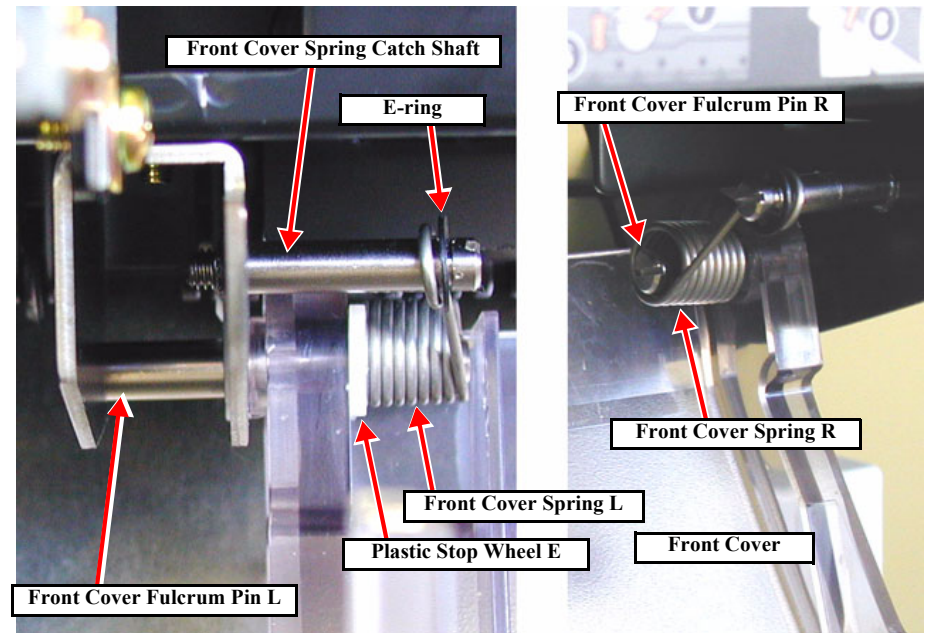

Figure 4-23. Front Cover Removal

4.3 Disassembly and Assembly of Carriage (CR) Mechanism

4.3.1 Print Head

CAUTION

When unlocking the carriage, do not move the carriage by about 2 cm or more with the cutter pushed into the innermost position; otherwise, the cutter edge would be damaged.

CHECK POINT

When replacing the print head with a new one, execute ink discharge (“*Ink Blowing*” on page 256) beforehand.

1. Execute ink discharge operation to discharge the ink from all the ink passages.
2. While pushing the cutter area gently, shift the carriage to the left about 2 cm to unlock the carriage and then move the carriage to the printer center. (See Figure 4-24)
3. Loosen the one screw (CP(W): M3×6) securing the front end of the damper holder and separate the Damper Unit from the print head. (See Figure 4-25)

CHECK POINT

When removing the head, hang the hook of the Damper Unit in the hole of the bottom plate of the CR Board Assy so that work will not be obstructed by the Damper Unit.

In addition, for easier work, you are advised to lift with Scotch tape to such a degree that no significant load is applied to the ink tubes.

REASSEMBLY

- There is a hook 2 cm high at the center of the head. Install the Damper Unit with care not to hit it against the hook.
- When installing the Damper Unit, before tightening the screw, press the lower area of the Damper with your fingers so that it comes in close contact with the print head.

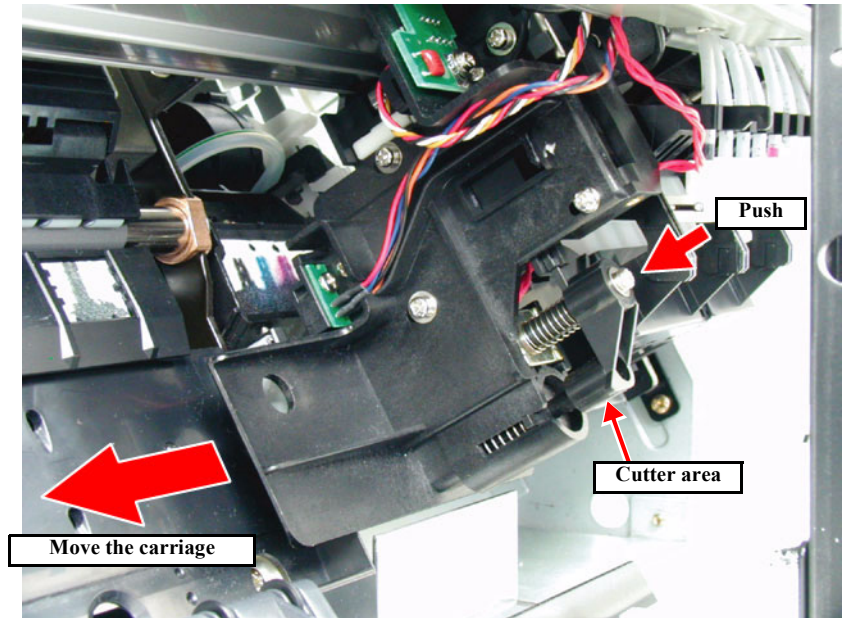

Figure 4-24. Carriage Lock Release

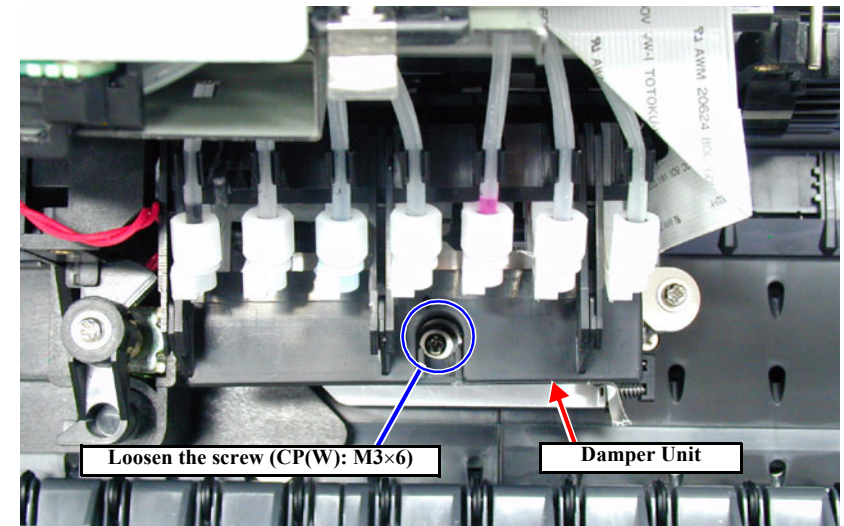

Figure 4-25. Damper Holder Loosening

4. Loosen the left screw for the Head Holder, remove the right screw (M3×6) and release the Head Holder downward. (See Figure 4-26)
5. Take out the head by lifting its inner side and release the 2 FFCs. (See Figure 4-27)



- Take care not to touch the nozzle side of the print head to be installed and not to let dust or dirt adhere to the nozzles.
- When installing the carriage, take care not to scratch the nozzle side.



- When replacing the print head, the following adjustment procedures are required.
- Refer to “5.1.4.1 Print Head Adjustment” (p.212)

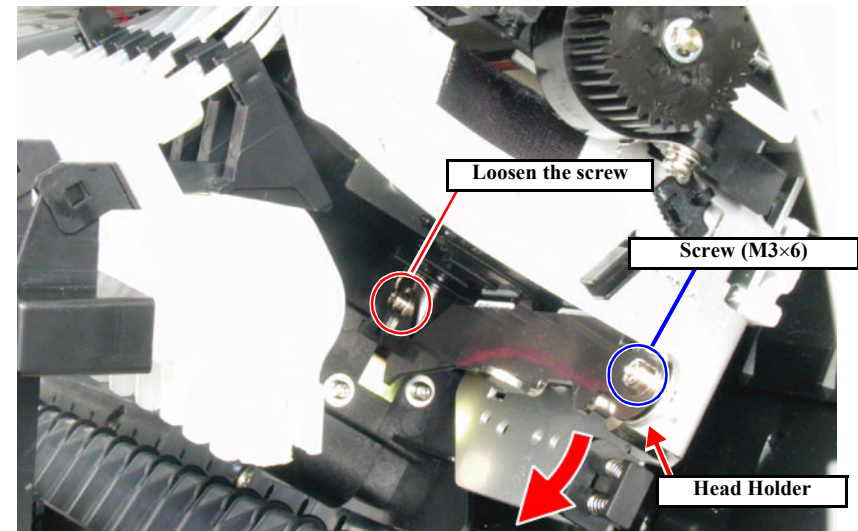

Figure 4-26. Head Holder Release

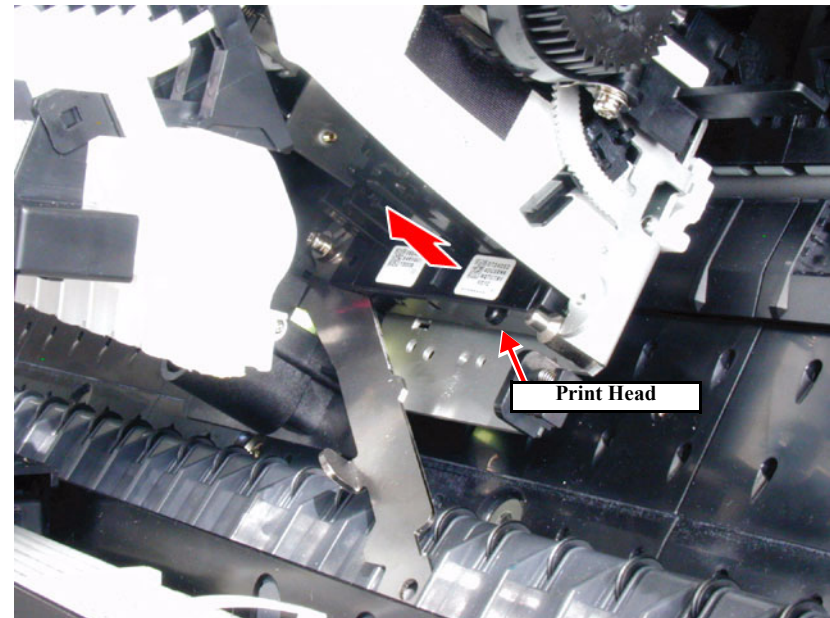

Figure 4-27. Head Removal

4.3.2 Damper ASSY

CHECK POINT



Execute ink discharge (“*Ink Blowing*”) before removing the Damper ASSY.
Refer to “5.2.3.20 Clean Head (p.256)”.

CAUTION



- If you press on the transparent film on the damper's right side surface with your fingers, the ink with which the inside is filled will be expelled, so do not press on this part.
- The transparent film on the damper's side is delicate, so be careful not to damage it while working.

1. Execute ink discharge operation to discharge the ink from all the ink passages.
2. While pushing the cutter area gently, shift the carriage to the left about 2 cm to unlock the carriage and then move the carriage to the printer center. (See Figure 4-24)
3. Loosen the one screw (CP(W): M3×6) securing the front end of the damper holder and separate the Damper Unit from the print head. (See Figure 4-25)
4. Disengage the three hooks of the Damper Holder and remove the Damper Holder. (See Figure 4-28)
5. Pull out the relevant Damper ASSY from the Damper Holder, loosen the coupling screw and separate the Damper ASSY from the ink tube. (See Figure 4-29)

NOTE: Take care not to lose the O-ring inside the coupling screw.

REASSEMBLY



- There is a hook 2 cm high at the center of the head. Install the Damper Unit with care not to hit it against the hook.
- When installing the Damper Unit, before tightening the screw, press the lower area of the Damper with your fingers so that it comes in close contact with the print head.
- Secure the coupling screw and the ink tube by tightening at the specified torque. (2 ~ 2.5 kg/f)

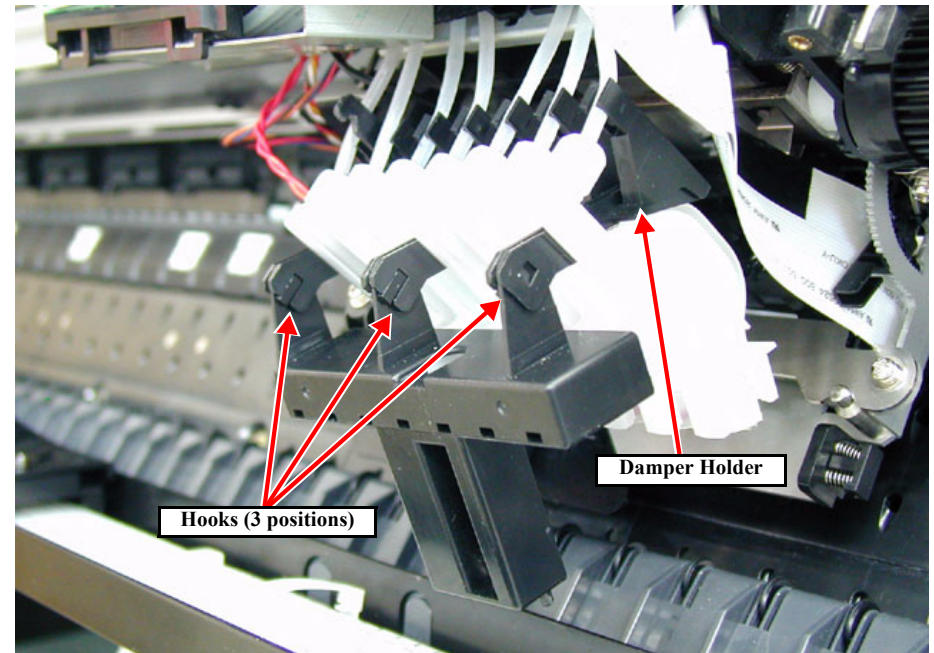

Figure 4-28. Damper Holder Removal

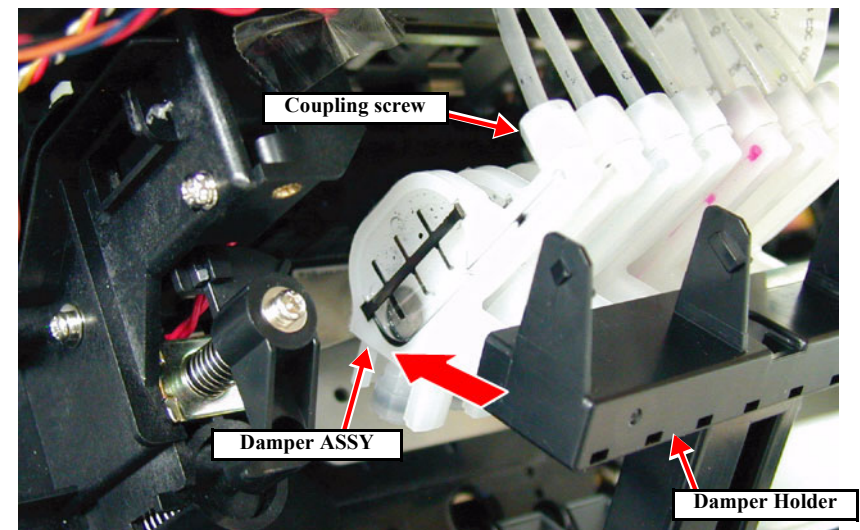

Figure 4-29. Damper ASSY Removal

4.3.3 CR Board ASSY

1. Remove the R Side Cover. (p.160)
2. Remove the L Side Cover. (p.163)
3. Remove the I/H Cover. (p.164)
4. Remove the H Top Cover. (p.165)
5. Remove one screw (CPP M3×6), two screws (CP(W): M3×6) and one screw (M3×16) securing the CR Board Guide, and also the ground line and the toothed washer (M3), and remove the CR Board Guide. (See Figure 4-30)
6. Disconnect the following eight connectors (with lock) connected to the CR Board. (See Figure 4-31)

Table 4-3. Connectors on CR Board

Connector Type	Connected to
5-Pin (white)	CR Encoder Sensor
4-Pin (black)	P_EDGE Sensor
2-Pin (white)	Cutter Solenoid
FFC (lock type)×2	Print Head
FFC (lock type)×3	Main Board

7. Remove the two screws (CPP: M3×8) securing the CR Board ASSY and remove the CR Board ASSY. (See Figure 4-32)



The screw on the far left side used to fasten the CR board guide plate should be tightened together with the ground wire, toothed washer, CR board guide and CR board ASSY, in that order.



When connecting an FFC, take great care not to insert it aslant. (Inserting aslant can cause a short circuit of signals, thus resulting in broken circuit elements.)

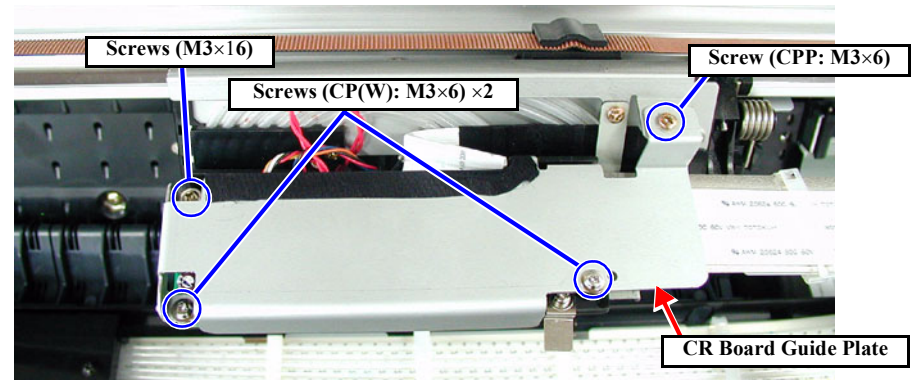

Figure 4-30. CR Board Guide Removal

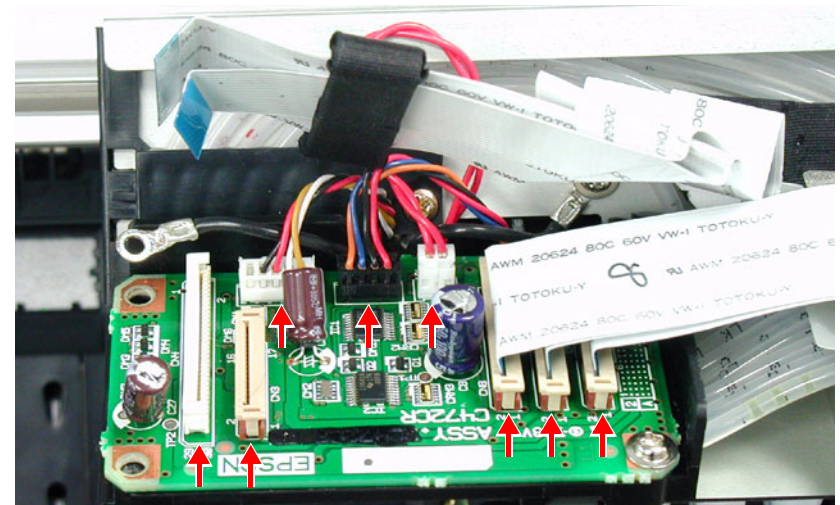

Figure 4-31. CR Board Connectors Disconnection

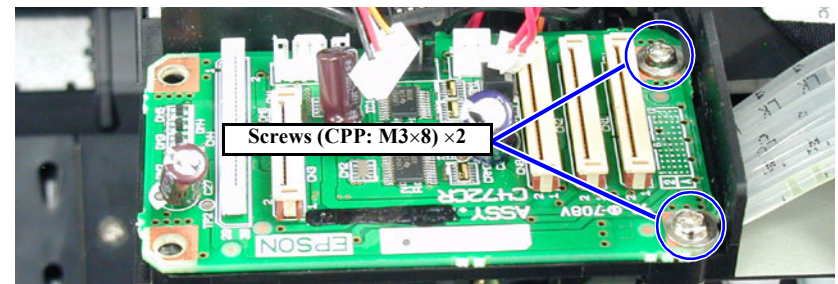

Figure 4-32. CR Board Removal

4.3.4 Cutter Section

4.3.4.1 Cutter Holder ASSY



When unlocking the carriage, do not move the carriage by about 2 cm or more with the cutter pushed into the innermost position; otherwise, the cutter edge would be damaged.

1. Remove the *R Side Cover*. (p.160)
2. Remove the *L Side Cover*. (p.163)
3. Remove the *I/H Cover*. (p.164)
4. Remove the *H Top Cover*. (p.165)
5. While pushing the cutter area gently, shift the carriage to the left about 2 cm to unlock the carriage and then move the carriage to the printer center. (See Figure 4-24)
6. Remove one screw (CPPM3×6) securing the CR Board Guide, and remove three screws (CP(W): M3×6) securing the ground line, washer (M3), and CR Board Guide. (See Figure 4-30)
7. Disconnect the following three connectors on the CR Board. (See Figure 4-31)

Connector Type	Connected to
5-Pin (white)	CR Encoder Sensor
4-Pin (black)	P_EDGE Sensor
2-Pin (white)	Cutter Solenoid

8. Remove the four screws (CP(W): M3×8) securing the Cutter Holder, and while paying attention to the connector harness connected to the CR Board, remove the Cutter Holder ASSY from the carriage. (See Figure 4-33)



The cutter cap and the CR lock kicker should be engaged. (If they are not engaged, the carriage cannot be moved from the home position to the left when the power switch is turned on.) (See Figure 4-34)

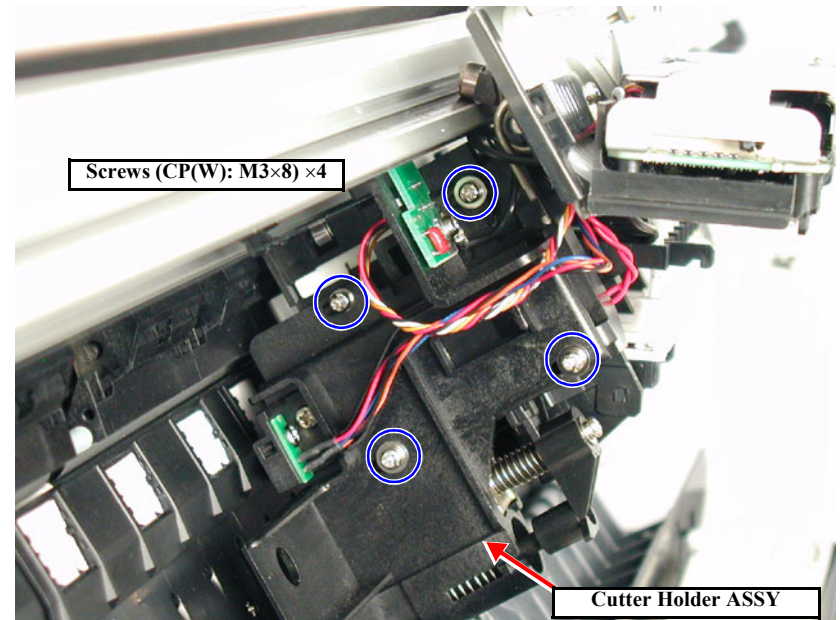

Figure 4-33. Removing the Cutter Housing

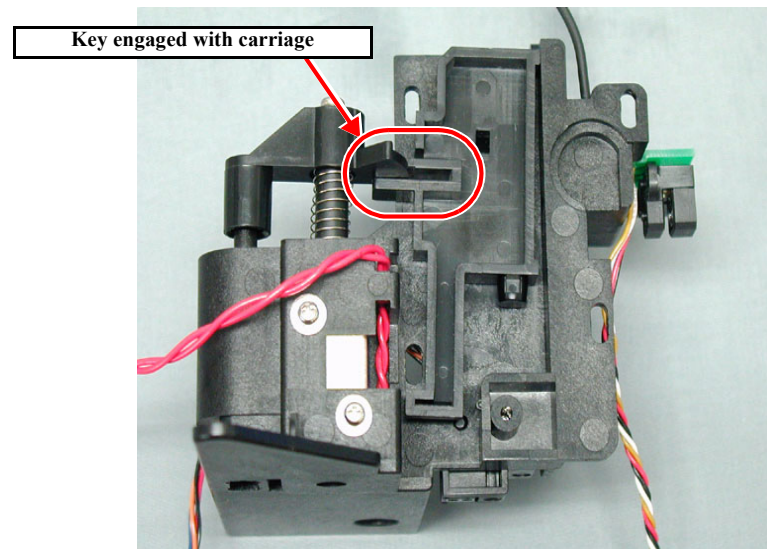
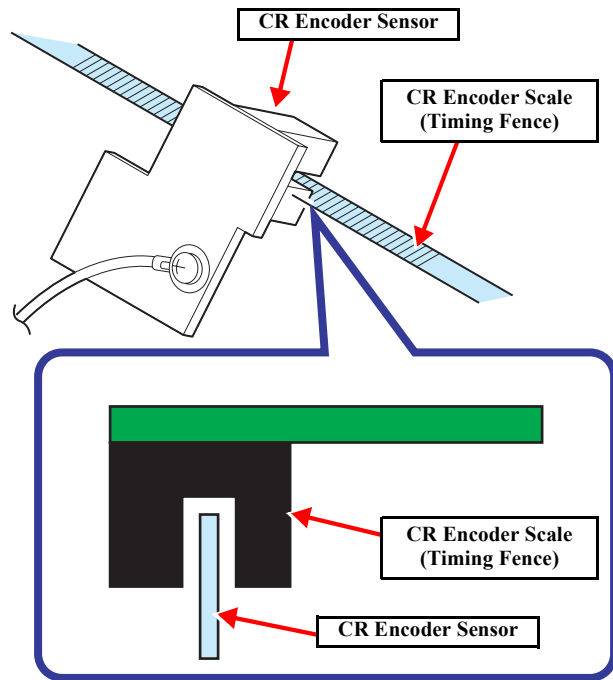

Figure 4-34. Cutter Holder ASSY (Back: Carriage Side)



- Take care not to catch the solenoid cable (red) in the cutter cap. (See Figure 4-35)
- When installing the Cutter Holder ASSY, make sure that the CR Encoder Scale (Timing Fence) is led through the slit in the CR Encoder Sensor properly.



Me_Cutt09.eps

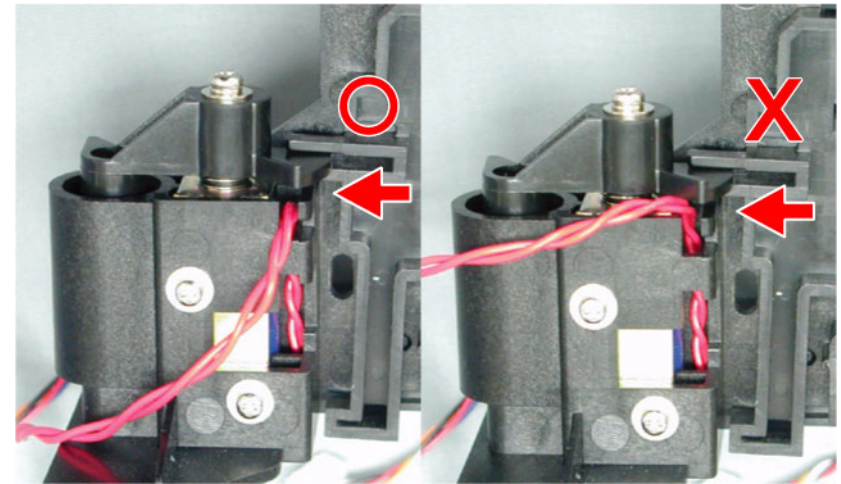

Figure 4-35. Take Care When Installing the Cutter Holder

ADJUSTMENT
REQUIRED



After installing the cutter holder ASSY, the following adjustment should be done.

- “5.1.4.11 Cutter Solenoid ASSY or Paper Guide L Adjustment (p.217)”

4.3.4.2 Cutter Solenoid

1. Remove the *Cutter Holder ASSY*. (p.175)
2. Release the engagement between the Cutter Cap and the CR Lock Kicker, then remove the Cutter Cap + Cutter Solenoid Iron Core and Cutter Solenoid Spring.
3. Take out the two screws (CP(W): M3×6) holding the Cutter Solenoid, then remove the Cutter Solenoid by pushing it out from the bottom of the Cutter Holder ASSY with the shaft of a (+) screwdriver or the like.



Do not pull the cable to remove the Cutter Solenoid.



After installing the Cutter Solenoid, the following adjustment should be done.

- *“5.1.4.11 Cutter Solenoid ASSY or Paper Guide L Adjustment (p.217)”*

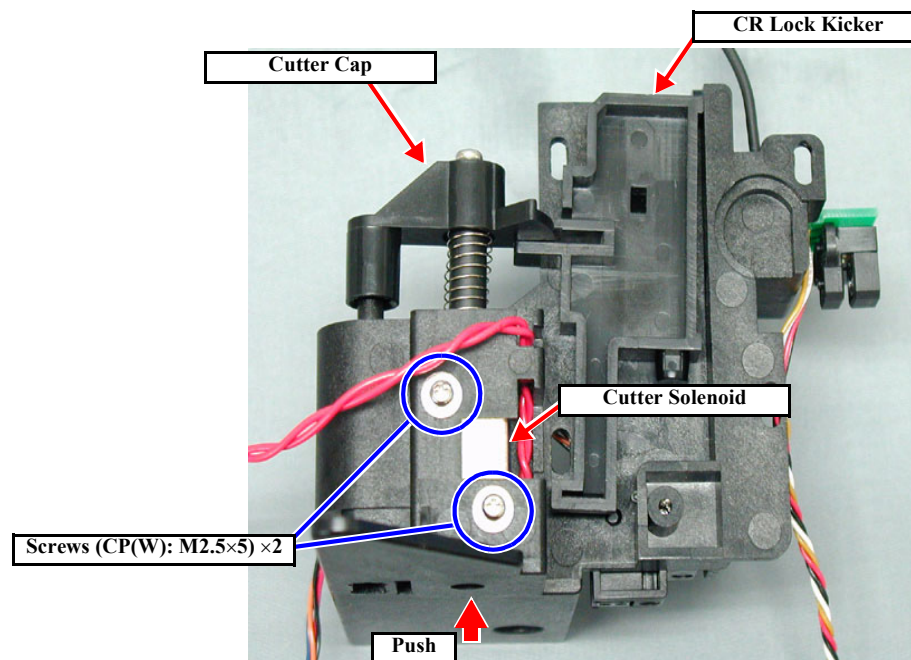

Figure 4-36. Cutter Solenoid Removal

4.3.5 CR Encoder Sensor ASSY

1. Remove the *R Side Cover*. (p.160)
2. Remove the *L Side Cover*. (p.163)
3. Remove the *I/H Cover*. (p.164)
4. Remove the *H Top Cover*. (p.165)
5. Remove one screw (CPP M3×6), two screws (CP(W): M3×6) and one screw (M3×16) securing the CR Board Guide, and also the ground line and the toothed washer (M3), and remove the CR Board Guide. (See Figure 4-30)
6. Disconnect the connector (5-pin, white) for the CR Encoder Sensor from the CR Board.

CAUTION

If you can not disconnect easily the connector for the CR Encoder Sensor, do not disconnect it by undue force. Disconnect the two FFCs for the print head first and then the connector for the CR Encoder Sensor.

7. Remove the two screws securing the CR Board Unit in the Carriage Unit, and take out the CR Board Unit toward the front. (See Figure 4-37)
8. Remove one screw (CPP: M3×8) securing the CR_ENC ASSY, ground line, and washer (M3). Then remove the CR_ENC ASSY. (See Figure 4-38)

**ADJUSTMENT
REQUIRED**

After assembling the CR ENC, the following adjustments should be made.

- “5.1.4.8 CR Encoder Sensor ASSY Adjustment (p.215)”

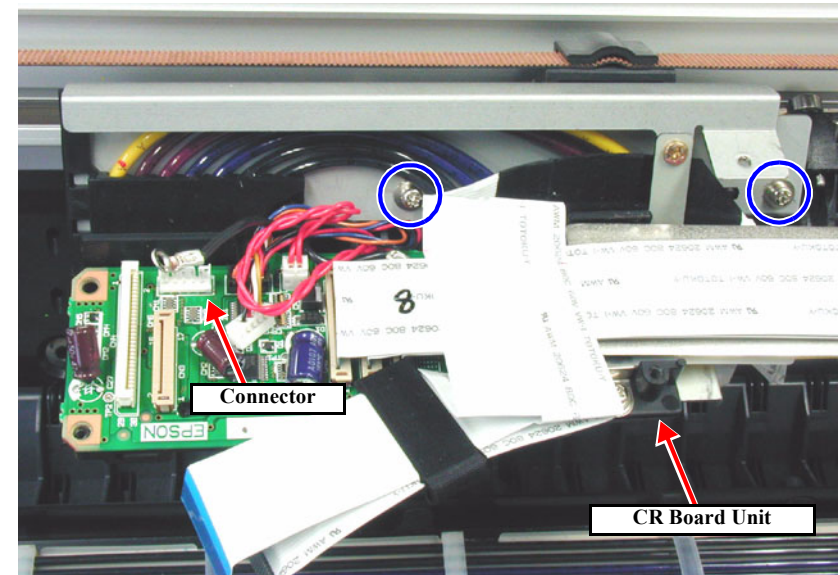

Figure 4-37. CR Encoder Sensor Removal 1/2

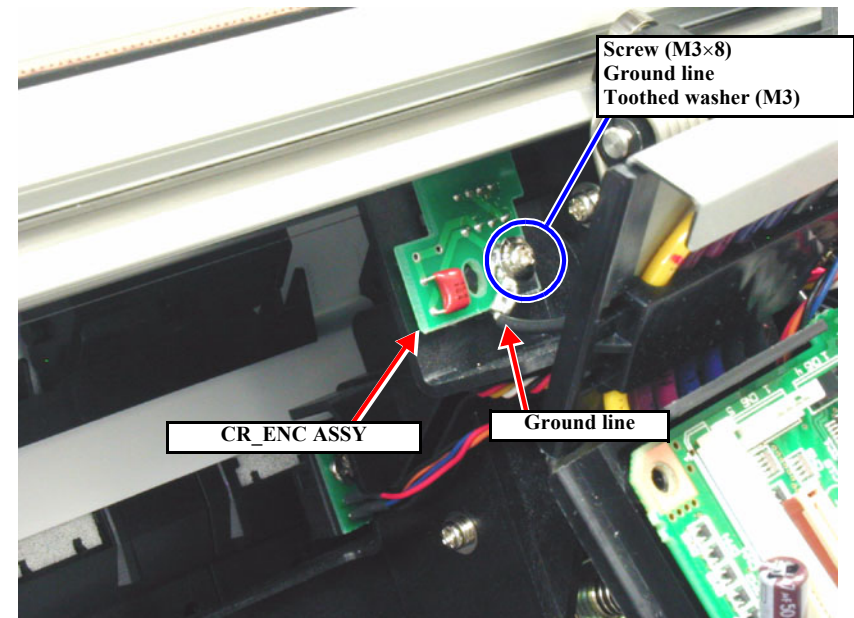

Figure 4-38. CR Encoder Sensor Removal 2/2

4.3.6 P_EDGE Sensor ASSY

1. Remove the R Side Cover. (p.160)
2. Remove the L Side Cover. (p.163)
3. Remove the I/H Cover. (p.164)
4. Remove the H Top Cover. (p.165)
5. Remove one screw (CPP M3×6), two screws (CP(W): M3×6) and one screw (M3×16) securing the CR Board Guide, and also the ground line and the toothed washer (M3), and remove the CR Board Guide. (See Figure 4-30)
6. Disconnect the connector (4-pin, black) for the P_EDGE Sensor from the CR Board.



If you can not disconnect easily the connector for the P_EDGE Sensor, do not disconnect it by undue force. Disconnect the two FFCs for the print head first and then the connector for the P_EDGE Sensor.

7. Remove the two screws securing the CR Board Unit in the Carriage Unit, and take out the CR Board Unit toward the front. (See Figure 4-39)
8. Remove the one screw (M3×6) securing the EDGE Sensor Base ASSY and remove the EDGE Sensor Base ASSY. (See Figure 4-40)



After installing the P_EDGE Sensor ASSY on the Cutter Holder ASSY, fasten the harness to the harness holding path of the Cutter Holder ASSY.
(See Figure 4-40)



After replacing the P_EDGE Sensor, the following adjustment operation should be performed.
 ■ **“P_EDGE Sensor ASSY Adjustment (p.215)”**

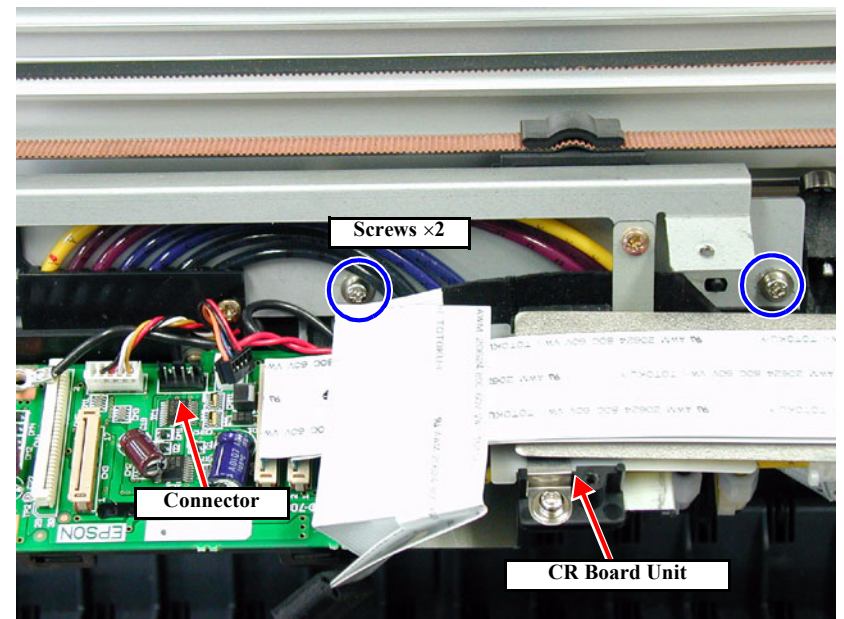

Figure 4-39. Removing the P_EDGE Sensor ASSY 1/2

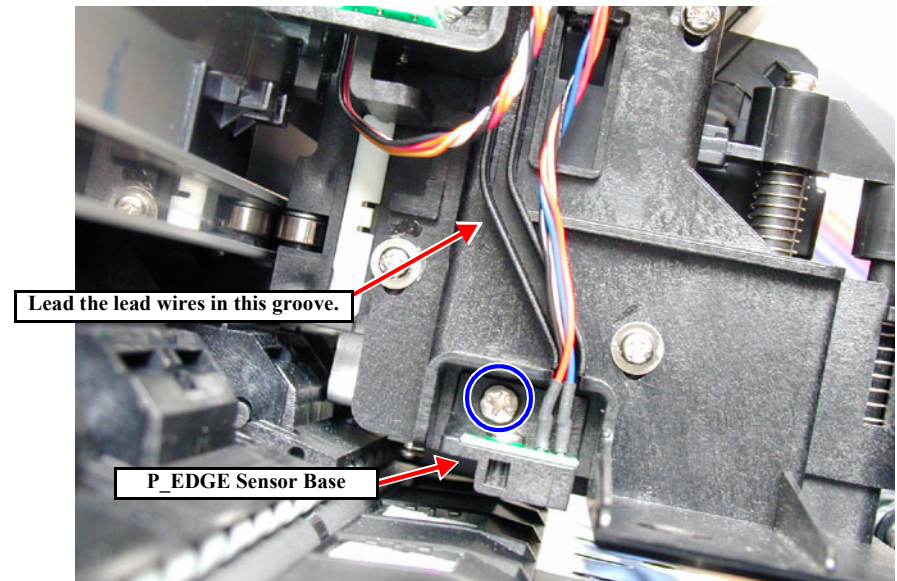

Figure 4-40. Removing the P_EDGE Sensor ASSY 2/2

4.3.7 CR Motor ASSY

This section describes the replacement procedure for the following parts of the CR Motor ASSY.

- CR Timing Belt
- Driven Pulley

(Stylus Pro 7600: white / Stylus Pro 9600: black)



Before installing the covers, adjust the indicator position (the right end of the projection on the CR tension spring support) of the CR tension bracket to the center by turning the CR Tension Mounting Shaft.

However, if the indicator was at a off-center position before assembly, adjust the indicator to the same off-center position. (See Figure 4-42)

1. Remove the R Side Cover. (p.160)
2. Remove the L Side Cover. (p.163)
3. Remove the I/H Cover. (p.164)
4. Remove the H Top Cover. (p.165)
5. Release the carriage lock and move the carriage from the capping position. (See Figure 4-24)
6. On the R Side Frame side, remove the CR Tension Mounting Shaft and CR Tension Spring and the CR Tension Spring Support. (See Figure 4-42)
7. Slide the CR Tension Bracket to the left (toward the CR Motor), and remove the CR Timing Belt, together with the Driven Pulley, from the CR Tension Bracket.

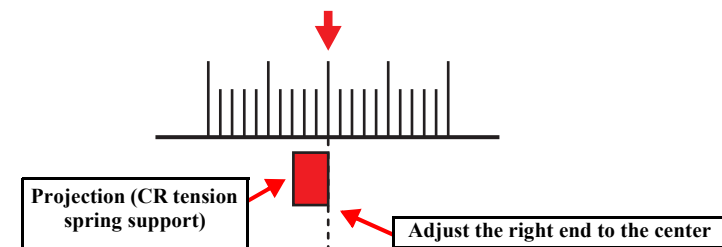
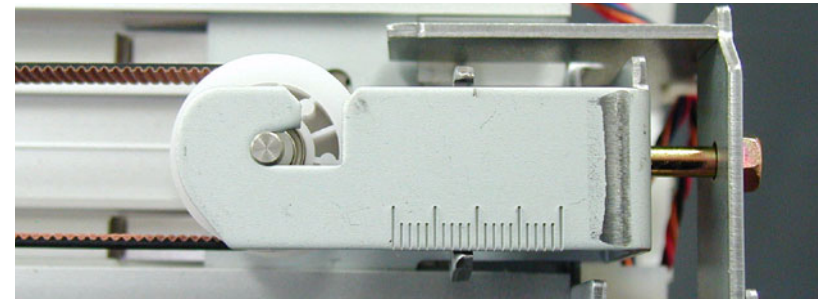

Figure 4-41. Indicator Position

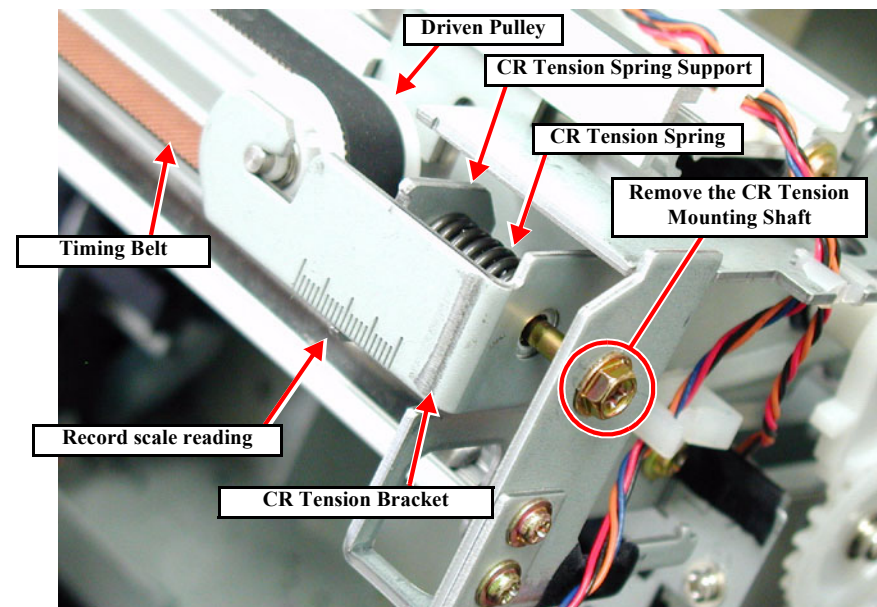

Figure 4-42. Loosening the CR Timing Belt

8. Loosen the CR Tension Mounting Shaft on the R Side Frame side, then release the tension on the CR Timing Belt. (See Figure 4-43)
9. Disconnect the connector of the CR Motor harness and the relay connector from the Main Board, unclamp the CR Motor harness and take them out through the hole in the Left Side Frame.
10. Remove the timing belt from the CR Motor ASSY pulley on the L Side Frame.
11. Take out the four screws (CP(W): M4×10) holding the CR Motor ASSY, then remove the CR Motor ASSY.

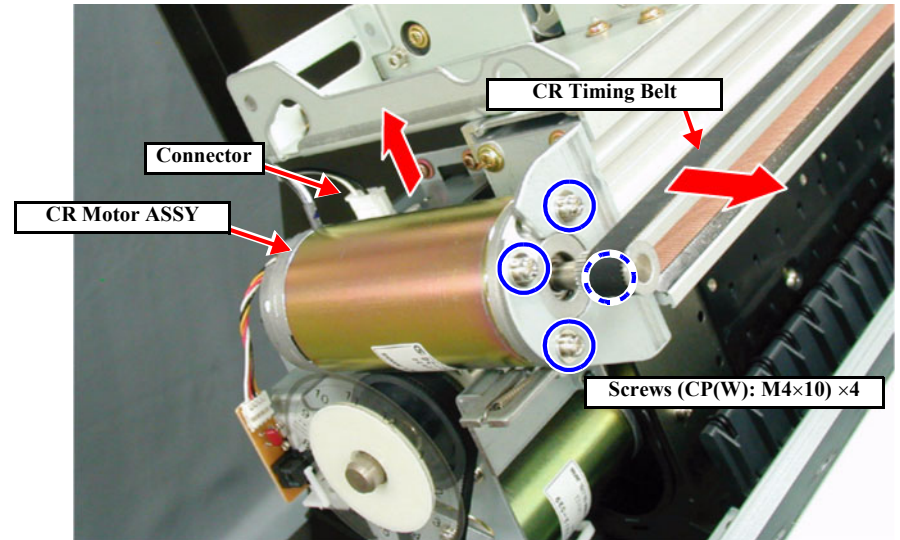
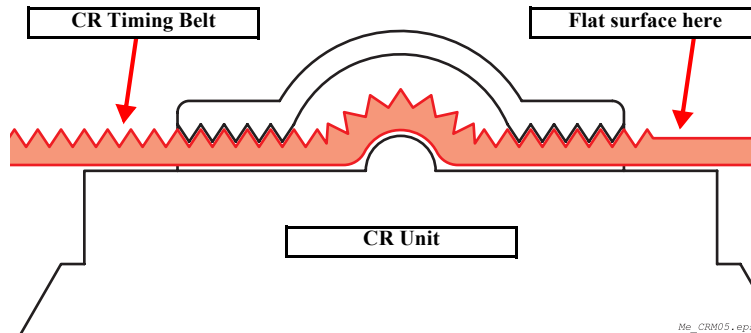

Figure 4-43. Removing the CR Motor ASSY

REASSEMBLY



- Remember that there is a difference in specifications between the driven pulley (white) of Stylus Pro 7600 and the driven pulley (black) of Stylus Pro 9600.
- Set the timing belt of Stylus Pro 7600 on the CR Unit in a manner as shown below:



- Install the timing belt by adjusting the tension on the driven pulley side, with the CR Motor secured with the screws. Installing the timing belt by adjusting the tension on the CR Motor side could damage the PF Encoder Scale.
- Move the carriage by hand to the left and right and make sure that the CR Timing Belt is attached uniformly in the center of the pulley.

ADJUSTMENT REQUIRED



Once the belt tension has changed as a result of, say, removal of the CR Motor, make the following adjustment:

- “5.1.4.3 CR Motor Adjustment” (p.214)

4.3.8 HEAD_SLIDE Sensor ASSY

CAUTION

When unlocking the carriage, do not move the carriage by about 2 cm or more with the cutter pushed into the innermost position; otherwise, the cutter edge would be damaged.

1. Remove the R Side Cover. (p.160)
2. Remove the Access Cover. (See *Removing the Access Cover on page 167*)
3. While pushing the cutter area gently, shift the carriage to the left about 2 cm to unlock the carriage and then move the carriage to the left from the capping position. (See *Figure 4-24*)
4. Disconnect the connector (CN29: red 4-pin) of the HEAD_SLIDE Sensor ASSY from the Main Board and take it out through the hole in the R Side Frame.
5. Remove the one (CP(W): M3×6) screw securing the HEAD_SLIDE Sensor ASSY and remove the HEAD_SLIDE Sensor ASSY. (See *Figure 4-44*)
6. Release the harness for the HEAD_SLIDE Sensor ASSY from the five cable clamps on the Maintenance ASSY and CR Rail ASSY. (See *Figure 4-45*)

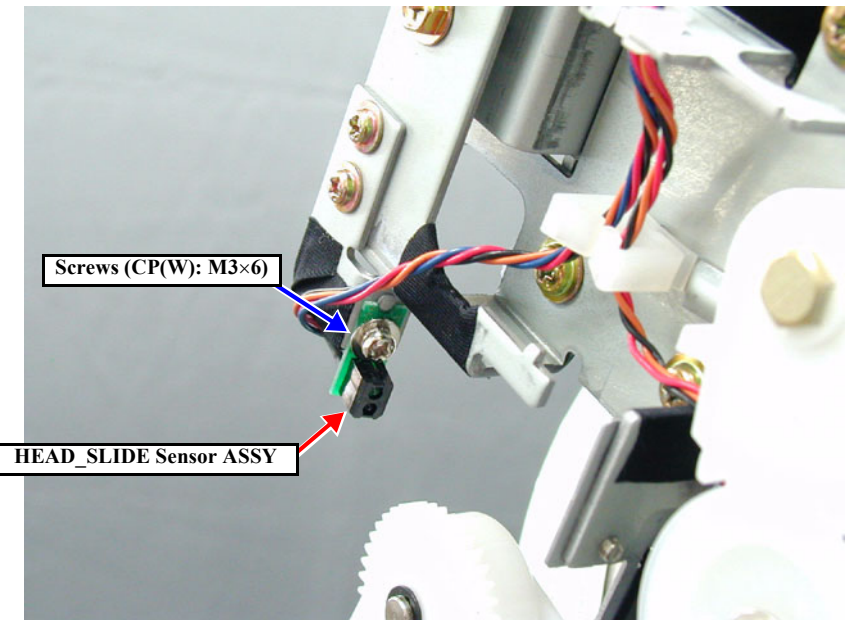

Figure 4-44. Removing the HEAD_SLIDE Sensor ASSY

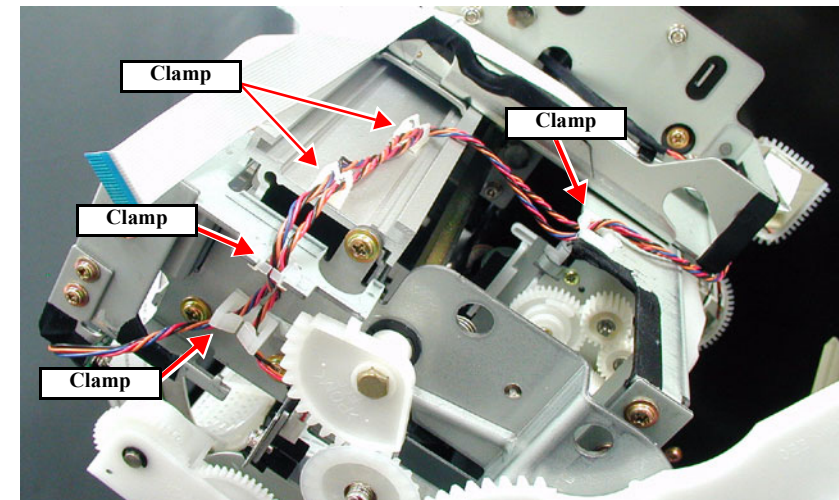

Figure 4-45. Releasing the HEAD_SLIDE Sensor ASSY Harness

4.3.9 CR_HP Sensor ASSY

CAUTION

When unlocking the carriage, do not move the carriage by about 2 cm or more with the cutter pushed into the innermost position; otherwise, the cutter edge would be damaged.

1. Remove the *R Side Cover*. (p.160)
2. While pushing the cutter area gently, shift the carriage to the left about 2 cm to unlock the carriage and then move the carriage to the left from the capping position. (See Figure 4-24)
3. Release the harness of the CR_HP Sensor ASSY from the four clamps on the printer body. (See Figure 4-46)
4. Pinch the two upper hooks of the CR_HP Sensor ASSY and disengage them from the holding plate, and disconnect the connector. (See Figure 4-47)

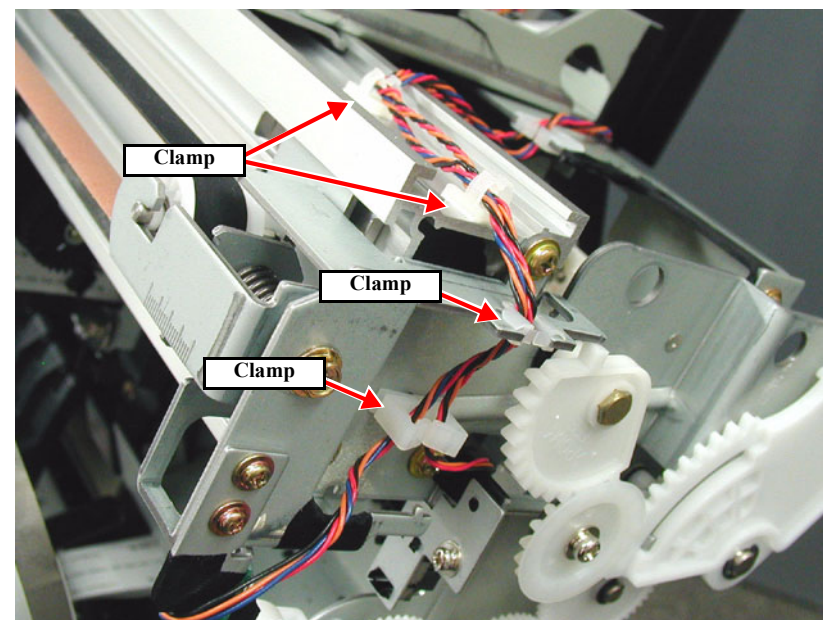

Figure 4-46. Releasing the CR_HP Sensor ASSY Harness

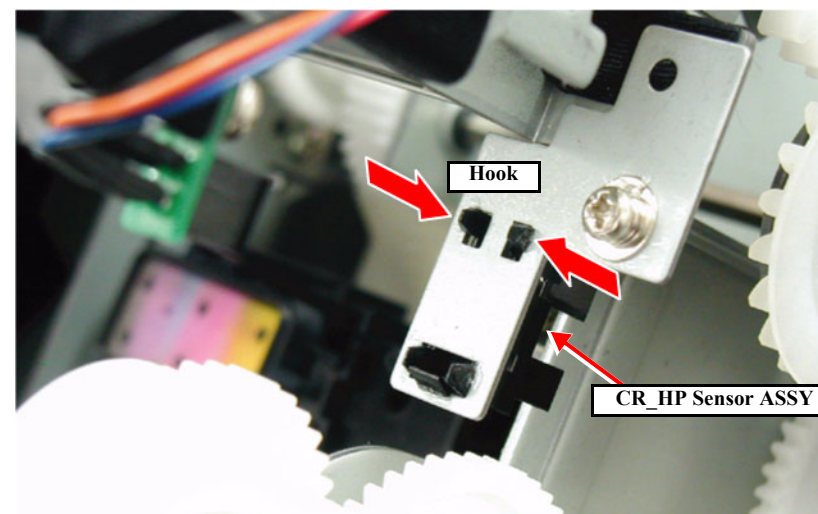

Figure 4-47. Removing the CR_HP Sensor

4.3.10 CR Encoder Scale (Timing Fence)

CAUTION

- When unlocking the carriage, do not move the carriage by about 2 cm or more with the cutter pushed into the innermost position; otherwise, the cutter edge would be damaged.
- Take great care not to scratch the CR Encoder Scale. (If the CR Encoder Scale is scratched, the encoder sensor will output wrong signals, thus resulting in abnormal operation of the carriage or error occurrence.)

1. Remove the R Side Cover. (p.160)
2. Remove the L Side Cover. (p.163)
3. Remove the I/H Cover. (p.164)
4. Remove the H Top Cover. (p.165)
5. Remove the CR Encoder Sensor ASSY. (p.178)
6. Disengage the CR Encoder Scale (Timing Fence) from the CR Encoder Scale Fastening Spring on the L Side Frame side.
7. Remove the CR Encoder Scale from the CR Encoder Scale Holders.

NOTE: The number of CR Encoder Scale Holders is as follows:

Stylus Pro 7600: 2 guides

Stylus Pro 9600: 3 guides

8. While pushing the cutter area gently, shift the carriage to the left about 2 cm to unlock the carriage and then move the carriage to the left from the capping position. (See Figure 4-24)
9. Disengage the CR Encoder Scale from the hook on the CR Encoder Scale Holder R and draw out the CR Encoder Scale from the carriage area.

**ADJUSTMENT
REQUIRED**

After assembling the CR ENC, the following adjustments should be made.

- “5.1.4.8 CR Encoder Sensor ASSY Adjustment (p.215)”

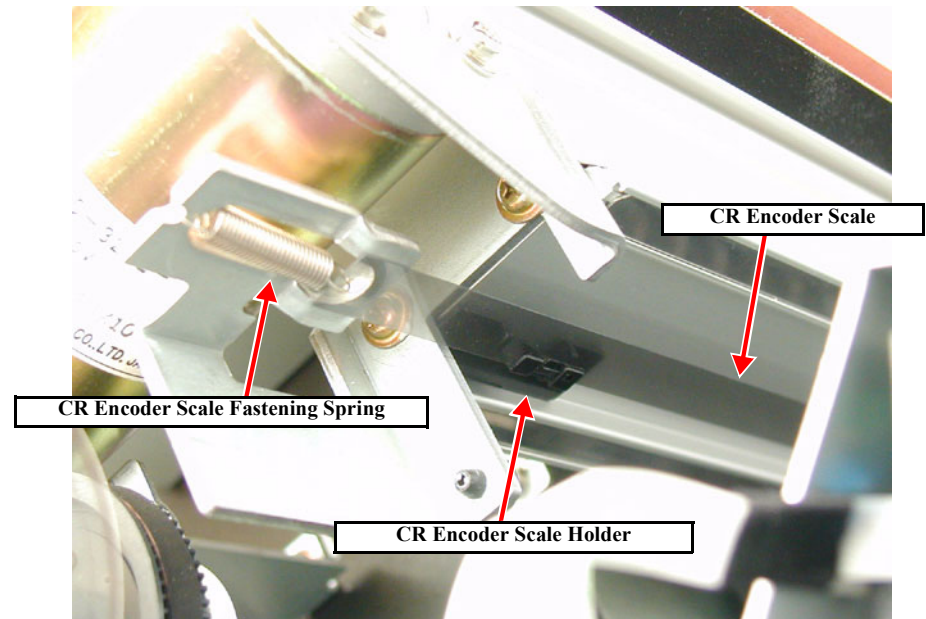

Figure 4-48. Releasing from the CR Encoder Scale Fastening Spring

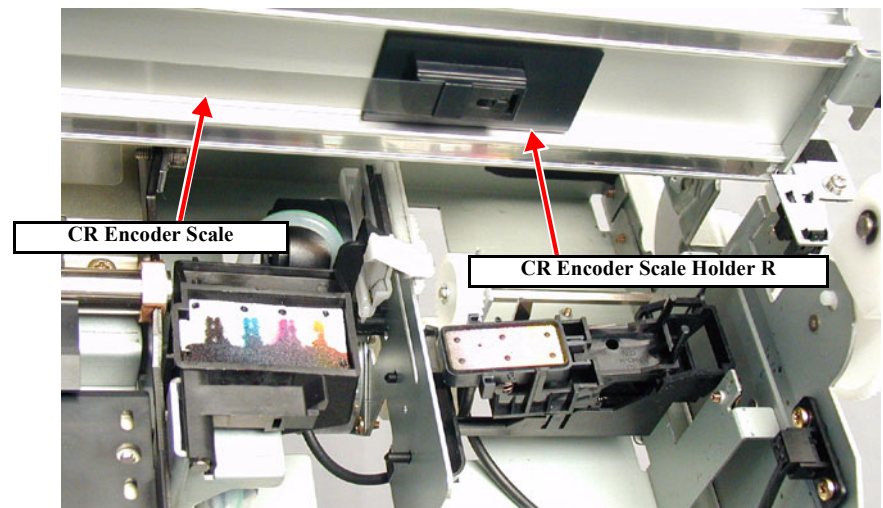

Figure 4-49. CR Encoder Scale Removal

4.4 Disassembly and Assembly of Paper Feed Mechanism

4.4.1 PF Motor

1. Remove the *L Side Cover*. (p.163)
2. Disconnect the one connector cable of the PF Motor ASSY and take it out through the hole in the L Side Frame. (See Figure 4-50)
3. Remove the four screws securing the PF Motor Mounting Plate. (See Figure 4-51)
4. Move the PF Motor toward the printer body and remove the PF Motor by lifting the gear side.

ADJUSTMENT
REQUIRED



After replacing the P_EDGE Sensor, the following adjustment operation should be performed.

- “PF Motor Adjustment (p.214)”

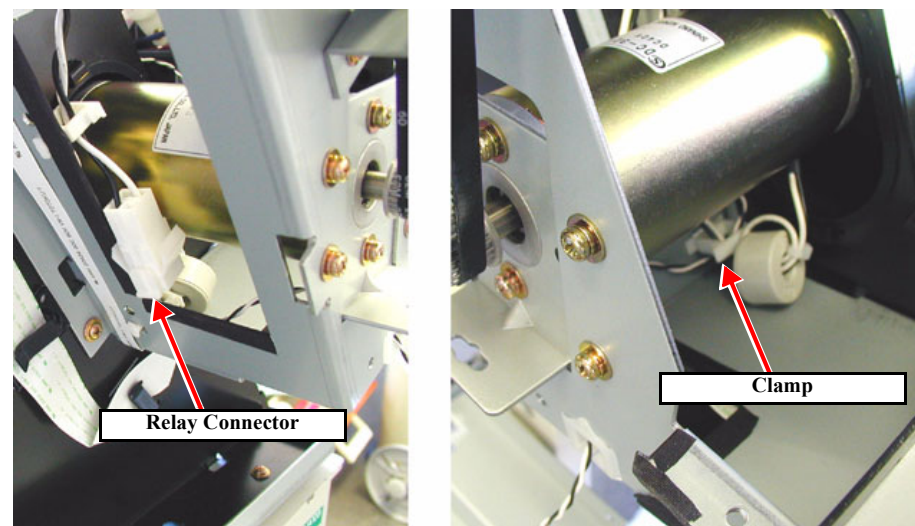

Figure 4-50. Removing the PF Motor ASSY Harness Connector.

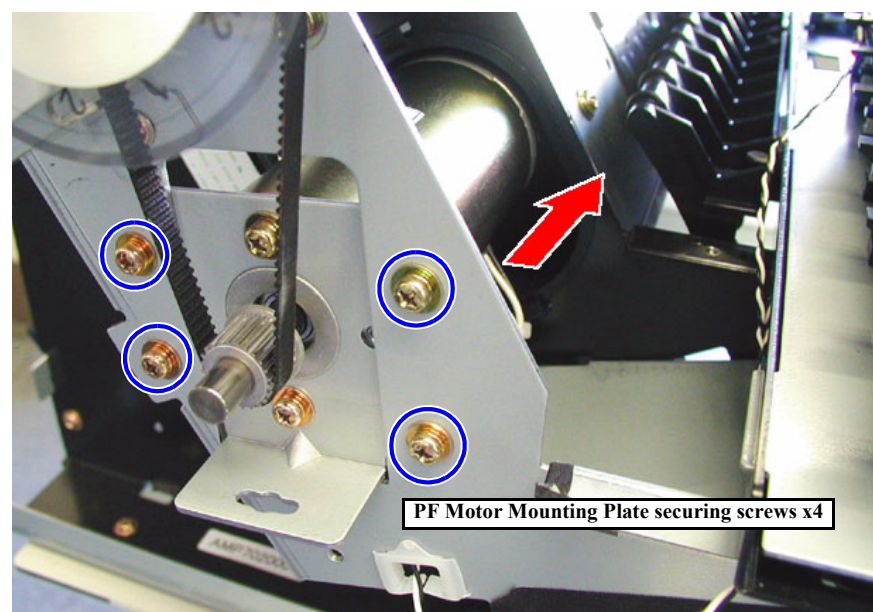

Figure 4-51. Removing the PF Motor.

4.4.2 PF Encoder Sensor ASSY

1. Remove the *L Side Cover*. (p.163)
2. Disconnect the PF Encoder Sensor connector.
3. Remove the one screw securing the PF Encoder Sensor and remove the PF Encoder Sensor ASSY.

ADJUSTMENT
REQUIRED



After installing the PF Encoder Sensor ASSY, make the following adjustment.

- *“5.1.4.10 PF Encoder Sensor ASSY Adjustment (p.216)”*

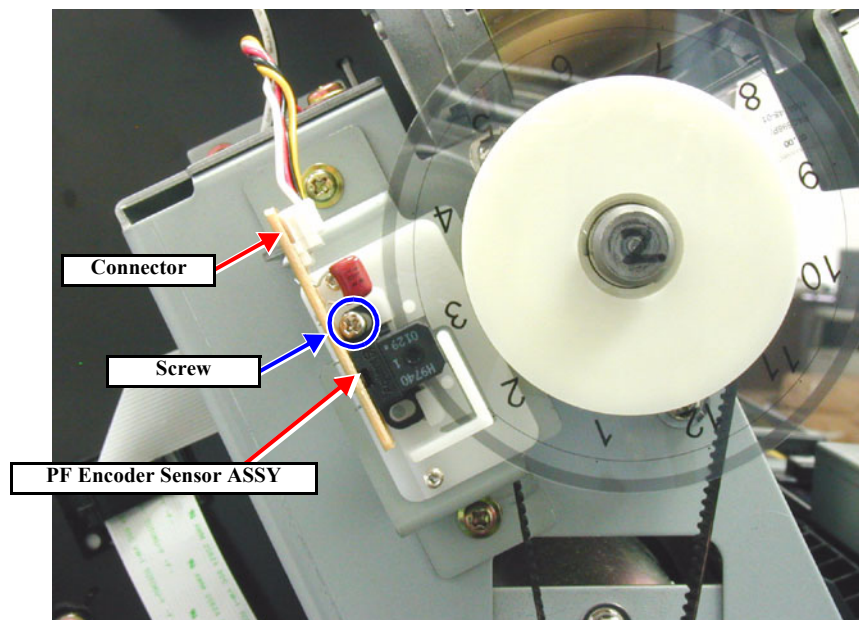

Figure 4-52. Removing the PF Encoder Sensor.

4.4.3 Cautions when replacing the PF Loop Scale

4.4.3.1 Assembly Procedure for the PF Loop Scale ASSY

When assembling the PF loop scale unit, the following exclusive tool should be used.

- Exclusive tool No.#F730 : FPF Loop Scale Assembly Base (Code: 1051765)

The assembly procedure is shown below.

1. Set the exclusive tool, #F730 as shown in the figure below, then set the PF loop scale base part with the double sided tape side facing up.
2. Peel the protective backing off the double sided tape to the PF loop scale base.
3. Affix the PF loop scale carefully to the PF loop scale base with the PF loop scale printed surface downward, aligning it precisely with the PF loop scale base.
4. Peel the protective backing off the other side of the double sided tape and affix the tape so that it is within the black circle on the unprinted side of the PF loop scale ASSY.



- Care should be taken so as not to damage the internal diameter of the PF loop scale.
- There is no problem if the PF loop scale's affixing position on the PF loop scale base deviates somewhat. The important control point is that the inside diameter of the PF loop scale not be damaged.

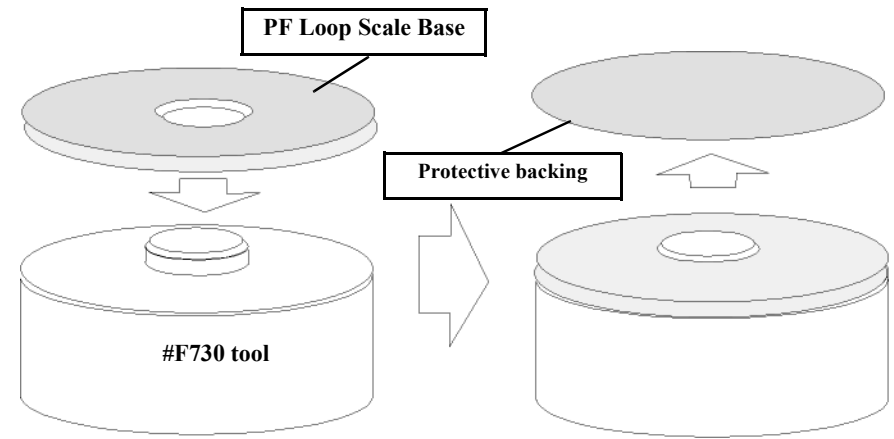

Figure 4-53. #F730 tool and PF Loop Scale Base

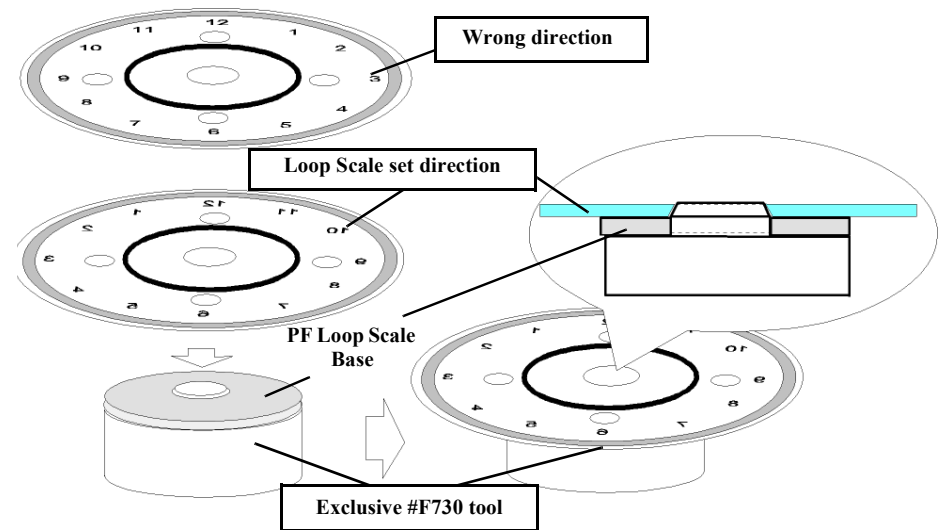

Figure 4-54. PF Loop Scale Set

4.4.3.2 PF Loop Scale ASSY Affixing Procedure

When assembling the PF loop scale unit, the following exclusive tool should be used.

- Exclusive tool No.#F731 : PF Loop Scale Affixing tool
(Code: 1051767)

The assembly procedure is given below.

1. Set the PF loop scale ASSY's double sided tape side on the grid roller side, align the internal diameter of the PF loop scale with the left end of the grid roller (PF roller) and set it lightly.

CAUTION



At this point, the PF loop scale ASSY should not be fitted on the grid roller as far as it can go. If the PF loop scale ASSY is placed on the grid roller by hand, it could damage the PF loop scale ASSY's internal diameter and the distance from the center of the grid roller to the scale reading part would not be the same all around any more, resulting in a drop in the encoder sensor's reading accuracy.

2. Press the exclusive tool #F731 against the PF loop scale ASSY from the outside, then insert the grid roller in as far as the base plate carefully, and affix it.

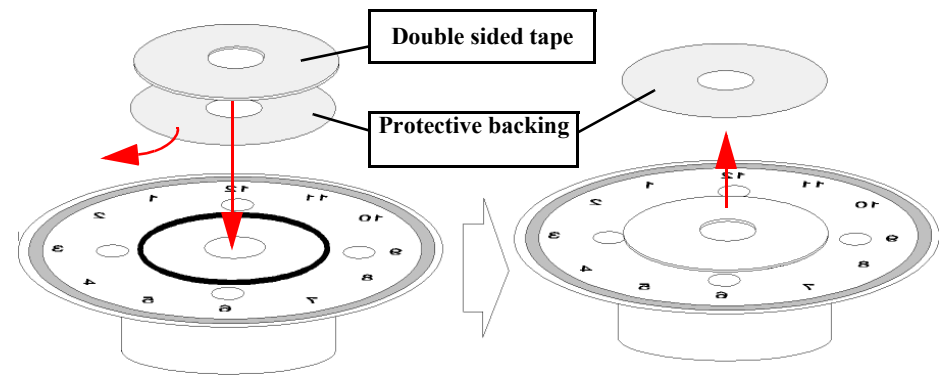

Figure 4-55. Affixing the Double Sided Tape to the PF Loop Scale

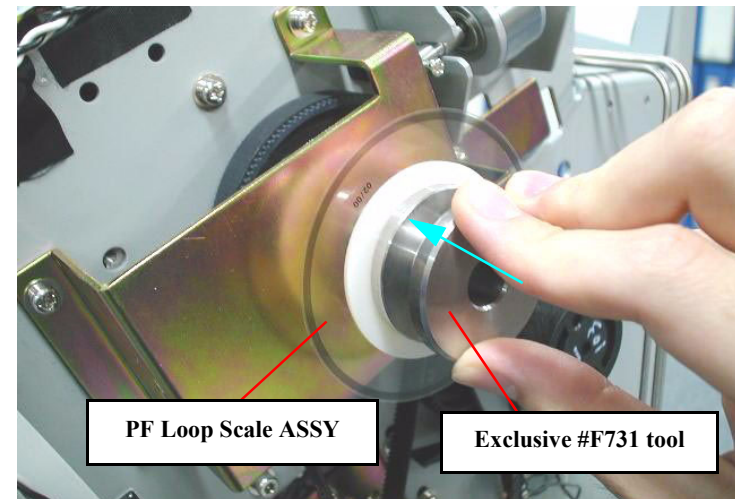

Figure 4-56. Affixing the PF Loop Scale ASSY

4.4.4 Suction Fans

1. Remove the *Paper Guide L2*. (p.168)
2. Remove the two screws (CP(W): M4×8) and one screw (CP(W): M4×40) securing the fan duct, and then remove the fan duct.
3. Disconnect the fan connector and harness.
4. Remove the one screw (CP(W): M4×8) securing the fan, and remove the fan.

NOTE: The number of fans:
 Stylus Pro 7600: 2
 Stylus Pro 9600: 3

CHECK POINT

When removing the right-side Suction Fan of Stylus Pro 7600, use a short Phillips screwdriver to avoid interference with the Maintenance Tank Holder.

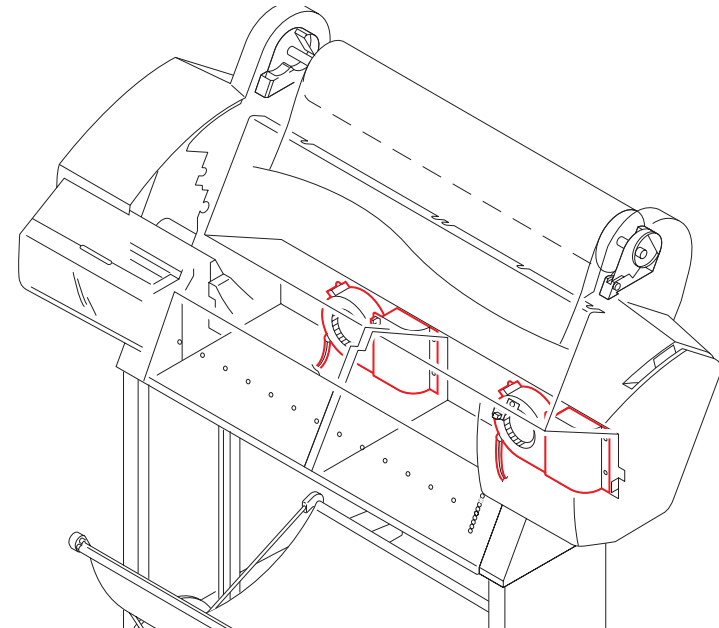

Me_Fan10.eps

Figure 4-57. Suction Fan Mounting Position

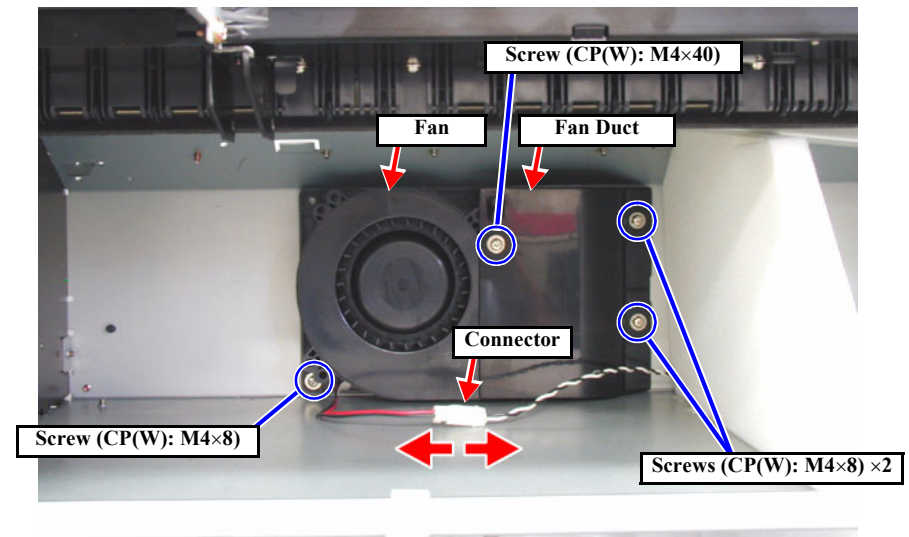

Figure 4-58. Suction Fan Removal

4.4.5 P_THICK Sensor/P_THICK Sensor_0.3 ASSY

- P_THICK Sensor ASSY
- P_THICK_0.3 Sensor ASSY

1. Remove the *R Side Cover*. (p.160)
2. Remove the *L Side Cover*. (p.163)
3. Remove the *I/H Cover*. (p.164)
4. Remove the *H Top Cover*. (p.165)
5. Push the paper hold lever down to the rear.
6. Remove the harness from the connector of the P_THICK Sensor/P_THICK_0.3 Sensor.
7. Remove the one (CUPS: M3×6) screw securing the sensor bracket and remove the bracket along with the both sensors.

**CHECK
POINT**



Sensor bracket position is adjusted at the factory before shipment. When the sensor bracket is to be removed on the service site, you are advised to mark the mounting position before removal for easy adjustment at reassembly.

8. Unhook the sensor from the sensor bracket and remove the sensor.

**ADJUSTMENT
REQUIRED**



If you move the sensor bracket position, perform the necessary adjustment.

- Refer to “5.1.4.7 P_THICK/P_THICK_0.3 Sensor ASSY Adjustment” (p.215)

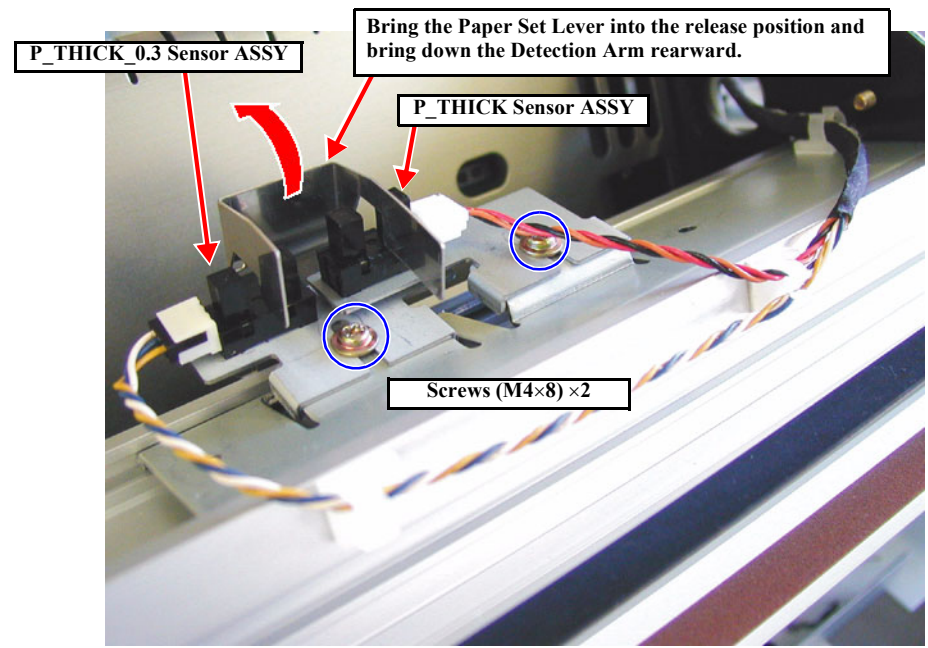

Figure 4-59. P_THICK and P_THICK_0.3 Sensors Removal

4.4.6 P_REAR Sensor ASSY

1. Remove the R Side Cover. (p.160)
2. Remove the L Side Cover. (p.163)
3. Remove the I/H Cover. (p.164)
4. Remove the H Top Cover. (p.165)
5. Remove the Rear Cover. (p.166)
6. Disconnect the connector (CN27: black 4-pin) of the P_REAR Sensor ASSY from the Main Board.
7. Push the Paper Hold Lever down to the front.
8. Remove the lower two screws (CBS: M4×6) securing the Paper Guide U.
(See Figure 4-60)
9. Remove the upper three screws (CBS: M4 × 6) (six screws for Stylus Pro 7600) securing the Paper Guide U and remove the Paper Guide U by pulling it up toward you slowly.



When removing/installing the Paper Guide U, be careful not to mar the P_REAR Sensor ASSY with the edge of the sensor inspection window.

10. Remove the two (CP(W): M2×8) screws securing the P_REAR Sensor ASSY and remove the P_REAR Sensor ASSY. (See Figure 4-61)



The P_REAR Sensor ASSY position is adjusted at the factory before shipment. When the sensor bracket is to be removed on the service site, you are advised to mark the mounting position before removal for easy adjustment at reassembly.



If you replace the P_REAR Sensor ASSY, perform the necessary adjustment.

- Refer to “5.1.4.6 P_REAR Sensor ASSY Adjustment” (p.215)

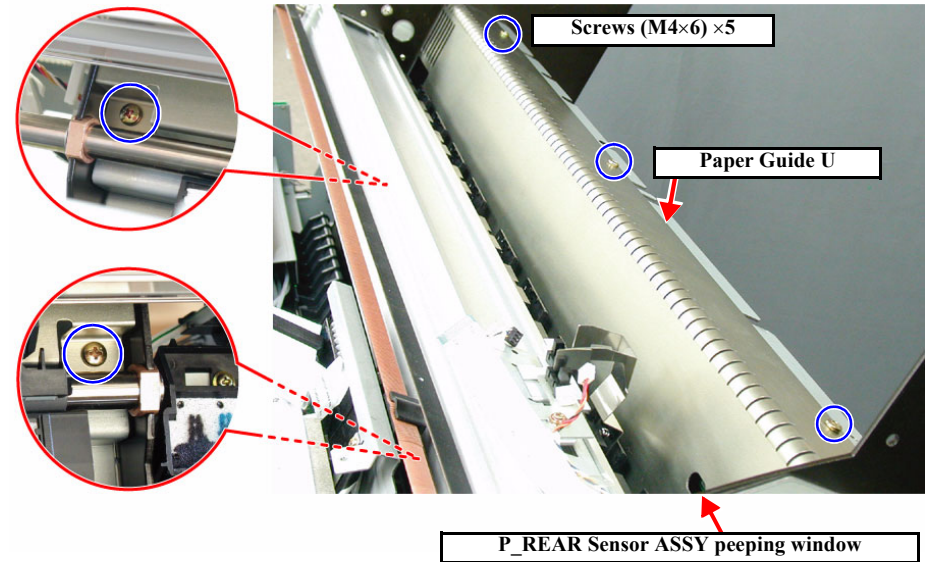

Figure 4-60. Removing the Paper Guide U

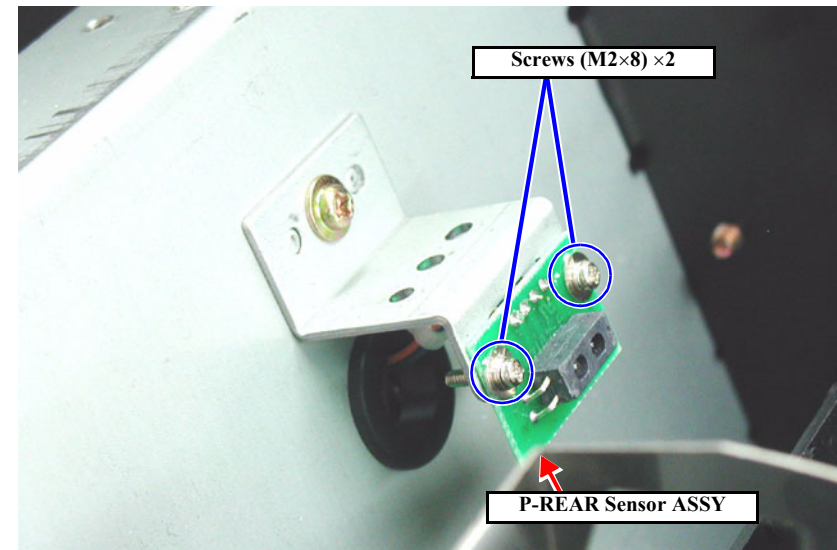

Figure 4-61. Removing the P_REAR Sensor ASSY

4.5 Disassembly and Assembly of Ink Supply Mechanism

4.5.1 C472_SUB-B Board

1. Remove the *L Side Cover*. (p.163)
2. Disconnect the seven FFCs (ink cartridge) and the two FFCs (Main Board/Maintenance Tank) on the C472_SUB-B Board found at the left side of I/H Frame. (See Figure 4-62)
3. Disconnect the connector of the Release Sensor (I/H Lever).
4. Remove the four screws (M3×6) and remove the C472_SUB-B Board.

CAUTION

When connecting an FFC, take great care not to insert it aslant. (Inserting aslant can cause a short circuit of signals, thus resulting in broken circuit elements.)

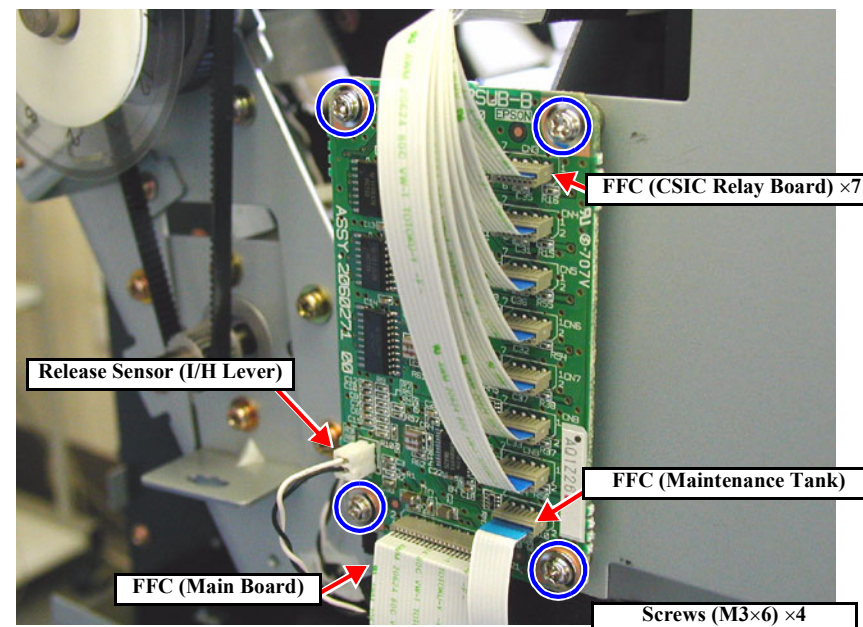

Figure 4-62. Disconnecting the C472_SUB-B Board Connectors

4.5.2 I/H (Ink Holder) ASSY

There are a total of seven I/H assemblies installed, one for each ink color. Here, the procedure for removing one I/H ASSY will be explained.

This section also describes the procedure for removing the following parts:

- Release Sensor (I/H Lever)
- CSIC Relay Board
- I/H Frame

CAUTION



You must execute ink discharge (“*Ink Blowing*” in 5.2.3.20 *Clean Head on page 256*) before removal of the I/H ASSY and ink charging (“*Initial charge*” in 5.2.4 *Cleaning on page 259*) after reinstallation. If no ink tube is to be removed, there is no need of executing ink discharge.

ADJUSTMENT REQUIRED



When removing and installing the front cover switch holder, the following adjustment should be made.

- Refer to “5.1.4.9 *Cover Sensor ASSY Adjustment*” (p.216)

1. Remove the *R Side Cover*. (p.160)
2. Remove the *L Side Cover*. (p.163)
3. Remove the *I/H Cover*. (p.164)
4. Remove the *H Top Cover*. (p.165)
5. Disconnect the seven FFCs (ink cartridges), two FFCs (Main Board/Maintenance Tank) and the connector for the Release Sensor (I/H Lever) on the C472_SUB-B Board found at the left side of I/H Frame. (See *Figure 4-62*)
6. Remove two black screws (M3×8) securing the Ink Tube Cover and remove the cover. (See *Figure 4-63*)
7. Disconnect the connector of the Cover Sensor ASSY at the right side of the I/H Frame. (See *Figure 4-64*)
8. Remove one screw (CUPS: M3×6) and one screw (CUPS: M4×6) securing the I/H Frame on the right side.

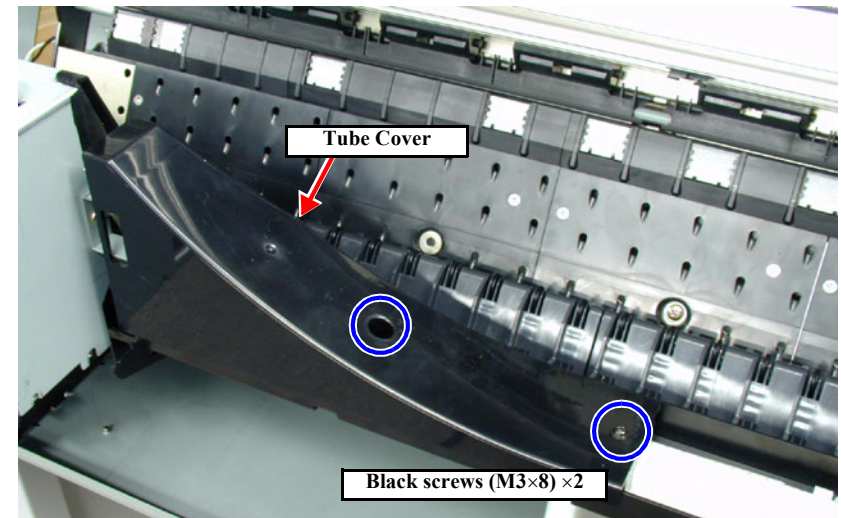

Figure 4-63. Ink Tube Cover Removal

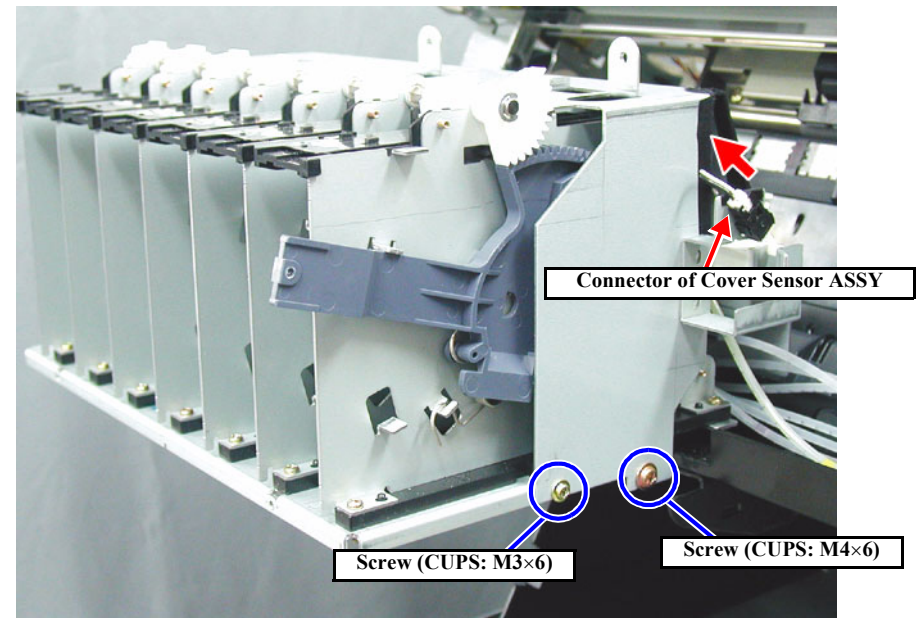
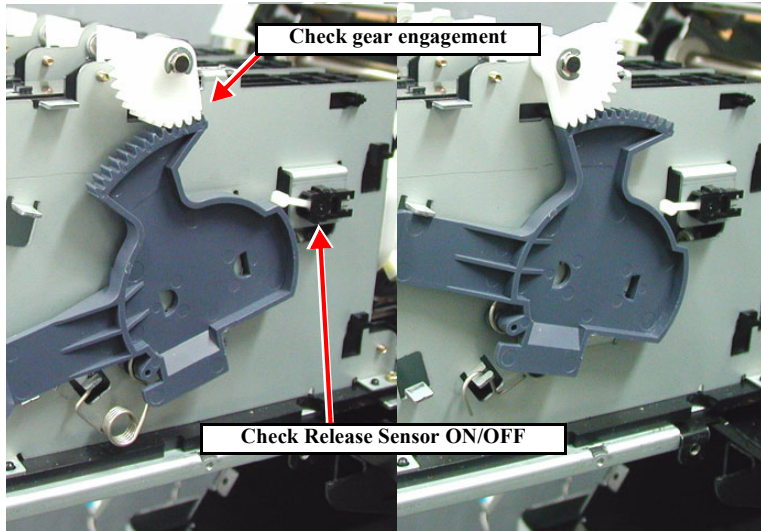

Figure 4-64. I/H Frame Removal 1/2

9. Remove one screw (CUPS: M3×6) and one screw (CUPS: M4×6) securing the I/H Frame on the left side. (See Figure 4-65)
10. Remove seven screws (CUPS: M3×6) and two screws (CUPS: M4×6) securing the I/H Frame on the top.
11. Lift the I/H Frame and disconnect the connector of the Release Sensor (I/H Lever). (See Figure 4-66)
12. Remove the I/H Frame while paying attention to the connectors of the Cover Sensor and Release Sensor (I/H Lever).



■ Before installing the I/H Frame, make certain that the gear of the I/H Lever is engaged with the gear of the Cartridge Lock Shaft and also that the Cover Sensor turns ON and OFF.



■ When installing the I/H Frame, make sure that the projections on the I/H ASSY are fitted in the seven holes in the top plate properly. If the I/H ASSY is not installed properly, the ink cartridges may not be recognized.

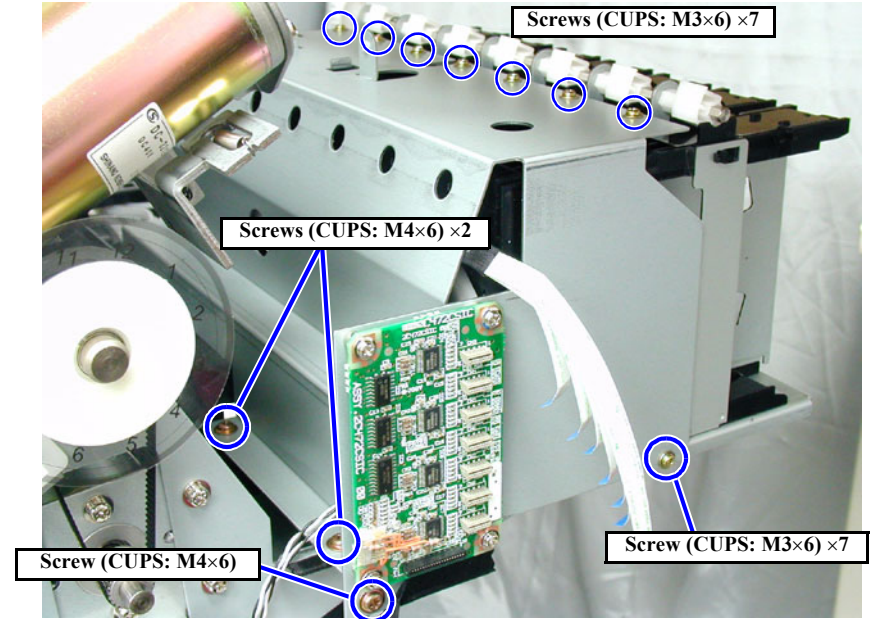

Figure 4-65. I/H Frame Removal 2/2

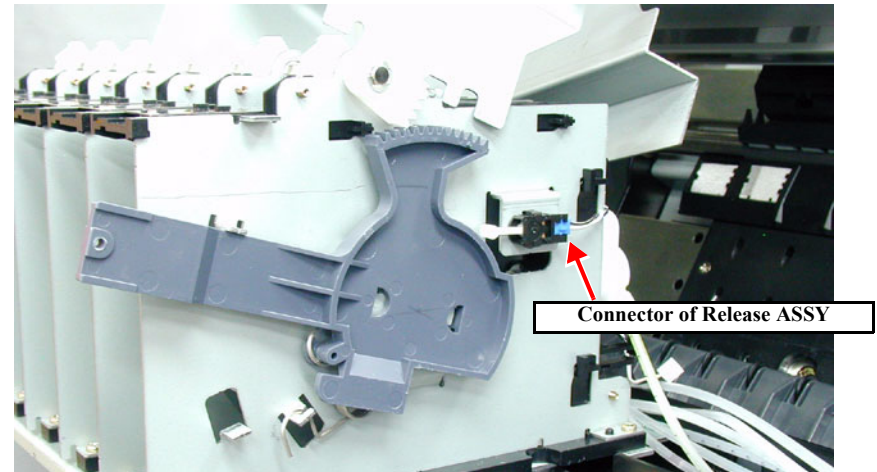

Figure 4-66. Release Sensor (I/H Lever) Removal

13. Disengage the two hooks on the back of the relevant Ink Holder ASSY and draw out the CSIC Relay Board. (See Figure 4-67)

REASSEMBLY

If you push in the CSIC Relay Board as a whole unit, the CSIC Contact Spring will be deformed. Be sure to install the CSIC Relay Board by the following procedure:

1. Disassemble the Holder ASSY to the units as shown below.
2. Remove the CSIC Contact Spring. (2 hooks)
3. Install the CSIC Relay Board.
4. Hold and inset the CSIC Contact Spring with care not to deform it with the edge of the Relay Board.

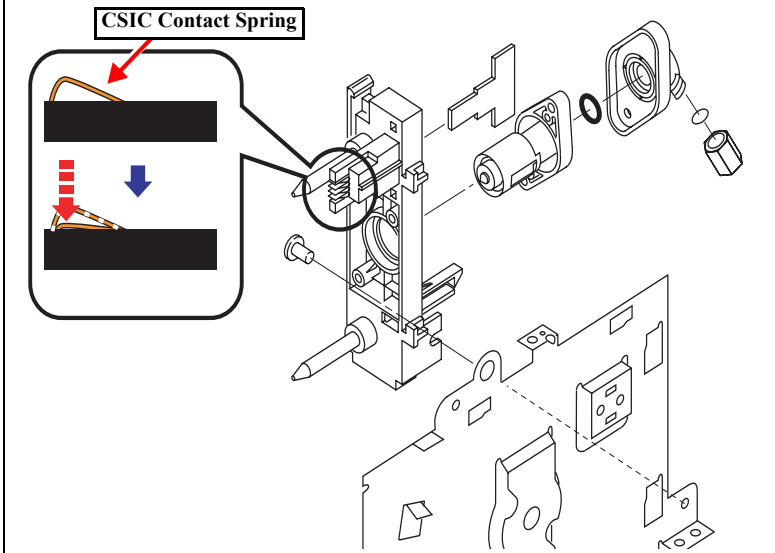

5. Remove the screw in the joint connecting the Ink Holder ASSY and the pipe (M6), then remove the O-ring from its inside.
6. Take out the two screws (CPS: M3×12) holding the Ink Holder ASSY to the I/H Base, then remove the Ink Holder ASSY. (See Figure 4-68)

REASSEMBLY

When installing the ink tube to the Ink Holder ASSY, first make certain that there is the O-ring. Then insert the ink tube into the innermost position properly and tighten the coupling screw.

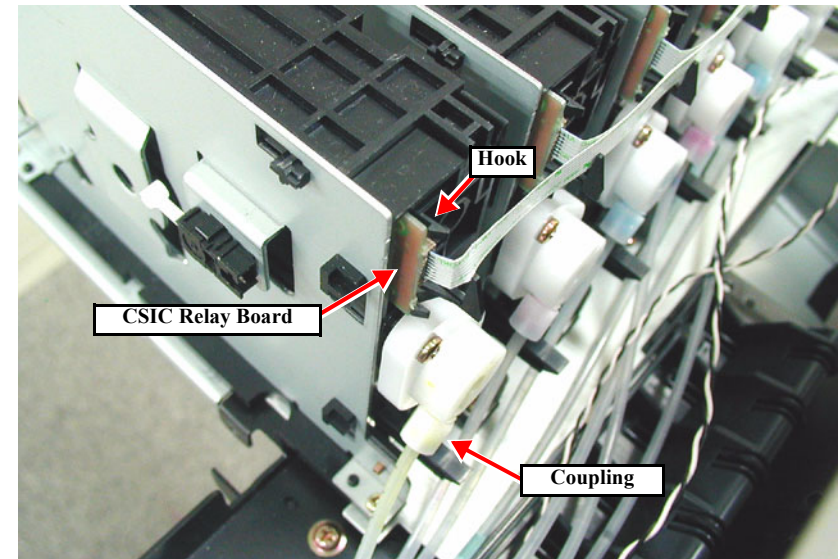

Figure 4-67. CSIC Relay Board Removal

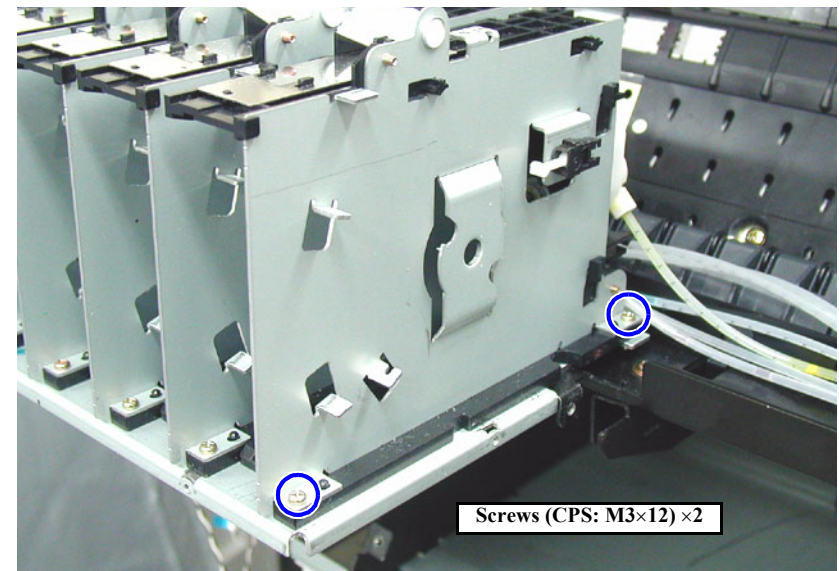

Figure 4-68. Ink Holder ASSY Removal

7. Take out the two screws (CUPS: M3×6) holding the Needle Frame ASSY.
(See Figure 4-69)
8. While disengaging the hook of the Needle Frame ASSY, slide the Ink Holder ASSY downward to separate the Needle Frame ASSY from the Ink Holder ASSY.
(See Figure 4-70)

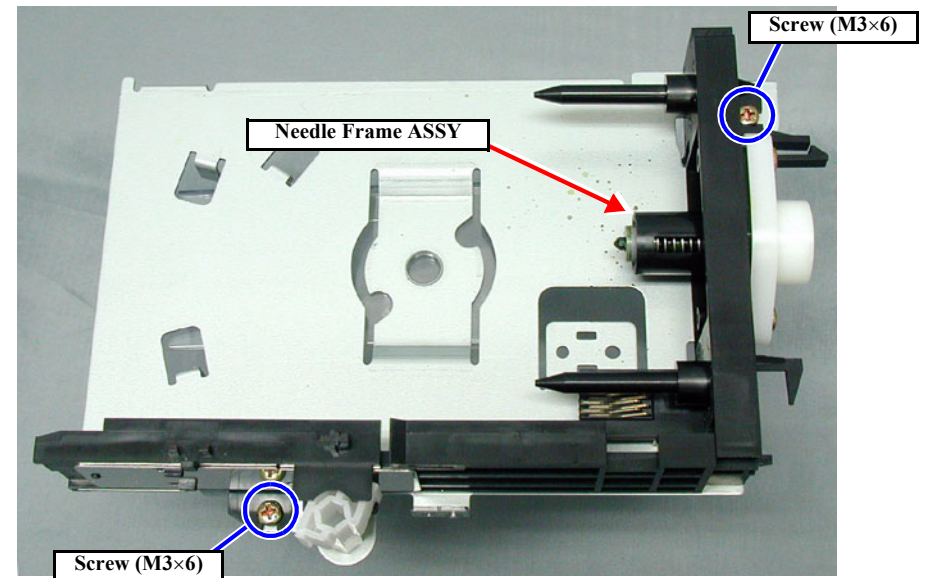

Figure 4-69. Disassembling the Ink Holder ASSY 1/2

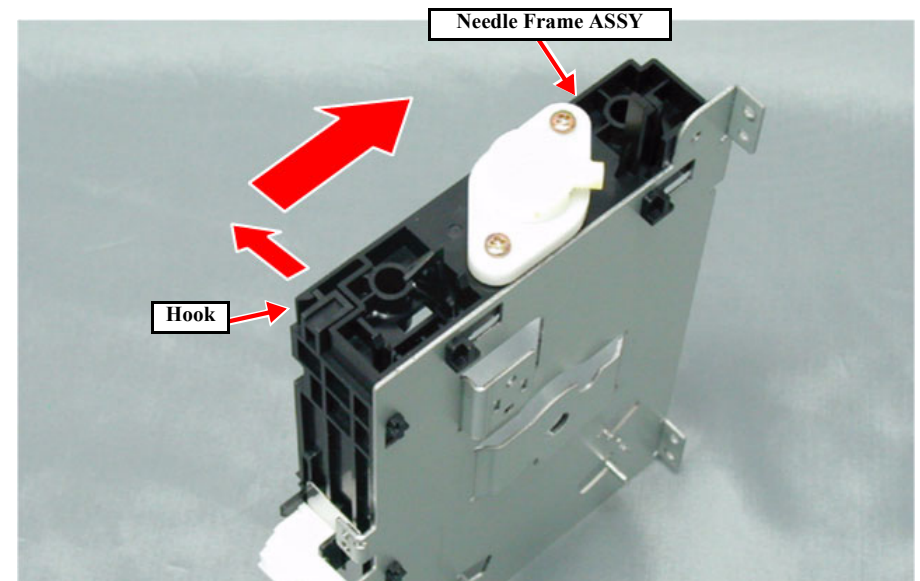

Figure 4-70. Disassembling the Ink Holder ASSY 2/2

4.5.3 Cover Sensor ASSY

1. Remove the *L Side Cover*. (p.163)
2. Remove the *I/H Cover*. (p.164)
3. Open the Front Cover.
4. Remove two screws (CPP: M3×8) securing the Ink Tube Cover and remove the cover. (See Figure 4-63)
5. Disconnect the harness connector of the Cover Sensor ASSY.
6. Pinch the right and left hooks of the Cover Sensor ASSY and remove the Cover Sensor ASSY.

ADJUSTMENT
REQUIRED



Make sure that the Cover Switch Holder is so positioned that the Cover Sensor ASSY operates coupled with the opening/closing of the Front Cover.

- Refer to “5.1.4.9 Cover Sensor ASSY Adjustment” (p.216)

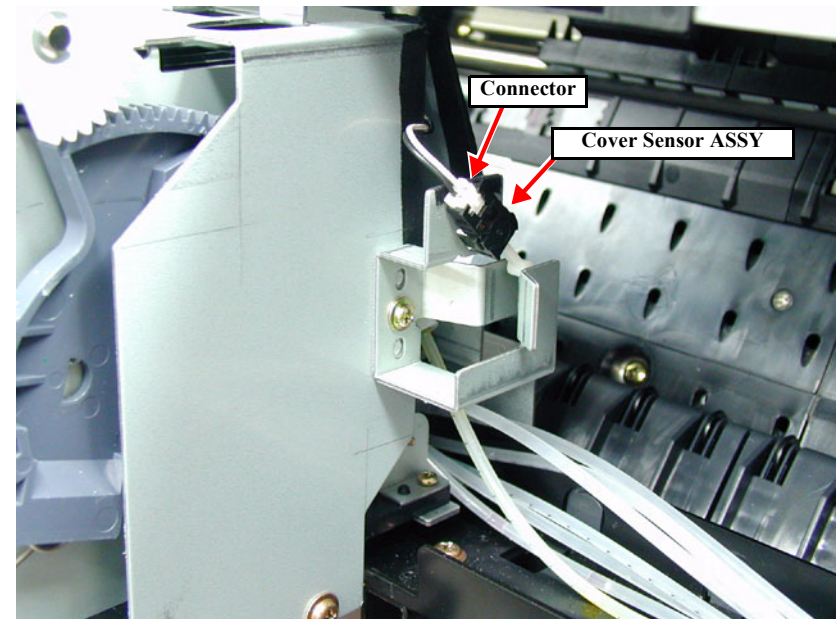

Figure 4-71. Removing the Cover Sensor ASSY

4.6 Disassembly and Assembly of Cleaning Mechanism

The Maintenance ASSY consists of the major assemblies listed below four of which constitute the Cleaning Unit.

The life of the Cleaning Unit is judged by the life of the Pump Motor. Replace the Cap ASSY, Pump ASSY, Flushing Box and Wiper at the same time.

Parts of the Cleaning Unit are available as individual parts so that each of those parts can be replaced singly.

NOTE: For details, refer to “Table 6-1 Stylus Pro 7600/9600 - Lives of Periodically Replaced Components and Maintenance (p.277)”.

Table 4-4. Major Parts of Cleaning Mechanism

Names of Parts		See
Pump Motor ASSY		p.200
Cleaning Unit * Replace at expiration of Pump Motor ASSY life	Pump/Cap ASSY	p.200
	Cap ASSY	p.201
	Pump ASSY	p.203
	Cleaner Head	p.204
Flushing Box ASSY		p.204



Once you have replaced the Cleaning Unit, be sure to execute CLEAR COUNTERS “Initialize cleaning unit (CLEANER) (p.71)” and CLEAR COUNTERS “Initialize flashing box (FL BOX) (p.71)” in Maintenance mode 2.

4.6.1 Maintenance ASSY Removal



When you replace the Maintenance ASSY, ink can spill from the ink tube connected to the pump assembly. Disconnect the ink tubes carefully so that ink will not spill.

1. Remove the R Side Cover. (p.160)
2. Remove the Access Cover. (See *Removing the Access Cover on page 167*)
3. Disconnect the connector (CN17) of the Pump Motor ASSY.
4. At the rear of the printer body, remove the four screws securing the Maintenance ASSY, and remove the Maintenance ASSY from the printer body. (See *Figure 4-72*)



After installing the Maintenance ASSY, insert the waste ink tube (thin) of the Pump Motor ASSY into the waste ink tube (thick) of the Flushing Box ASSY to the depth using tweezers.

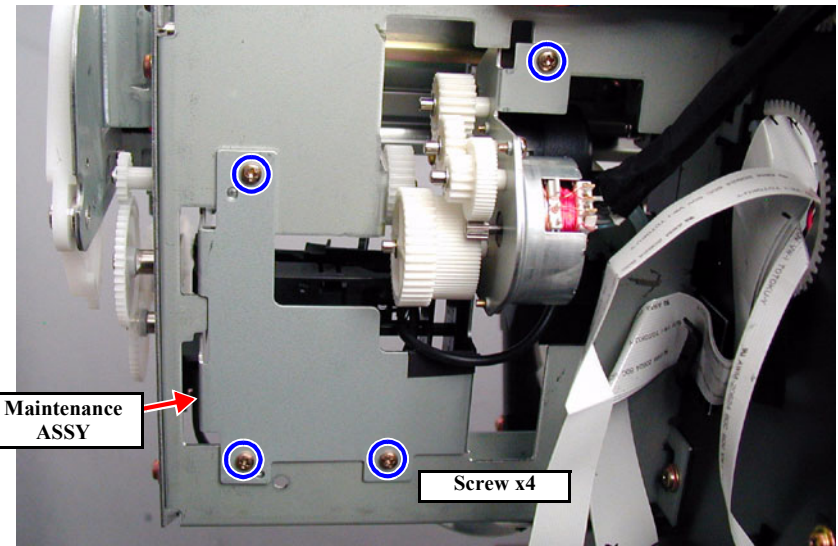
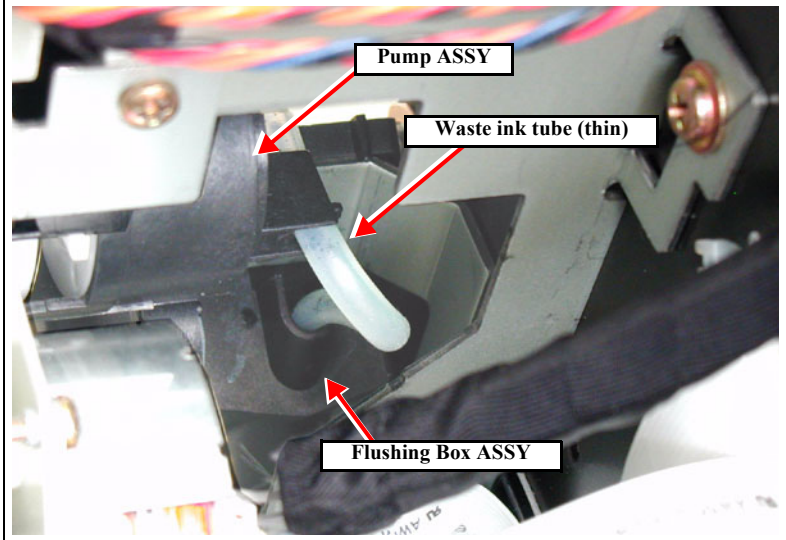

Figure 4-72. Removing the Maintenance ASSY

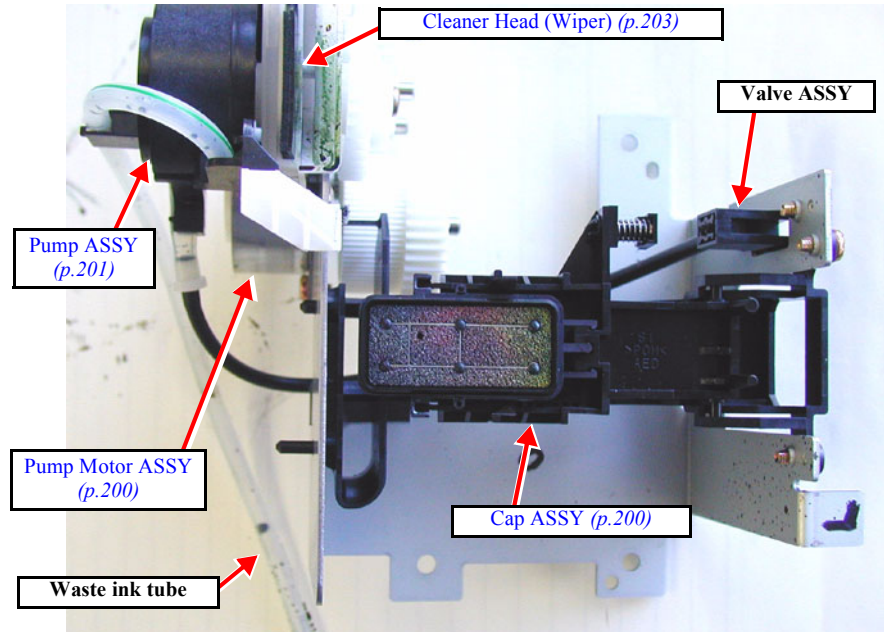

Figure 4-73. Maintenance ASSY

4.6.2 Pump Motor ASSY

1. Remove the Maintenance ASSY. (See p.199)
2. Remove the two (M3×8) screws securing the Pump Motor ASSY to the Maintenance ASSY and remove the Pump Motor ASSY.

4.6.3 Cap ASSY

1. Remove the Maintenance ASSY. (See p.199)
2. Disconnect the tube which connect the Valve ASSY to the Cap ASSY.
3. Remove the two screws securing the Cap ASSY and remove the Cap ASSY from the Maintenance ASSY.

CAUTION



Check for the points below when removing/mounting the Cap ASSY.

- Push the cap part down to the valve part and check that the cap part rebounds with spring force.
- Check that the valve part is not dislocated.

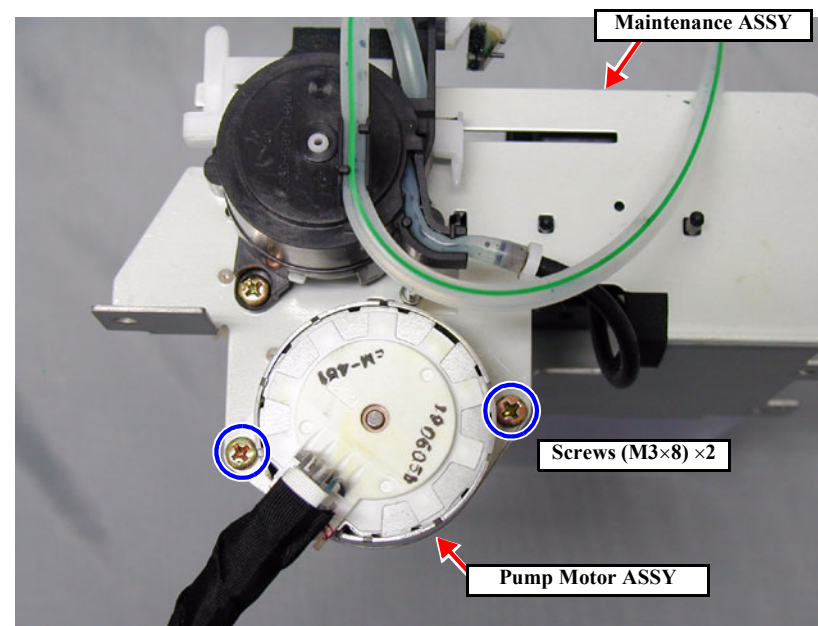

Figure 4-74. Removing the Pump Motor ASSY

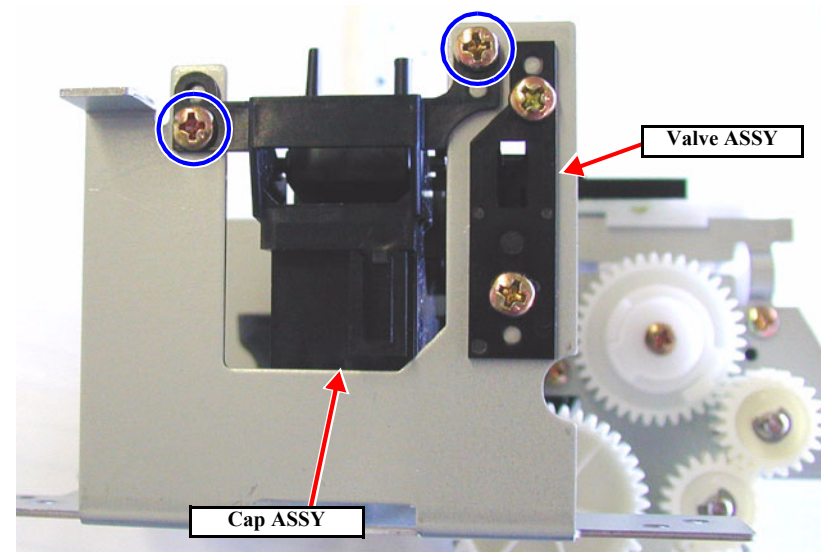

Figure 4-75. Removing the Cap ASSY

4.6.4 Pump ASSY

1. Remove the Maintenance ASSY. (See p.199)
2. Remove the one central screw (M3×4) of the Pump ASSY and remove the three parts including the gear. (See Figure 4-76)
3. Remove the two screws (M3×6) on the gear side.
4. Disconnect the tube from the Cap ASSY, remove the one screw (M 3×6) and remove the Pump ASSY.(See Figure 4-77)



Once you have replaced the Pump ASSY, execute “CLEAR COUNTERS” (See p.71).

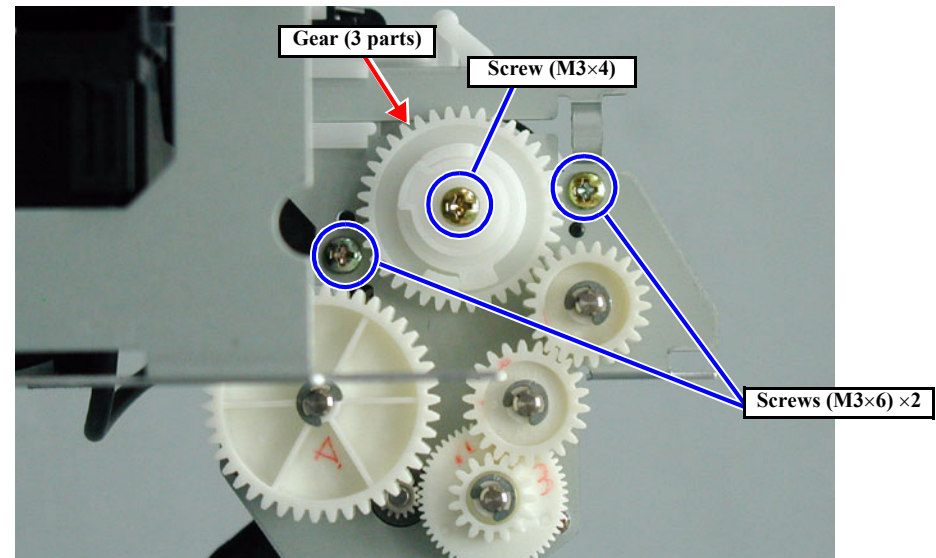

Figure 4-76. Removing the Pump ASSY 1/2

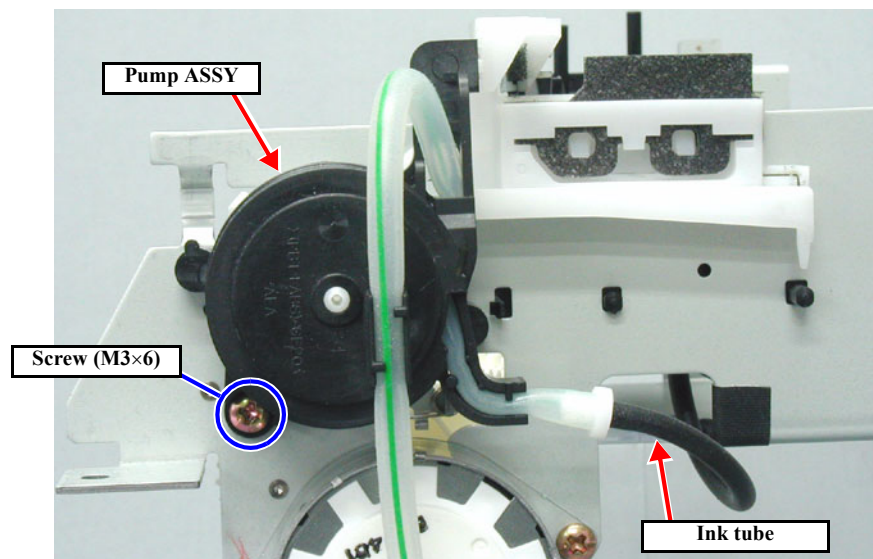
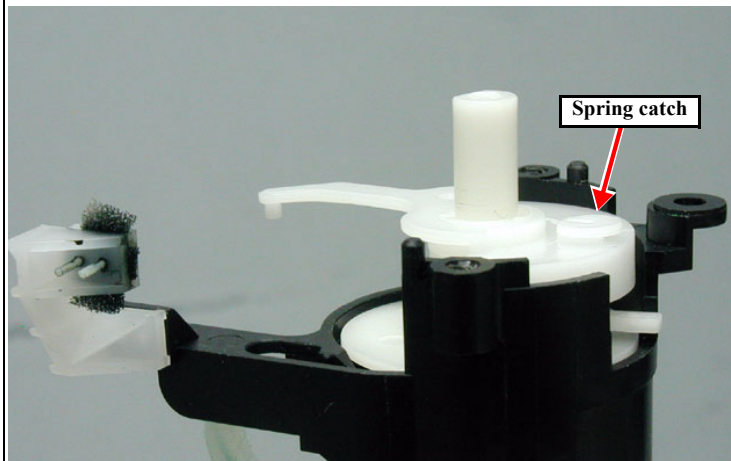

Figure 4-77. Removing the Pump ASSY 2/2

REASSEMBLY



- When installing the Pump ASSY, make sure that the spring is set in the spring catch.



- When installing the pump reduction gear, make sure that the gears are engaged properly.

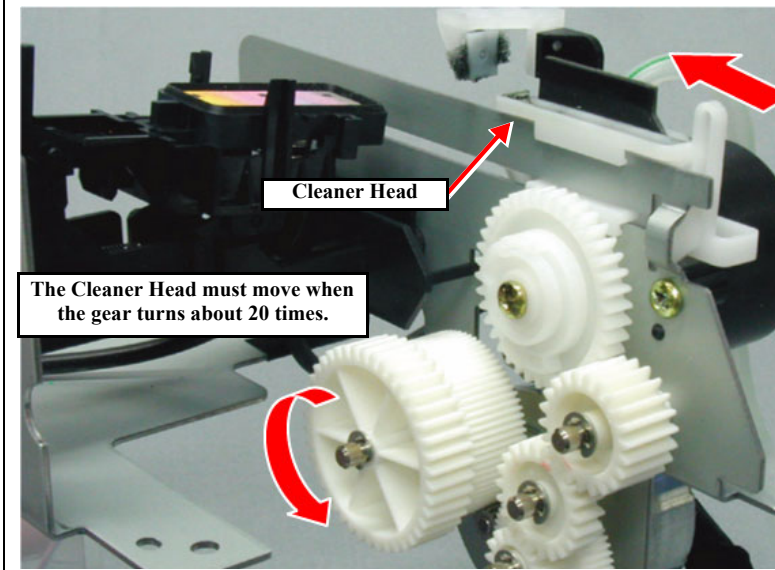

4.6.5 Cleaner Head (Wiper)

1. Remove the Maintenance ASSY. (See p.199)
2. Using tweezers, disengage the dent of the Cleaner Head from the projection on the Cleaner Head Holder and pull off the Cleaner Head.

CAUTION

- If you touch the Cleaner Head with a bare hand, the head nozzle can be stopped up with ink repelled by fat from your hand. For handling the Cleaner Head, be sure to use tweezers; never touch the Cleaner Head with your bare hand.
- Before use, clean the tweezers with cleaner.

REASSEMBLY

Install the Cleaner Head in such an orientation that its felt is positioned on the Pump ASSY side and the rubber in on the Cap ASSY side.

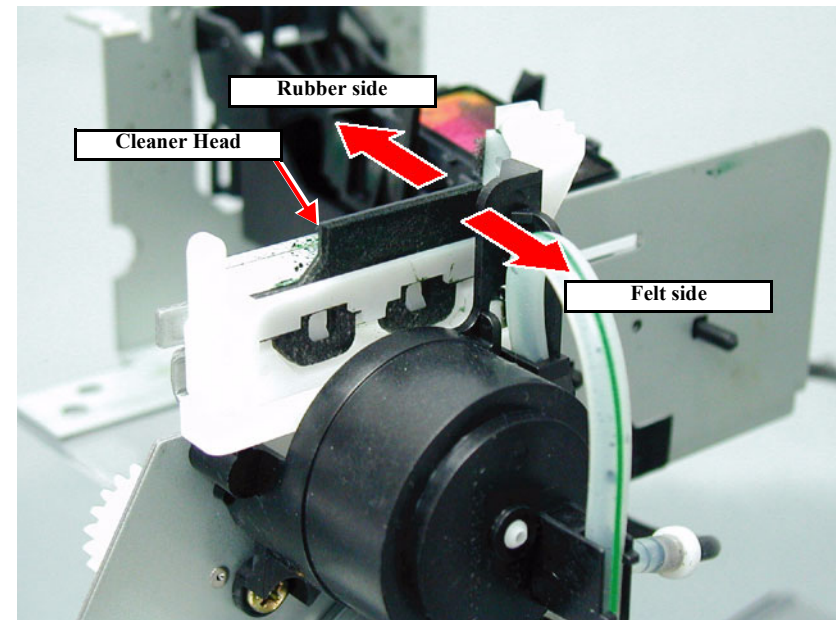

Figure 4-78. Removing the Cleaner Head

4.6.6 Flushing Box ASSY

1. Remove the *R Side Cover*. (p.160)
2. Remove the *Paper Guide L2*. (p.168)
3. From the printer body, pull off carefully the waste ink tube (thick) which connects the Flushing Box ASSY to the Maintenance Tank.
4. Remove the one (CUPS: M3×6) screw securing the Flushing Box ASSY.
5. Take out the Flushing Box, while pulling off carefully the waste ink tube (thin) coming from the Pump ASSY.
6. Remove the Flushing Box ASSY.



After installing the Flushing Box ASSY, make certain by removing the Paper Guide L2 that the waste ink tube (thick) is set securely on the tube joint of the Maintenance Cartridge Holder.

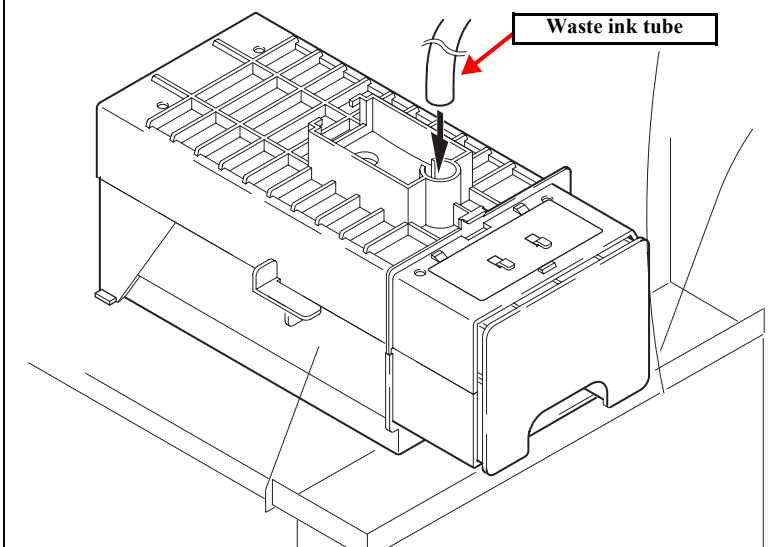

Take off the ink tube (thick/thin) carefully so that ink will not spill from the ink tube.

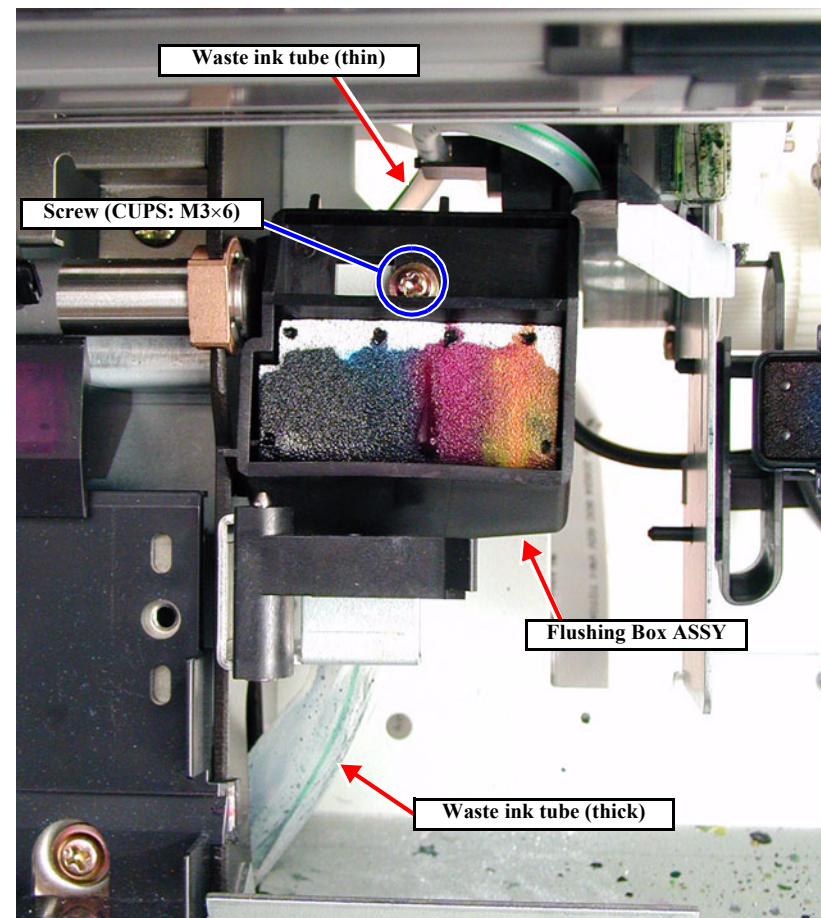

Figure 4-79. Removing the Flushing Box ASSY

4.7 Disassembly and Assembly of Circuit Boards

This section describes the procedures for removing the Power Supply Board, Main Board (C472MAIN) and AC Inlet.

4.7.1 Power Supply Board



Unplug the AC power cable and wait at least five minutes before removing the Power Supply Board to make sure there is no residual power left in the board's capacitors.

1. Remove the *Rear Cover*. (p.166)
2. Disconnect the following connectors from the Power Supply Board:

Table 4-5. Connectors on Power Supply Board

Connector No.	Pins	Color	Connection	Notes
CN001	3	White	AC inlet	Lock type
CN301	12	White	C472MAIN	Lock type

3. Remove the eight screws (CPS: M4×8) securing the Power Supply Board, and then remove the Power Supply Board.

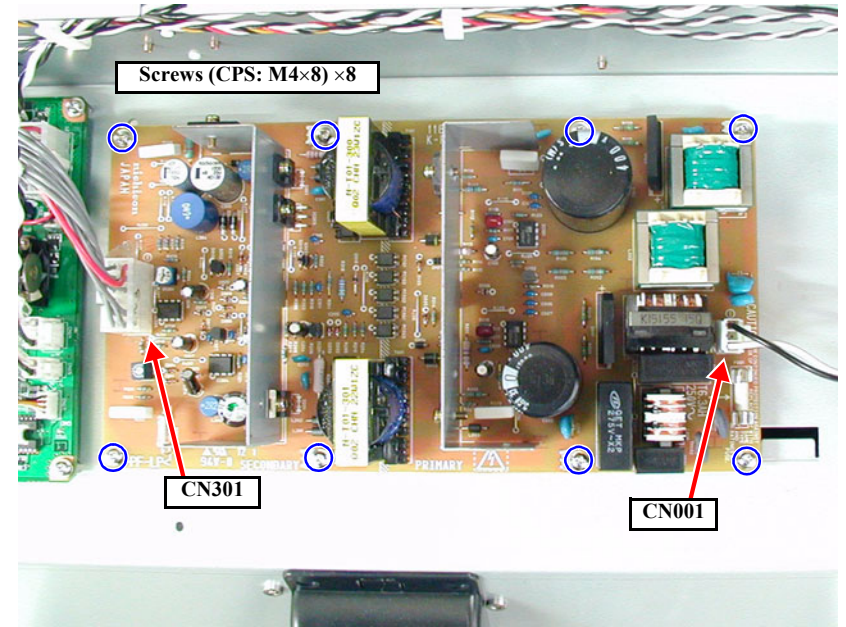

Figure 4-80. Power Supply Board Removal

4.7.2 AC Inlet



Unplug the AC power cable and wait at least five minutes before removing the Power supply Board to make sure there is no residual power left in the board's capacitors.

1. Remove the *Rear Cover*. (p.166)
2. Disconnect CN001 from the Power Supply Board. (See Figure 4-81)
3. Remove the one screw (M4×8) and toothed washer (M4) fastening the AC Inlet Ground Cable.
4. Push the hooks (one top and two bottom hooks) and remove the AC Inlet from the holder. (See Figure 4-82)



Install the AC Inlet in such an orientation that the ground cable side is positioned up.

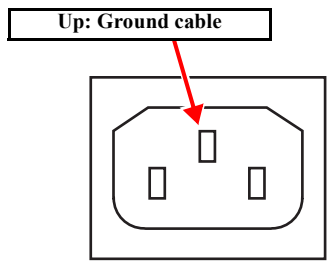

Board_AC10.eps

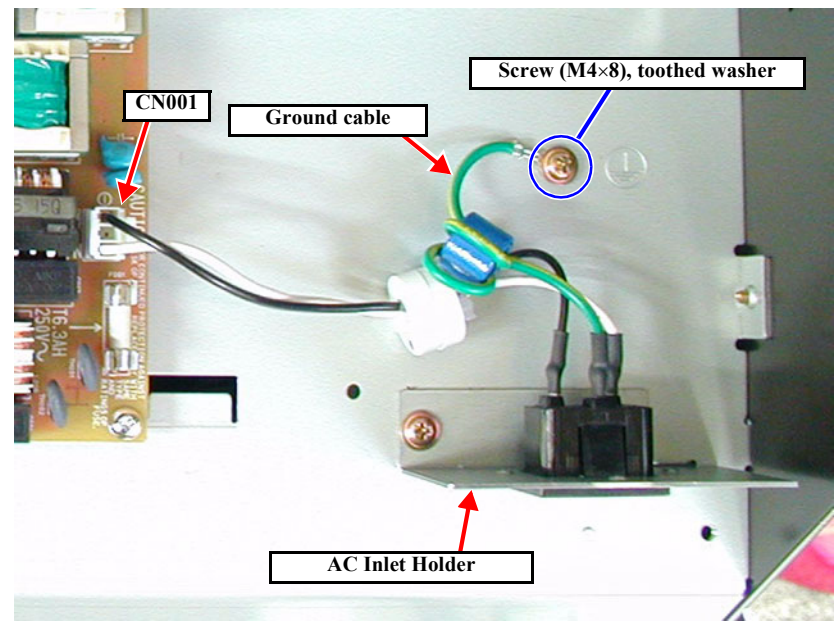

Figure 4-81. Removing the AC Inlet Holder

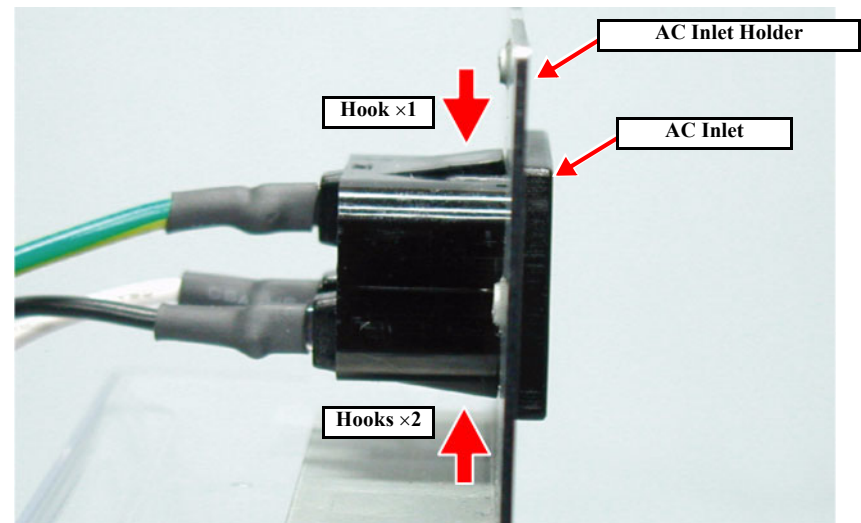

Figure 4-82. Removing the AC Inlet

4.7.3 MAIN Board (C472 MAIN)

CAUTION

When disconnecting or connecting the connector for an FFC cable on the Main Board, never pull or push the connector aslant. Disconnecting or connecting the connector can cause damage to, short circuit or breakage of the terminals inside the connector, thus resulting in damage to elements on the circuit board.

1. Remove the Rear Cover. (p.166)
2. Disconnect all the harness connectors from the Main Board.
3. Remove the two screws (CP(W): M3×6) securing the both ends of the parallel interface connector to the Main Board and seven other screws (CP(W): M3×6), and remove Main Board.

REASSEMBLY

Refer to the table on the next page for connections of connectors. The following connectors are not used:
CN4, CN7, CN12, CN18, CN25, CN28, CN33, CN36, CN37

**ADJUSTMENT
REQUIRED**

Before and after replacing the Main Board with a new one, make the following adjustment:
Refer to “5.1.4.2 Main Board Adjustment” (p.213)

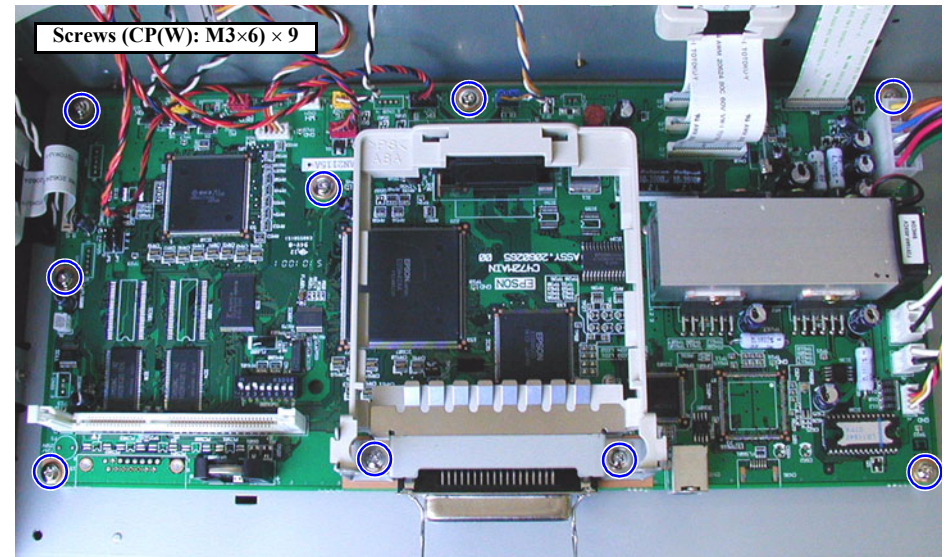

Figure 4-83. C472MAIN Board Removal

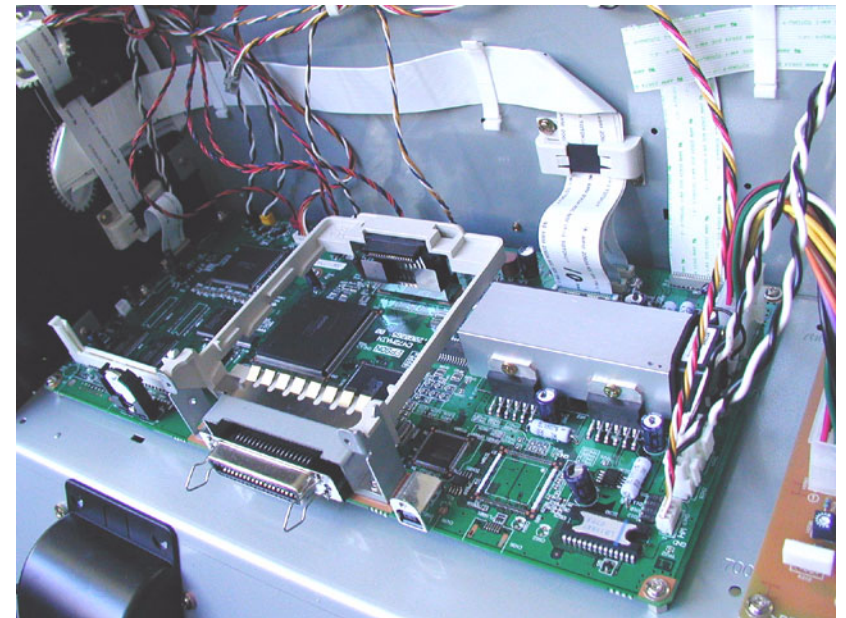
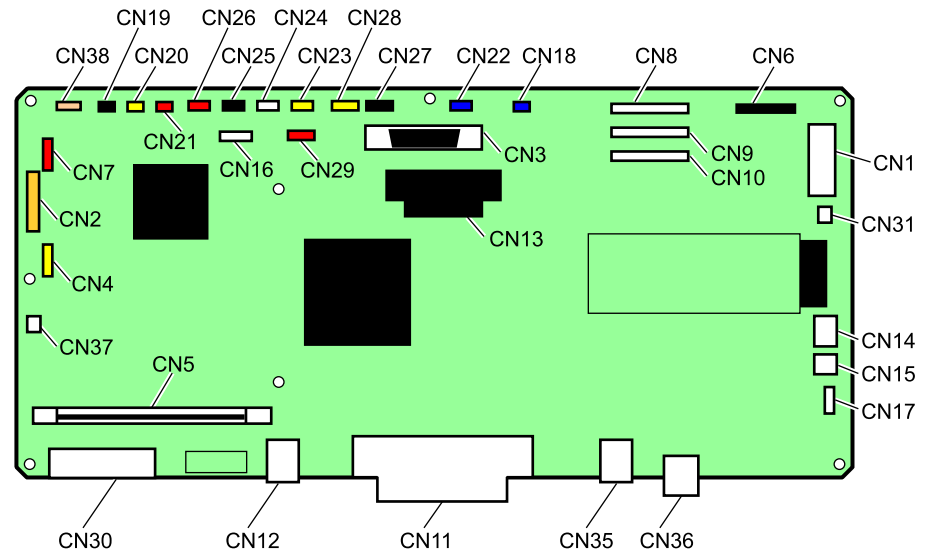

Figure 4-84. Harness Clamp Locations

□ Main Board Connector List

CN.No.	Pins	Color	Connection	Remarks
CN1	12	White	P/S board	Lock type
CN2	16		PANEL	FFC, lock type
CN3	36		H-UDI36	
CN4	5	Yellow	D/A_OUT	(Not used)
CN5	90		ROM_DIMM	
CN6	21		CSIC	FFC
CN7	5	Red	S_I/O(DEBUGER)	(Not used)
CN8	24		CR_FFC1	FFC, lock type
CN9	24		CR_FFC3	FFC, lock type
CN10	24		CR_FFC2	FFC, lock type
CN11	36		IEEE1284 (parallel port)	
CN12	4		USB	(Not used)
CN13	36		TYPE_B	
CN14	3	White	CR_MOT	Lock type, with relay connector
CN15	2	White	PF_MOT	Lock type, with relay connector
CN16	5	White	PF_ENC	
CN17	4	White	PUMP_MOT	With relay connector
CN18	2	Blue	P/S_FAN	
CN19	2	Black	FAN1	With relay connector
CN20	2	Yellow	FAN2	With relay connector
CN21	2	Red	FAN3	* Stylus Pro 9600 only
CN22	3	Blue	P_THICK0.3	
CN23	3	Yellow	COVER_L	
CN24	3	White	CR_ORG	
CN25	3	Black	I/H_LEVER	(Not used)
CN26	3	Red	P_THICK	
CN27	4	Black	P_REAR	
CN28	4	Yellow	P_FRONT	(Not used)
CN29	4	Red	HD_SLID	
CN30	15		ROLL_UNIT (option unit)	* Stylus Pro 9600 only
CN31	2	White	H_FAN	
CN33	3	White	RESET	
CN35	4		USB2.0	Right side (AC side)
CN36	8		IEEE1394	(Not used)
CN37	2		HDD_PS	(Not used)



Board_M10.eps

Figure 4-85. Connector Locations

4.7.4 DIP Switch and Jumper Setting at Factory before Shipment



Do not change the DIP Switches and Jumpers on the Main Board from their positions which were set at the factory before shipment. Changing their setting can result in malfunctions.

DIP Switches (SWD600)

Table 4-6. DIP Switch Setting at Factory at Shipment

SW	Setting at Factory	Function	Description
1	ON	Frequency Dispersion Setting (CPU/SDRAM characteristics)	SW1-2-3 ON-ON-ON : -0.5% ON-OFF-ON : -1.0% ON-ON-OFF : -2.5% ON-OFF-OFF : -3.75%
2	OFF		
3	ON		
4	OFF	Clock Frequency Setting	SW4-5 : CPU/SDRAM - USB ON-ON : 133.3MHz - 48MHz OFF-ON : 100MHz - 48MHz ON-OFF : 66.6MHz - 48MHz OFF-OFF: 50MHz - 48MHz
5	OFF		
6	OFF	Main board Revision Setting (MAINREV0)	
7	OFF	Main board Revision Setting (MAINREV1)	
8	OFF	Main board Revision Setting (MAINREV2)	

Jumpers (J5 / J6 / J7)

Table 4-7. Jumper Setting at Factory at Shipment

Jumper	Setting at Factory	Function D	Description
JP5	Open	Boot select	Open: Normal boot Short: Flash ROM
JP6	Short	DA1_Select	Open: Debug mode Short: Normal mode
JP7	Short	DA0_Select	Open: Debug mode Short: Normal mode

CHAPTER

5

ADJUSTMENT

5.1 Overview

This section describes the adjustment procedures necessary after replacing certain parts and explains how to perform those adjustment procedures.

5.1.1 Cautions

Before beginning the adjustment operation, be sure to confirm the following caution items.



- If you are carrying out adjustments, see “5.1.4 Adjustment Items” (p.212) and then confirm the relevant adjustment items and adjustment procedures.
- When carrying out adjustments, check the cautions displayed in the explanation for each adjustment item thoroughly. If the operation is performed wrong, it could hinder the product's operation or functions.

5.1.2 Adjustment Tools



In adjustments and test printing, use Doubleweight Matte Paper roll, unless otherwise specified.

Table below lists the tools necessary for adjustments of Stylus Pro 7600/9600.

Table 5-1. Adjustment Tools

Name	Part Code	Notes
Tension Gauge #F770	1060744 / standard tool acceptable	2.2kgf ± 220g (PF Belt tension)
Thickness gauge	Commercially available	Thickness: 0.3 / 0.4 / 0.8 / 0.9 mm
Coupling tightening jig		Tightening force: 3kgf + 500g

Table 5-1. Adjustment Tools (continued)

Name	Part Code	Notes
24/44-inch Width Roll Paper	Epson or commercially available paper (Doubleweight Matte Paper roll) <ul style="list-style-type: none"> • MCSP24R4 (24-inch width) • MCSP44R4 (44-inch width) 	For printer mechanism adjustments and test printing.
A3Tracing Paper #F751	1057723	Used for adjustment of the paper status detection sensor (P_REAR) level adjustment. Microtrace #300 LMB, made by Kimoto
A3 Copy Paper (PPC)	Commercially available product (Example: Fuji Xerox Bright Recycled)	Used for adjustment of the paper status detection sensor (P_EDGE) level adjustment.
Scale 1000mm #F713	1047746 / A commercially available scale can be purchased.	Length:1000mm
Scale Stopper #F714	1047745 / A commercially available scale can be purchased.	Used in combination with the #F713 (measurements in 0.1 mm units)
CR ENC sensor positioning jig #F799	1212926	
Cutter Positioning Jig #F800	1212928	
PF ENC sensor positioning tool #F798	1212925	
Ink Cartridge (x7)*		Spare
Draining cartridge*		Use at black ink type change
Maintenance Tank*		Spare

Note "*": Use at adjustments which require test printing.

5.1.3 Procedure for Adjustment Work

Follow the specified steps by consulting “5.2 Self-diagnostic Function” (p.220) and “5.3 Mechanism Adjustment” (p.263) for adjustment items of each unit/part.

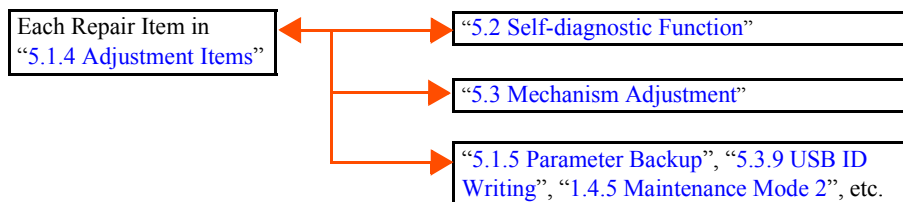

5.1.4 Adjustment Items

Table 5-2 below indicates the parts replacement repair items for Stylus Pro 7600/9600 which requires adjustments. For actually performed part replacements, and disassembly and reassembly operations, the specified adjustment items should be performed in the sequence shown in the instructions.

Table 5-2. Adjustment Items

Repair Item (Page for Disassembly and Assembly)		See for Adjustment
Print Head (p.171)		p.212
MAIN Board (C472 MAIN) (p.207)		p.213
CR Motor ASSY (p.180)		p.214
PF Motor (p.185)		p.214
Sensor	P_EGDE Sensor ASSY (p.179)	p.215
	P_REAR Sensor ASSY (p.191)	p.215
	P_THICK Sensor/P_THICK Sensor_0.3 ASSY (p.190)	p.215
	CR Encoder Sensor ASSY (p.178)	p.215
	Cover Sensor ASSY (p.197)	p.216
	PF Encoder Sensor ASSY (p.186)	p.216
Cutter Solenoid (p.177)		p.217
Paper Guide L2 (p.168)		
Damper ASSY (p.173)		p.217
Release Sensor (I/H Lever) (p.193)		p.217

5.1.4.1 Print Head Adjustment

Described below are the adjustment items to be made once the *Print Head* (p.171) has been replaced.



When replacing the print head with a new one, execute ink discharge (“Ink Blowing” on page 256) beforehand.

- Adjustment items (steps):

Table 5-3. Required Adjustment Items (Print Head)

Step	Adjustment Item	See
1	Clear the counter (Maintenance Mode2) (Power OFF → [Paper Source] + [Eject] + [Paper Feed] → Power ON) “HEAD”	p.70
	<Start the Self-diagnostic Function> (Power OFF → [Paper Feed Δ] + [Paper Feed ▽] + [Cut/Eject] → Power ON)	p.220
2	Head Rank Input (including initial filling)	p.233
3	Head Nozzle Checking (Cleaning)	p.237
4	Head Slant Checking	p.246
5	Round Trip Print Position Adjustment (Bi-D Adjustment)	p.248
6	Round Trip Print Position (Bi-D Adjustment) Checking	p.252
7	Head Gap Adjustment (Uni-D Adjustment)	p.253
8	Test Pattern Printing	p.255
9	Leak check pattern printing	p.259

5.1.4.2 Main Board Adjustment

Described below are the adjustment items to be made once the *MAIN Board (C472 MAIN)* (p.207) has been replaced.

- Adjusting tools:
 - A3 Tracing Paper #F751 (Microtrace #300 LMB)
 - A3 Copy Paper (PPC)
 - Scale 1000mm #F713
 - Scale Stopper #F714
- Work operations before adjustment:
 - [Parameter Backup](#) (p.218)
 - [Firmware Reinstallation](#) (p.219)
- Adjustment items (steps):



When “Parameter Backup” has been executed, make the adjustment by Procedure A in Table 5-4 below; there is no need of following Procedure B.

Table 5-4. Required Adjustment Items (Main Circuit)

Procedure A*1	Procedure B*2	Adjustment Item	See
		<Start the Self-diagnostic Function> (Power OFF → [Paper Feed Δ] + [Paper Feed ▽] + [Cut/Eject] → Power ON)	p. 220
1	1	Rear Sensor AD Adjustment	p. 231
2	2	Edge Sensor AD Adjustment	p. 232
	3	Initial Charge Flag Clear	p. 257
	4	Head Rank ID Checking	—
	5	Head Rank Input	p. 233
	6	Head Nozzle Checking (Cleaning)	p. 237
	7	Head Slant Checking	p. 246
	8	Feed Correction + T&B Adjustment	p. 239
	9	Rear Sensor Position Adjustment	p. 243
	10	Platen Position Adjustment (Flash Point Adjustment)	p. 244

Table 5-4. Required Adjustment Items (Main Circuit) (continued)

Procedure A*1	Procedure B*2	Adjustment Item	See
	11	Round Trip Print Position Adjustment (Bi-D Adjustment)	p. 248
	12	Round Trip Print Position (Bi-D Adjustment) Checking	p. 252
	13	Head Gap Adjustment (Uni-D Adjustment)	p. 253
	14	USB ID Input	p. 273
3	15	RTC writing initialization	p. 71
	16	Power Cleaning	p. 259
	17	Head Nozzle Checking (Cleaning)	p. 237
	18	Test Pattern Printing	p. 255

Note "1": Adjustment procedure when parameter backup has been executed
 "2": Adjustment procedure when parameter backup can not be executed

- Work operations after adjustment:
 - Replacing the maintenance tank and resetting the maintenance tank life counter
 1. Replace the maintenance tank with a new one.
 2. Start Maintenance Mode 2.
(Power OFF → [Paper Source] + [Eject] + [Paper Feed] → Power ON)
 3. Clear the counter.
(“CLEAR COUNTERS” → “MAINT. TANK”)

NOTE: For details, refer to “1.4.5 Maintenance Mode 2” (p.70).

5.1.4.3 CR Motor Adjustment

Described below are the adjustment items to be made once the *CR Motor ASSY (p.180)* has been replaced.

- Adjusting tools:
 - No special tools are required.
- Adjustment items (steps):

Table 5-5. Required Adjustment Items (CR Motor Replacement)

Step	Adjustment Item	See
1	Clear the counter (Maintenance Mode2) (Power OFF → [Paper Source] + [Eject] + [Paper Feed] → Power ON) “CR MOTOR” <Mechanism Adjustment>	p. 70
2	CR Timing Belt Tension Adjustment <Start the Self-diagnostic Function> (Power OFF → [Paper Feed Δ] + [Paper Feed ∇] + [Cut/Eject] → Power ON)	p. 263 p. 220
3	Round Trip Print Position Adjustment (Bi-D Adjustment)	p. 248
4	Round Trip Print Position (Bi-D Adjustment) Checking	p. 252
5	Head Gap Adjustment (Uni-D Adjustment)	p. 253
6	Test Pattern Printing	p. 255

5.1.4.4 PF Motor Adjustment

Described below are the adjustment items to be made once the *PF Motor (p.185)* has been replaced.

- Adjusting tools:
 - Tension gauge (for 4,000g)
 - PF ENC sensor positioning tool #F798
 - Scale 1000mm #F713
 - Scale Stopper #F714
- Adjustment items (steps):

Table 5-6. Required Adjustment Items (PF Motor Replacement)

Step	Adjustment Item	See
	<Mechanism Adjustment>	
1	PF Timing Belt Tension Adjustment	p. 264
2	PF ENC Installation Position Adjustment <Start the Self-diagnostic Function> (Power OFF → [Paper Feed Δ] + [Paper Feed ∇] + [Cut/Eject] → Power ON)	p. 272 p. 220
3	Feed Correction + T&B Adjustment	p. 239
4	Test Pattern Printing	p. 255

5.1.4.5 P_EDGE Sensor ASSY Adjustment

Described below are the adjustment items to be made once the *P_EDGE Sensor ASSY (p.179)* has been replaced.

- Adjusting tools:
 - A3Tracing Paper #F751(Microtrace #300 LMB)
 - A3 copying paper (PPC)
 - Scale 1000mm #F713
 - Scale Stopper #F714
- Adjustment items (steps):

Table 5-7. Required Adjustment Items

Step	Adjustment Item	See
	<Start the Self-diagnostic Function> (Power OFF → [Paper Feed Δ]+[Paper Feed ∇]+[Cut/Eject] → Power ON)	p. 220
1	P_Edge Sensor AD Adjustment	p. 232
2	Feed Correction + T&B Adjustment	p. 239

5.1.4.6 P_REAR Sensor ASSY Adjustment

Described below are the adjustment items to be made once the *P_REAR Sensor ASSY (p.191)* has been replaced.

- Adjusting tools:
 - A3Tracing Paper #F751(Microtrace #300 LMB)
- Adjustment items (steps):

Table 5-8. Required Adjustment Items

Step	Adjustment Item	See
	<Start the Self-diagnostic Function> (Power OFF → [Paper Feed Δ]+[Paper Feed ∇]+[Cut/Eject] → Power ON)	p. 220
1	P_Rear Sensor AD Adjustment	p. 231
2	Rear Sensor Position Adjustment	p. 243

5.1.4.7 P_THICK/P_THICK_0.3 Sensor ASSY Adjustment

Described below are the adjustment items to be made once the *P_THICK Sensor/P_THICK Sensor_0.3 ASSY (p.190)* has been replaced.

- Adjusting tools:
 - Thickness gauge (0.3/ 0.4, 0.8/ 0.9mm)
- Adjustment items (steps):

Table 5-9. Required Adjustment Items

Step	Adjustment Item	See
	<Start the Self-diagnostic Function> (Power OFF → [Paper Feed Δ]+[Paper Feed ∇]+[Cut/Eject] → Power ON)	p. 220
1	Testing will be executed by “Sensor” (Test menu) → “Paper”	p. 224

5.1.4.8 CR Encoder Sensor ASSY Adjustment

Described below are the adjustment items to be made once the *CR Encoder Sensor ASSY (p.178)* has been replaced.

- Adjusting tools:
 - CR ENC sensor positioning jig #F799
- Adjustment items (steps):

Table 5-10. Required Adjustment Items

Step	Adjustment Item	See
	<Mechanism Adjustment>	
1	CR Encoder Sensor Mounting Position Adjustment	p. 268

5.1.4.9 Cover Sensor ASSY Adjustment

Described below are the adjustment items to be made once the *Cover Sensor ASSY (p.197)* has been replaced.

- Adjustment items (steps):

Table 5-11. Required Adjustment Items

Step	Adjustment Item	See
	<Mechanism Adjustment>	
1	Sensor position adjustment *	p. 267
	<Start the Self-diagnostic Function> (Power OFF → [Paper Feed Δ]+[Paper Feed ∇]+[Cut/Eject] → Power ON)	p. 220
2	Testing will be executed by "Sensor" (Test menu) → "Cover"	p. 224

Note "*": The gap is acceptable, if it does not permit entrance of your finger when the Front Cover is opened and "COVER OPEN" is displayed.

5.1.4.10 PF Encoder Sensor ASSY Adjustment

Described below are the adjustment items to be made once the *PF Encoder Sensor ASSY (p.186)* has been replaced.

- Adjusting tools:
 - PF ENC sensor positioning tool #F764
 - Cutter Positioning Jig #F800
 - Scale 1000mm #F713
 - Scale Stopper #F714
- Adjustment items (steps):

Table 5-12. Required Adjustment Items

Step	Adjustment Item	See
	<Mechanism Adjustment>	
1	PF ENC Installation Position Adjustment	p. 272
	<Start the Self-diagnostic Function> (Power OFF → [Paper Feed Δ]+[Paper Feed ∇]+[Cut/Eject] → Power ON)	p. 220
2	Feed Correction + T&B Adjustment	p. 239
3	Rear Sensor Position Adjustment	p. 243

5.1.4.11 Cutter Solenoid ASSY or Paper Guide L Adjustment

Described below are the adjustment items to be made once the *Cutter Solenoid (p.177)* has been replaced or the Paper Guide L has been reinstalled.

- Adjusting tools:
 - Cutter Positioning Jig #F800
 - Scale 1000mm #F713
 - Scale Stopper #F714
- Adjustment items (steps):

Table 5-13. Required Adjustment Items

Step	Adjustment Item	See
	<Mechanism Adjustment>	
1	Cutter Positioning Adjustment	p. 269
2	Checking for Proper Cutting and Cutter Position	p. 271
	<Start the Self-diagnostic Function> (Power OFF → [Paper Feed Δ]+[Paper Feed ∇]+[Cut/Eject] → Power ON)	p. 220
3	Checking for Proper Cutting Pressure	
4	Feed Correction + T&B Adjustment	p. 239

5.1.4.12 Damper ASSY Adjustment

Described below are the adjustment items to be made once the *Damper ASSY (p.173)* has been replaced.



- Execute ink discharge (“*Ink Blowing*”) before removing the Damper ASSY.
Refer to “*5.2.3.20 Clean Head (p.256)*”.
- Secure the coupling screw and the ink tube by tightening at the specified torque. (2 ~ 2.5 kg/f)

- Adjustment items (steps):

Table 5-14. Required Adjustment Items (Damper ASSY)

Step	Adjustment Item	See
	<Start the Self-diagnostic Function> (Power OFF → [Paper Feed Δ]+[Paper Feed ∇]+[Cut/Eject] → Power ON)	p. 220
1	Including initial filling	p. 259
2	Head Nozzle Checking (Cleaning)	p. 237
3	Leak check pattern printing	p. 259
4	Test Pattern Printing	p. 255

5.1.4.13 Release Sensor (I/H Lever) Adjustment

No adjustment is required

5.1.4.14 Battery

No adjustment is required. Execute “*Initialize RTC (p.83)*”.

5.1.5 Parameter Backup

5.1.5.1 Parameter Backup Procedure

- Required tools:
 - Flash ROM-DIMM: C309PROG Board (Part code: 2076654-01)
 - Parameter backup utility: PBU16.RCC
 - PC and parallel cable
 - EPSON page printer: AcuLaser C8600

5.1.5.2 Work Procedure

PREPARATION

1. Prepare the EPSON page printer as specified above. (AcuLaser C8600)
2. Install the flash ROM-DIMM in the optional ROM-DIMM slot (slot "A") on the Main Board of the page printer.
3. Connect the parallel cable from the PC to the parallel port of the page printer.
4. Turn on the power to the page printer while holding down the following buttons on the control panel of the page printer:
[Job Cancel] + [Up] + [Down]
5. When the LCD on the control panel of the page printer changes as "ROM A Erasing" → "ROM A Format error", send the parameter backup utility file (PBU16.RCC) from the PC.
6. Transfer of the utility file is completed when the LCD on the control panel of the page printer changes as "ROM A Writing" → "ROM A Format error". Then the ROM-DIMM can be used for parameter backup work.

EXECUTION OF PARAMETER BACKUP

1. Remove the Access Cover at the rear of Stylus Pro 7600/9600 and set the prepared ROM-DIMM in the ROM-DIMM slot on the Main Board.
2. Turn on the power to the Stylus Pro 7600/9600, and the LCD on the control panel will display "Write:F->M Push:M->F".
3. Upon passage of 5 seconds without pressing any button on the control panel, parameter backup will automatically be executed. (The contents of NVRAM ("F") on the Main Board will be copied onto ROM-DIMM ("M").)
4. Backup is completed when the LCD on the control panel changes as "Flash->ROM-DIMM" → "End [Success]".
5. Turn off the power to Stylus Pro 7600/9600 and take the ROM-DIMM out of the slot on the Main Board.

5.1.5.3 Others

If you would like to prepare two or more ROM-DIMMs of the same contents as those of the ROM-DIMM prepared at "PREPARATION" above, follow the following procedure for efficient work:

1. Prepare the EPSON page printer AcuLaser C8600.
2. Install the flash ROM-DIMMs in the optional ROM-DIMM slots on the Main Board of the page printer as follows:
Slot "A" = Blank flash ROM-DIMM (for writing)
Slot "B" = Master ROM-DIMM (the one on which the parameter backup file was written at "PREPARATION")
3. Turn on the power to the page printer while holding down the following buttons on the control panel of the page printer:
[Start/Stop] + [Job Cancel] + [Enter]
4. When the LCD on the control panel has displayed "ROM Copy Mode", press the [Enter] button on the panel.
5. Copy processing is executed and completed when the display has changed as "ROM A Erasing" → "ROM B>A Copying" → "ROM B>A Copying End".
6. Turn off the power to the page printer and take the ROM-DIMMs out of the slots.

5.1.6 Firmware Reinstallation

In Stylus Pro 7600/9600, the firmware is written in the Flash ROM on the Main Board. When the Main Board has been replaced with a new one, write the firmware in the Flash ROM on the new Main Board by the procedure described below.

CAUTION



- Immediately after reloading firmware to the new MAIN board without any parameters existing on it, when the printer's power is turned on, the ink initial refilling operation starts. If initial refilling is not necessary, be sure to start the printer by the following procedure.
 1. Start the Self-diagnostic function when the power is turned On.
 2. Select "Parameter: Update" under "Check: Parameter".
 3. Select "Update: InkParameter".
 4. Select "Reset" in "Init. Fill".
 5. Turn the printer's power switch Off, then turn it On again.
- The correct firmware data file should be used to match the download method.

5.1.6.1 Firmware Installation through ROM-DIMM

Install the firmware through a ROM-DIMM by the following procedure:

1. Check the firmware version.
([SelecType] key → "PRINTER STATUS MENU" → "VIRSION")
2. Write the firmware file in the RCC format in a ROM-DIMM (C309 PROG).
3. Turn off the power switch and disconnect the power cable from the printer body.
4. Remove the cover at the rear of the printer body and insert the ROM-DIMM prepared at step 1 into the dedicated socket.
5. Turn on the power to the printer body.
6. The firmware will be installed automatically and installation will be completed.
7. Turn off the power switch and disconnect the power cable from the printer body.
8. Pull the ROM-DIMM out of the dedicated socket.
9. Turn on the power to the printer body and check the firmware version.

5.1.6.2 Firmware Installation through Interface

This section describes the procedure for firmware installation through the parallel interface, as an example.

CHECK POINT



Set the parallel interface in the compatibility mode.

1. Connect the host PC to the printer with the parallel cable.
2. Turn on the power to the printer body.
3. Check the firmware version.
([SelecType] key → "PRINTER STATUS MENU" → "VIRSION")
4. Make certain that the panel display of the printer body shows "READY".
5. Transmit the firmware file in the IPL format from the host PC to the printer.
6. Firmware installation is completed.
7. Turn off the power to the printer once and then turn it on again.

5.2 Self-diagnostic Function



- With this function, all the processing except for some items are executed on the assumption that roll paper is used. Take care, since even sheets, if loaded, are handled as roll paper.
- During execution of this function, detection of remaining volume in ink cartridges and Maintenance Tank is not performed. Therefore, when you execute this function for print head replacement or any other work which requires consumption or discharge of a large volume of ink, check the remaining volume in ink cartridges and Maintenance Tank beforehand. (If you neglect this checking, the capacity of the Maintenance Tank can be exceeded so that ink may flow out; never forget to perform this checking.)

5.2.1 Overview

Self-diagnosis is chiefly intended to determine the parameters for mechanism adjustment and firm adjustment.

This function is incorporated in the printer firmware. It is enabled when the power to the printer is turned on while pressing the specific panel keys.

NOTE: The printer can not be shifted from the normal mode to the self-diagnostic mode.

5.2.1.1 How to Start Self-diagnostic Function

The key operation to start the self-diagnostic function is as follows:

1. Power is off.
2. Press “Paper Feed Δ” + “Paper Feed ∇” + “Cut / Eject”.
3. Turn the power on.
4. The self-diagnostic menu is displayed.
5. Turn the power off to close the self-diagnostic function.

5.2.1.2 Functions of Keys during Self-diagnosis

Described below are the functions of panel keys in the self-diagnostic mode:

Table 5-15. Key Functions in Self-diagnostic Mode

Normal Mode	Self-diagnostic Mode	Functions
Pause	Previous Level	Returns the setting item to the previous level of the menu hierarchy.
SelecType	Setting Item (Next)	Lowens the level in the menu hierarchy by one.
Paper Source (Items)	Setting Item (Previous)	Enhances the level in the menu hierarchy by one.
Paper Feed Δ	Setting Value +	Changes the menu in the upward direction. Setting value +
Paper Feed ∇	Setting Value –	Changes the menu in the downward direction. Setting value –
Cut / Eject (Enter)	Enter	Sets the setting value.
Cleaning	Paper Feed & Cut	<input type="checkbox"/> If it is pressed, the paper is fed, and when it is released, the paper is cut. <input type="checkbox"/> Moves the cursor. (only for specific items)

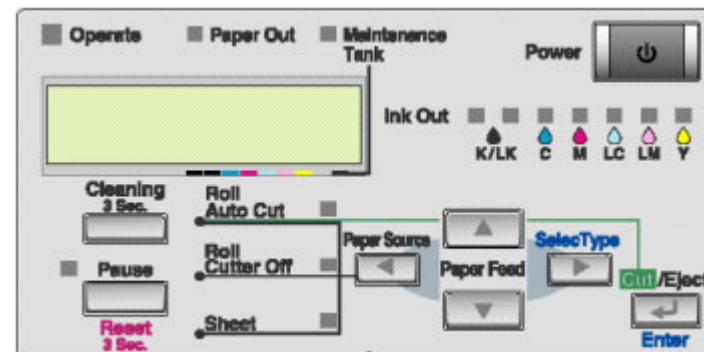

Figure 5-1. Panel Function in Self-diagnostic Mode

5.2.1.3 Top Menu

The following diagnostic items are available in the self-diagnostic mode. This section describes the diagnostic items available and transition in the top menu.

Table 5-16. Self-diagnostic Function List

Item	Description
Test	Version, Control Panel, Sensor, Encoder, Fan, Record, CSIC, Actuator, Actuator 2
Adjustment	Head system adjustment, sensor position adjustment, paper feed compensation, cutter adjustment
Cleaning	Cleaning with mode specified
Print	Test pattern printing, adjustment variables printing
Parameter*	NVRAM initialization, updating, display
Life *	Carriage motor, paper feed motor, CR+PF motor, cutter, head up and down, head lock, cleaning, printing, comprehensive endurance, CR+PF+discharging, comprehensive endurance 2, comprehensive endurance 3, checking

Note "*": This diagnostic item is not explained, since it is used only by testing at the factory, not executed on the service site.

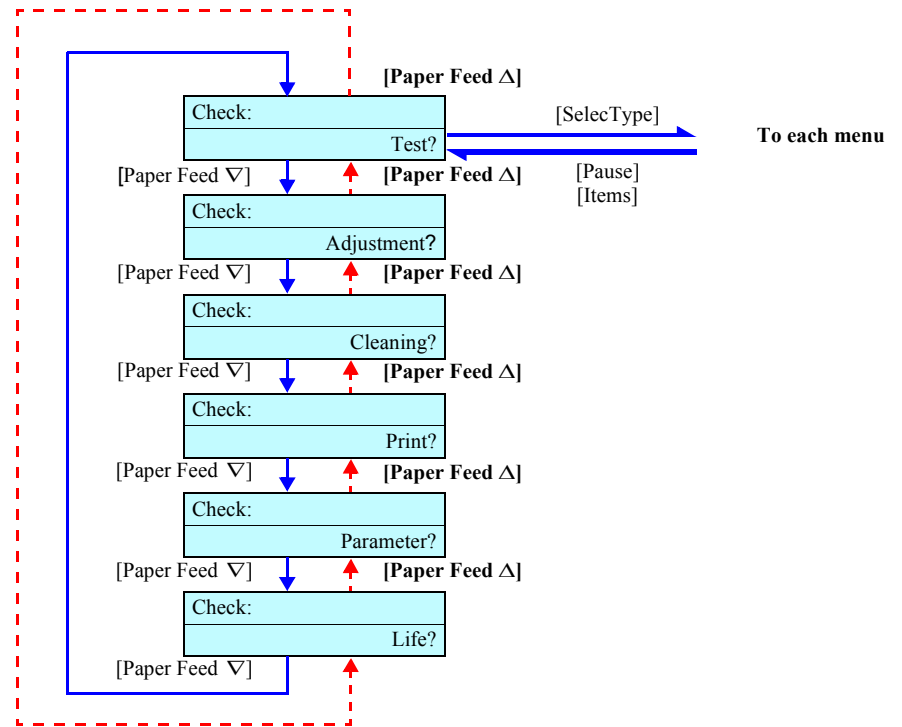

Figure 5-2. Top Menu Transition

5.2.2 Test

“Test” is intended to check the circuit boards.

Table 5-17. Circuit Board Check Items

Item	Description	See
Version	Program, Backup parameters, DIP switch, Panel review	p. 223
Control Panel	Keys, LCD, LEDs	p. 223
Sensors	CR origin, Covers, Paper thickness, Levers, Cartridge presence, Ink lever, Edge AD, Rear AD, Head thermistor, Driver thermistor, Take-up Reel Unit, Maintenance tank	p. 224
Encoder	CR_ENC (carriage), PF_ENC (paper feed)	p. 225
Fan	Paper suction fan (all operation), Paper suction fan (individual operations), Head driver heat sink cooling fan	p. 225
Record	Maintenance, Major faults	p. 226
CSIC	CSIC information display	p. 227
Actuator	Cutter	p. 229
Actuator 2	Cutter solenoid, Pump motor	p. 229

Note " * ": This diagnostic item is not explained, since it is used only by testing at the factory, not executed on the service site.

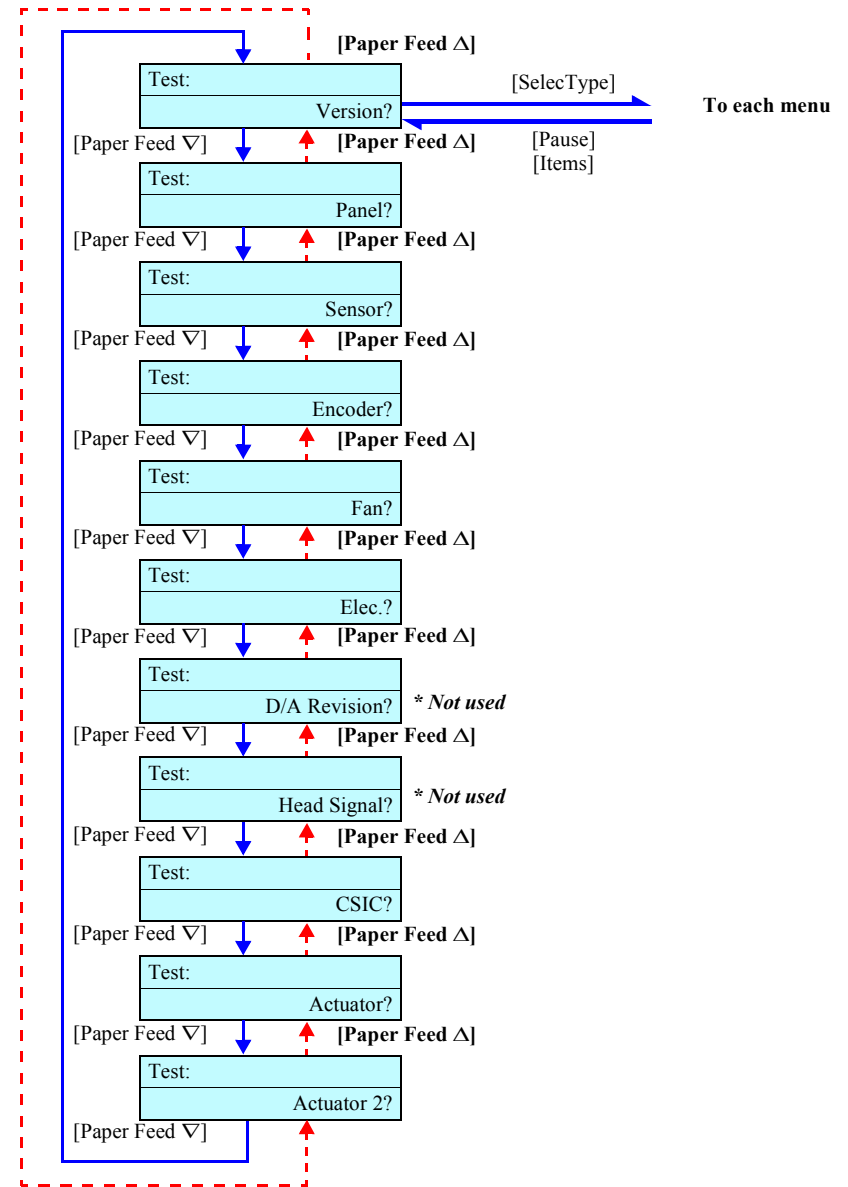

Figure 5-3. Inspection Menu Transition

5.2.2.1 Version

Check the firmware version and the DIP switch (ON: 0, OFF: 1).
 When this item is selected, the contents is shown on the panel one by one.
 (See Figure 5-4)

Firmware version display is as follows:

B W d d y m
 B N d d y m

■ Description

- BW: Stylus Pro 9600
- BN: Stylus Pro 7600
- dd: 2-digit decimal number representing the day of release
- y: Decimal number representing the units digit of the year of release
- m: 1-digit hexadecimal number representing the month of release

■ Example

The firmware version released on July 5, 2000 is:

- BW0507 (Stylus Pro 9600)
- BN0507 (Stylus Pro 7600)

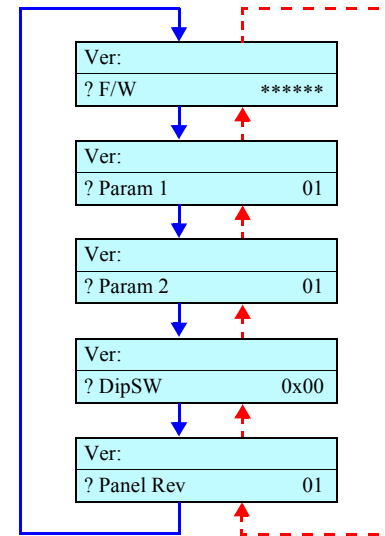

Figure 5-4. Menu Transition of Version Display

5.2.2.2 Control Panel

Check the keys, LCD and LEDs on the control panel. (See Figure 5-5)

- In the panel key check, the panel displays the name of a pushed key.
- Press the Pause key two times to complete the panel key check.
- In the LED check, the Operate, Pause, Ink Out K, LK, C, M, LC, LM, Y, Paper Out, Auto Cut, Cutter OFF, Sheet, and Maintenance Tank LEDs are lighted up in the order named.
 At the same time, the LCD shows the name of the LED which is currently lit.

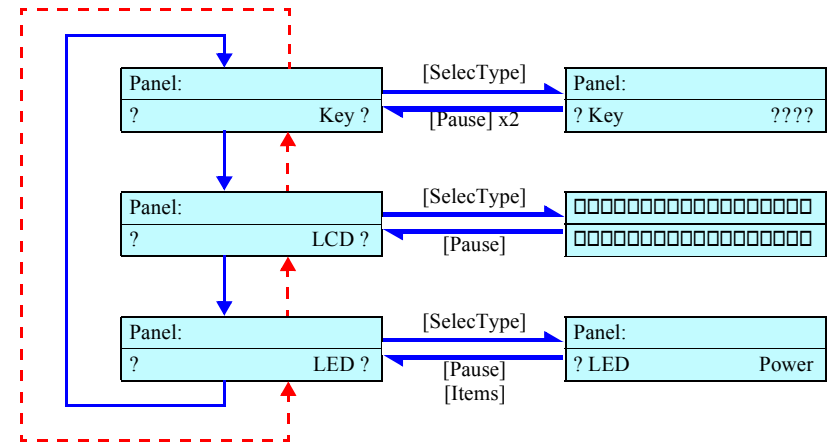

Figure 5-5. Menu Transition of Panel Test

5.2.2.3 Sensors

Sensor status is displayed on the panel.

- The numerals shown at the item “Paper” means that the paper thickness is as follows:
 - 00 : 0.3 mm or below in paper thickness
 - 01 : 0.4 mm ~ 0.8 mm in paper thickness
 - 11 : 0.9 mm or more in paper thickness
 - 10 : The lever is in the up position.

NOTE: When adjustment is required, see “5.2.3.1 Rear AD Adjustment (p.231)”.

- “INK NOT” indicates the absence of color ink cartridges. Each symbol displayed signifies that the corresponding color ink cartridge is absent.
- For Edge AD and Rear AD, the value shown around the center represents the ON-OFF difference and the value shown at right represents the ON level. The standard for accepting each AD value is as follows:
 - Rear AD: 40 or more in ON-OFF difference and 95 or less in ON level
 - Edge AD: 40 or more in ON-OFF difference and E0 ~ E8 in ON level

NOTE 1: For adjustment procedure, see “5.2.3.2 Edge AD Adjustment (p.232)” and “5.2.3.1 Rear AD Adjustment (p.231)”.

2: With Stylus Pro 7600, the item “TAKE UP” is not displayed.

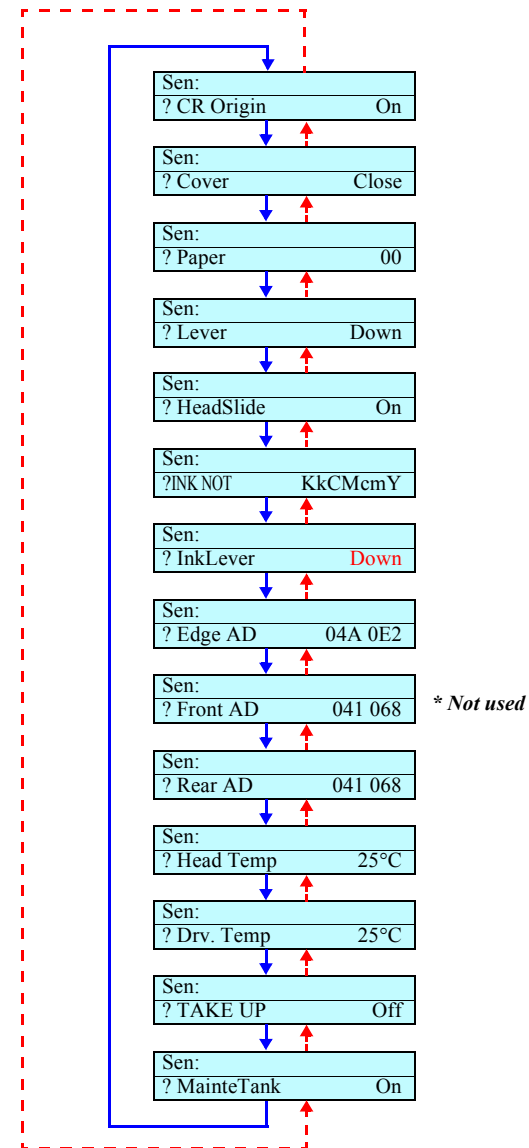

Figure 5-6. Menu Transition of Sensor Test

5.2.2.4 Encoder

The encoder values for CR shaft (carriage) and PF (form feed) are displayed on the panel. (See Figure 5-7)

- The value displayed represents the encoder pulse count.

5.2.2.5 Fan

Check to see if each fan operates. (See Figure 5-8)

NOTE: With Stylus Pro 7600, the item "Paper 3" (paper suction fan) is not displayed.

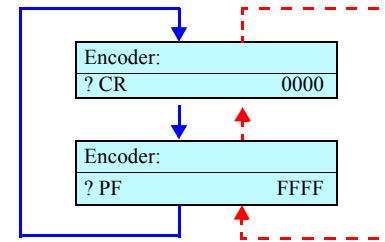

Figure 5-7. Menu Transition of Encoder Test

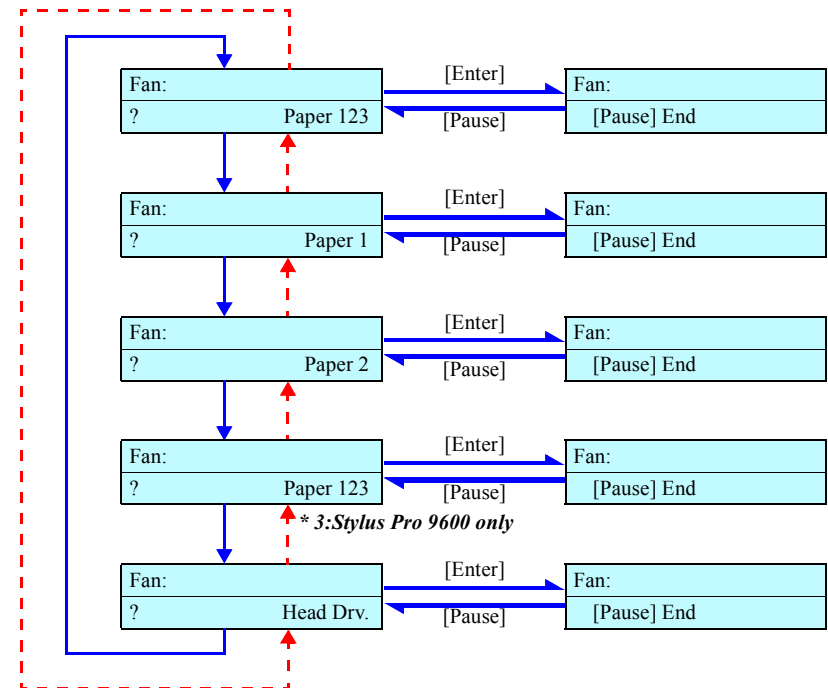

Figure 5-8. Menu Transition of Fan Test

5.2.2.6 Record

Check the record of maintenance of major faults.

The figure at right shows the menu of record. (See Figure 5-9)

MAINTENANCE RECORD

“Record: Maintenance” displays the record of maintenance. (See Figure 5-10)

Table 5-18.

WasteInk	Waste ink
Wiper	Wiping count
Rubing*	Rubbing count
Lever	Lever up count
Cover	Cover opening count
Ink Lever	Ink lever up count
CR Motor	CR motor round trip count
PF Motor	PF motor travel
Ink Tube*	Ink tube round trip count
Print Number	The number of printed sheets
Clening	Cleaning count
Fire B	K ink discharge count (in mega dots)
Fire LK	LK ink discharge count (in mega dots)
Fire C	C ink discharge count (in mega dots)
Fire M	M ink discharge count (in mega dots)
Fire LC	LC ink discharge count (in mega dots)
Fire LM	LM ink discharge count (in mega dots)
Fire Y	Y ink discharge count (in mega dots)
Cut	Cutting count
Cut Sole.	Cutter solenoid operation count
LockSolen*	Head lock solenoid operation count

Note "*": Not used

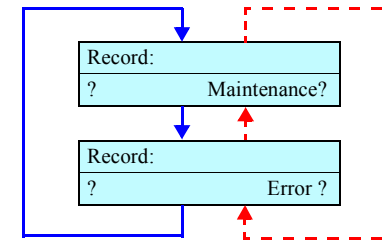

Figure 5-9. Menu Transition of Record

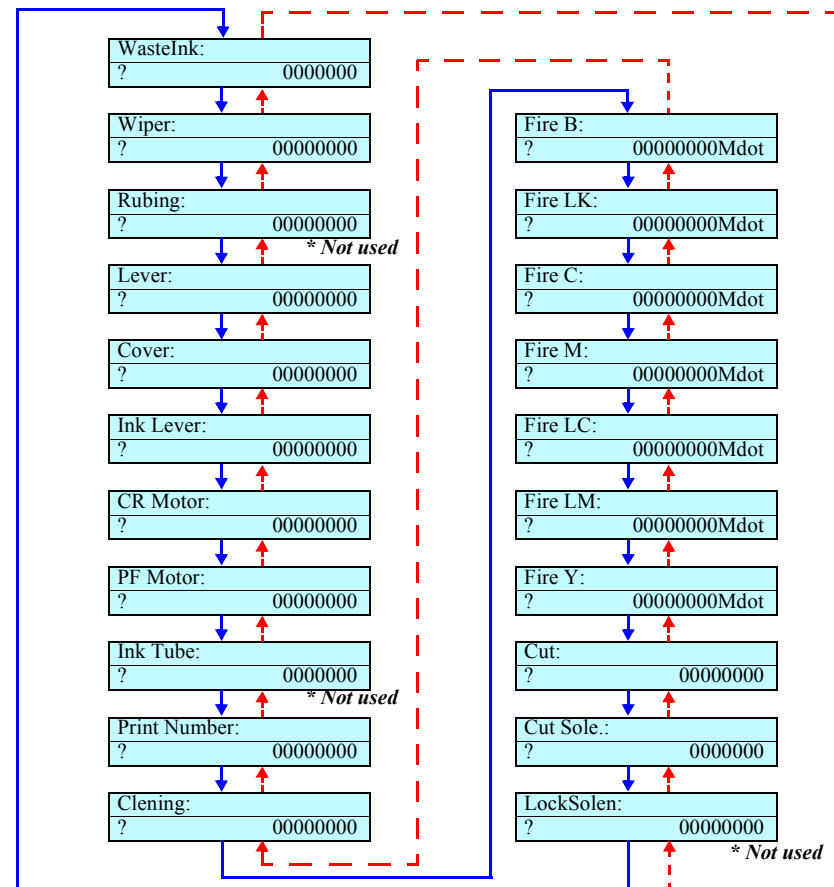

Figure 5-10. Menu Transition of Maintenance Record

RECORD OF ERRORS

The record of major errors (service call errors) can be checked. A maximum of 7 errors are displayed. (See Figure 5-11)

NOTE: CPU errors are not included.

5.2.2.7 CSIC

Information on each CSIC is displayed. (See Figure 5-12)

Menu transition for cartridge selection is shown at right.

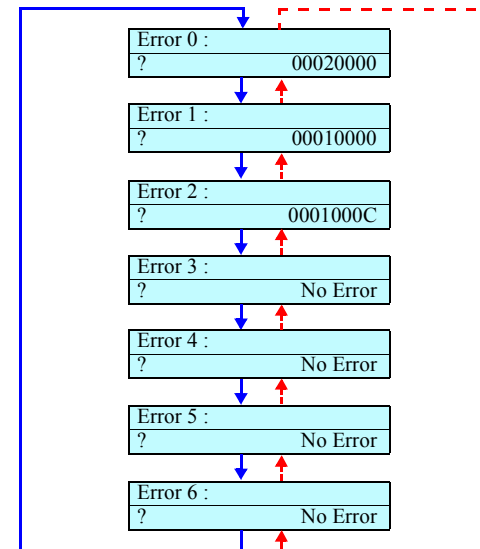

Figure 5-11. Menu Transition of Record of Errors

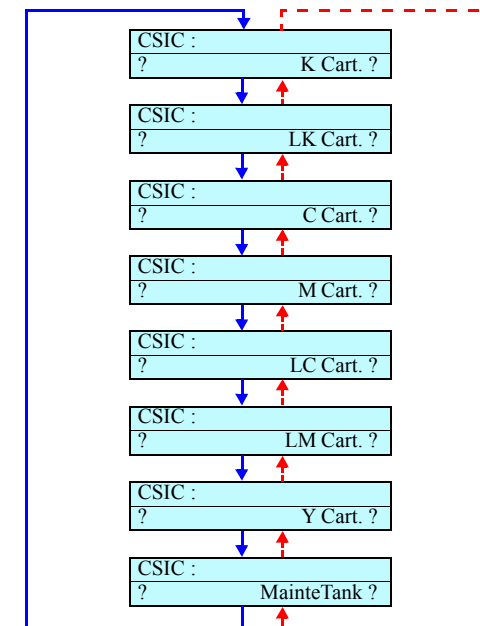

Figure 5-12. Menu Transition for Cartridge Selection

INTERNAL INFORMATION DISPLAY OF CSIC

Internal information on CSIC is displayed.

Figure 5-13 shows menu transition for internal information display of CSIC.

NOTE: The indications on the LCD mean as follows:
 00-27: Memory addresses (00H ~ 27H) in EEPROM of CSIC
 K: Ink cartridge of which information is available

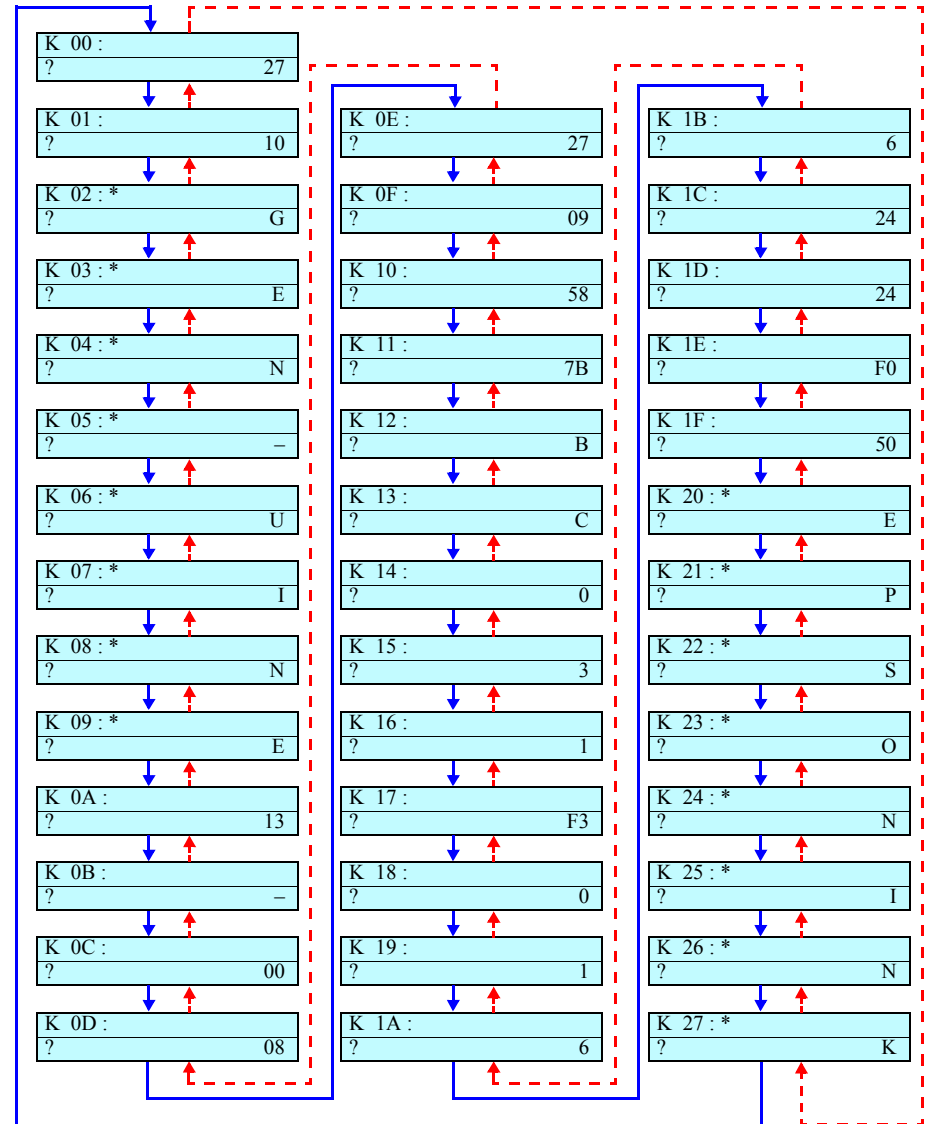

*Fixed information

Figure 5-13. Menu Transition for Internal Information Display of CSIC

5.2.2.8 Actuator

You can operate actuators. (See Figure 5-14)

CUTTER

The cutter is moved up and down by operating on the panel. (See Figure 5-15)

- Neither pressing the [Paper Feed +] key with “UP” displayed nor pressing the [Paper Feed -] key with “DOWN” displayed works. Upon passage of 60 seconds with the cutter in the down position, it will automatically move up.

5.2.2.9 Actuator 2

You can operate actuators. (See Figure 5-16)

- When you try to return to the top menu of test after execution of any item of Actuator 2, “Turn Power OFF” will be displayed.

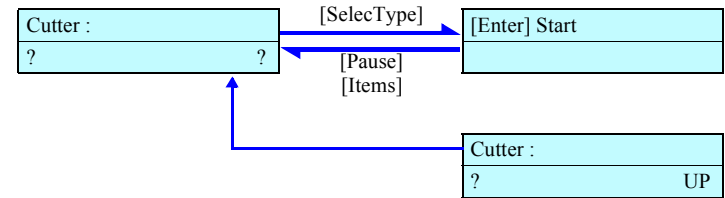

Figure 5-14. Menu Transition of Actuator

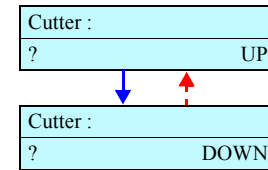

Figure 5-15. Menu Transition of Cutter

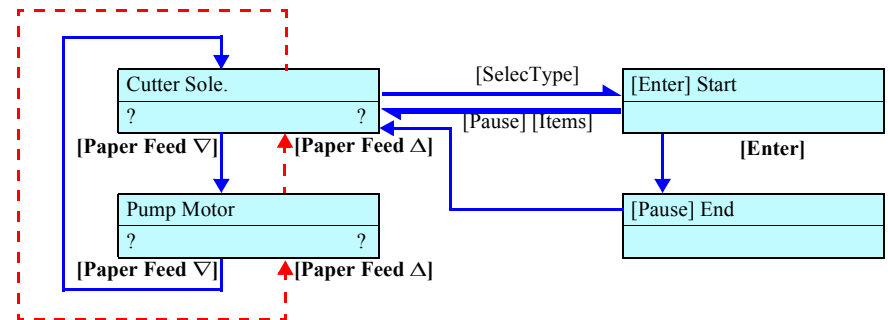

Figure 5-16. Menu Transition of Actuator 2

5.2.3 Adjustment

Make the mechanism adjustment (head slant) and the firmware parameter adjustment.

Table 5-19. Panel Setting Item List

Item	Description	See
Rear AD Adjustment	Make the AD adjustment of the rear sensor.	p. 231
Edge AD Adjustment	Make the AD adjustment of the edge sensor.	p. 232
Front AD Adjustment	(Not used)	—
Head Rank Input	Input the characteristic values for the installed head. After that, supply ink.	p. 233
D/A Compensation Value Write	(Not used)	p. 236
Head Nozzle Check	Check the print result for proper ink discharge from the head nozzles.	p. 237
Paper Skew Check	Perform paper feed, and check the degree of skew by sensor.	p. 238
Feed Correction + T&B	Make the printer perform printing and correct the paper feed rate (band feed).	p. 239
Top & Bottom	Adjust the paper top and bottom margins and the left margin.	p. 242
Automatic Mechanism Adjustment	(Not used)	—
Rear Paper Sensor Position	Using cut paper, determine the distance between the XF sensor and the XR sensor.	p. 243
Platen Position Adjustment	Adjust the sponge position of the platen.	p. 244
Platen Position Checking	Check the adjustment result of the sponge position of the platen.	p. 245
Cutter Adjustment	(Not used)	—
Slant Check	Make the printer perform printing and check the slant of the head. (Mechanism Adjustment)	p. 246
Round Trip Print Position Adjustment (Bi-D)	Make the printer perform printing and adjust the round trip printing position. (PG/1.2mm)	p. 248
Parameter Copying (Bi-D)	Copy the Bi-D adjustment value (PG/1.2mm) above onto Bi-D2 (PG=0.7mm) and Bi-D3 (PG=2.1mm).	p. 251
Round Trip Print Position Adjustment 2 (Bi-D2)	Make the printer perform printing and adjust the round trip printing position. PG/0.7mm	p. 251
Round Trip Print Position Adjustment 3 (Bi-D3)	Make the printer perform printing and adjust the round trip printing position. PG/2.1mm	p. 251
Round Trip Print Position (Bi-D Adjustment) Checking	According to the result of the round trip print position adjustment, shift the pattern by the theoretically required number of dots. Then print the pattern and make certain that the result of adjustment is proper.	p. 252
Head Gap Adjustment (Uni-D Adjustment)	Make the printer perform printing and adjust the one-way printing position.	p. 253

Table 5-19. Panel Setting Item List (continued)

Item	Description	See
Test Pattern Printing	Head nozzle checking and adjustment pattern (Input the serial number)	p. 255
Clean Head	Clean the tube and head using cleaning liquid.	p. 256
Counter Clear	Clear various software counters.	p. 257

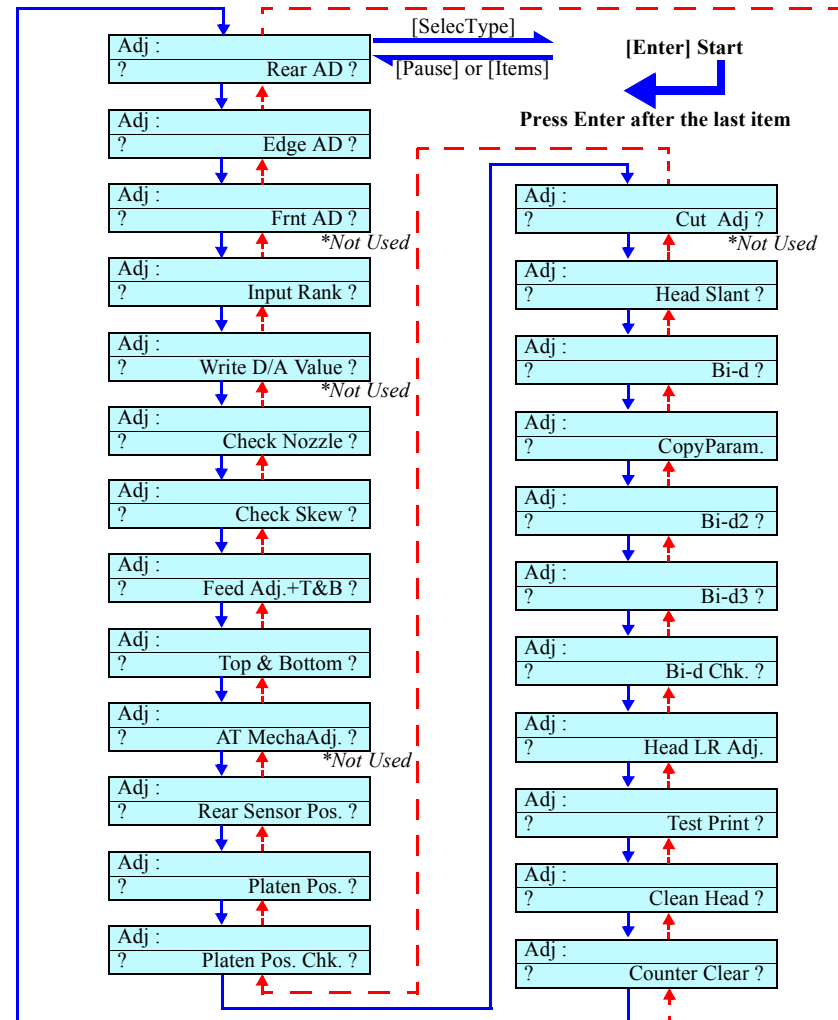

Figure 5-17. Adjustment Menu Transition

5.2.3.1 Rear AD Adjustment

The optimum value for resistance of the Rear Sensor is automatically detected and determined. (See Figure 5-18)

- The values displayed are “D/A adjustment value”, “ON-OFF difference” and “ON level” as named from left.
- Appropriate values
 ON-OFF difference: 040 or more
 ON level: 095 or less

NOTE: The appropriate values are represented in hexadecimal notation.

- Paper to be used:
 A3-size Kimoto Micro Tracing Paper #300 LMB #F751 (1057723)

ADJUSTMENT AND CHECKING PROCEDURE

1. Start the Self-diagnostic Function:
 Power OFF → [Paper Feed Δ]+[Paper Feed ∇]+[Cut/Eject] → Power ON
2. Set paper:
 Set a sheet of A3-size Kimoto Micro Tracing Paper #300 LMB #F751 (1057723) on the HP side.
3. Display “Adj: Rear AD”:
 [Paper Feed ∇] → [SelcType >] → [Paper Feed ∇] x2
4. Detect the adjusted values:
 [SelcType] → [Enter ↵]
5. Check the values for properness:
 Check that the values are within the respective ranges specified above. If they are not within the ranges, clean the sensor surface or replace it with a new one.

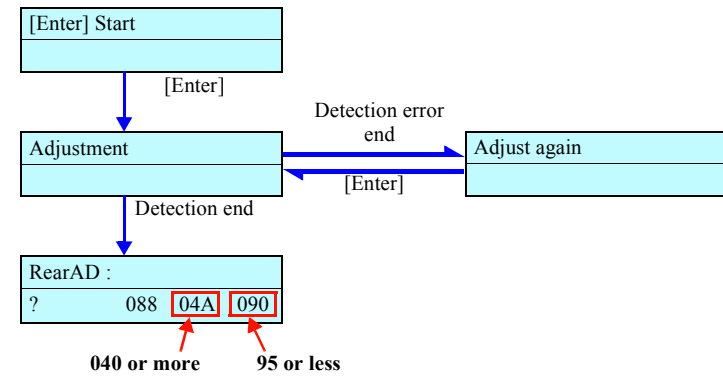

Figure 5-18. Menu Transition for Rear AD Adjustment

5.2.3.2 Edge AD Adjustment

The optimum value for resistance of the Edge Sensor is automatically detected and determined. (See Figure 5-19)

- The values are displayed in the order of “D/A adjustment value”, “ON-OFF difference” and “ON level” from left to right.
 - Appropriate values
 ON-OFF difference: 040 or more
 ON level: within 0E0 ~ 0E8
- NOTE: The appropriate values are represented in hexadecimal notation.*
- Paper to be used: A3 plain paper

ADJUSTMENT AND CHECKING PROCEDURE

1. Start the Self-diagnostic Function:
 Power OFF → [Paper Feed Δ] + [Paper Feed ▽] + [Cut/Eject] → Power ON
2. Set paper:
 Set A3-size plain paper on the HP side.
3. Display “Adj: Edge AD”:
 [Paper Feed ▽] → [SelectType >] → [Paper Feed ▽]
4. Move the CR Unit:
 By manual operation, move the Carriage so that the Edge Sensor is positioned at the right edge of the A3 plain paper.
5. Detect the adjusted values:
 [SelectType] → [Enter ↵]
6. Check the values for properness:
 Check that the values are within the respective ranges specified above. If they are not within the ranges, clean the sensor surface or replace it with a new one.

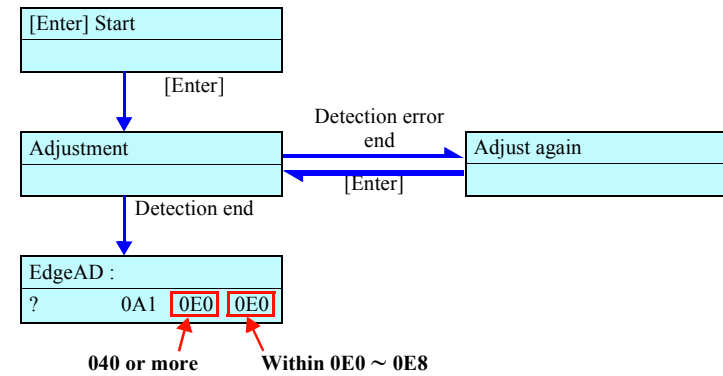

Figure 5-19. Menu Transition for Edge AD Adjustment

5.2.3.3 Input Rank

When the print head has been replaced, input as the head rank the information specific to the head for setting the optimum drive voltage.

(See Figure 5-20)

A label indicating a rank information code which consists of a numerical value representing the characteristic values of the head has been affixed to the head already mounted on the printer or the head newly installed (See Figure 5-24). Input this value and write it in the Flash memory.

CHECK POINT

When initial filling only is to be performed after replacing the Damper ASSY, select and execute “Initial charge” in “Cleaning” (p.259) menu.

5.2.3.3.1 QR Code Input

CHECK POINT

The dedicated QR code reader is necessary for “QR Code input”. On the service site, select and execute “Input on Panel”.

- Press [Pause] key to enter “Rank Input: QR Code”.
- After ink filling, the display returns to the adjustment top menu.
- Input correct values when an rank error has occurred.
The relationship between indications and errors is as follows:
 - “RankError (D/P)”: Both dye and pigment are wrong.
 - “RankError (D)”: Wrong rank for dye
 - “RankError (P)”: Wrong rank for pigment

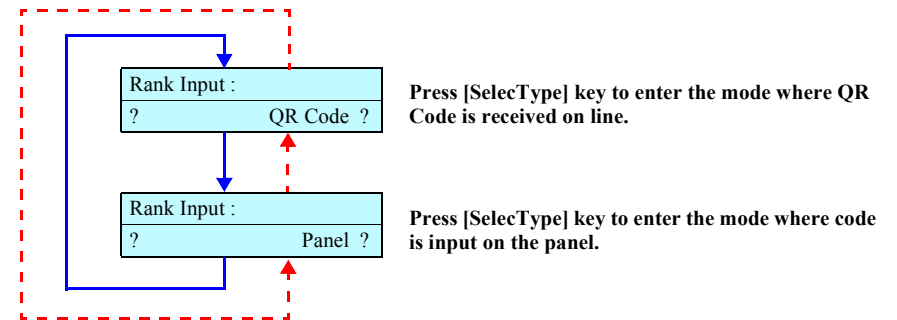

Figure 5-20. Menu Transition for Head Rank Input

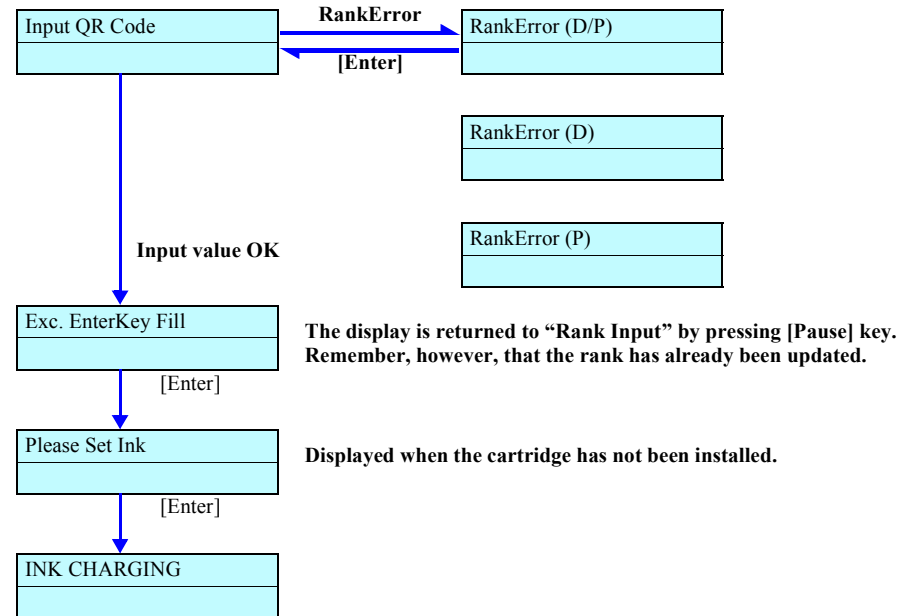

Figure 5-21. Menu Transition for QR Code Input

5.2.3.3.2 Input on Panel

In this mode, select an input type to input a code by operating on the panel.
 (See Figure 5-22)

INPUT LINE SELECTION

In this mode, select an input line on which you input the code by panel operation.
 (See Figure 5-23)

NOTE: For pigment code input, "Pigment-1" ~ "Pigment-3" are displayed.

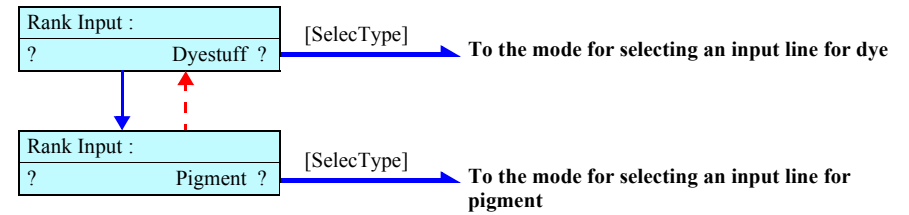

Figure 5-22. Menu Transition of Panel Input

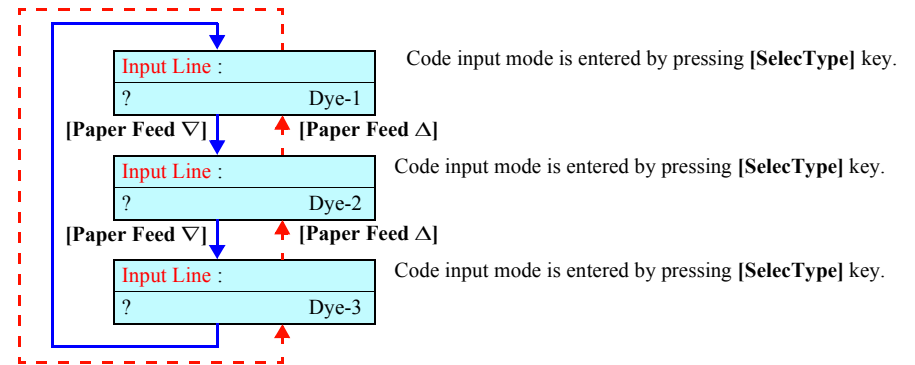

Figure 5-23. Menu Transition for Input Line Selection

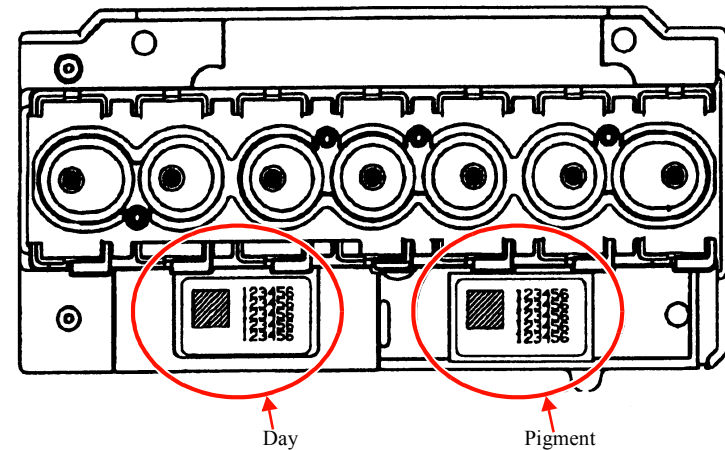

Figure 5-24. Head Code Label Position

□ Dye code input

In this mode, input a dye code by operating on the panel.
 The cursor is displayed at the position where a digit is currently input.
 (See Figure 5-25)

- Press [Cleaning] key to shift the cursor (pointing out the input item) to the right.
- The cursor moves to the left end when [Cleaning] key is pressed at the right end.
- After ink charge, the display returns to the adjustment top menu.
- Press the [Pause] key to return to the previous level in the hierarchy. In doing so, note that the input code is valid but it has not been registered yet.
- The cursor skips the item displayed with “\”.
- At input for “Dye-1” or “Dye-2”, press the [Enter] key to enter the input line selection mode, which is the immediately upper level in the hierarchy.

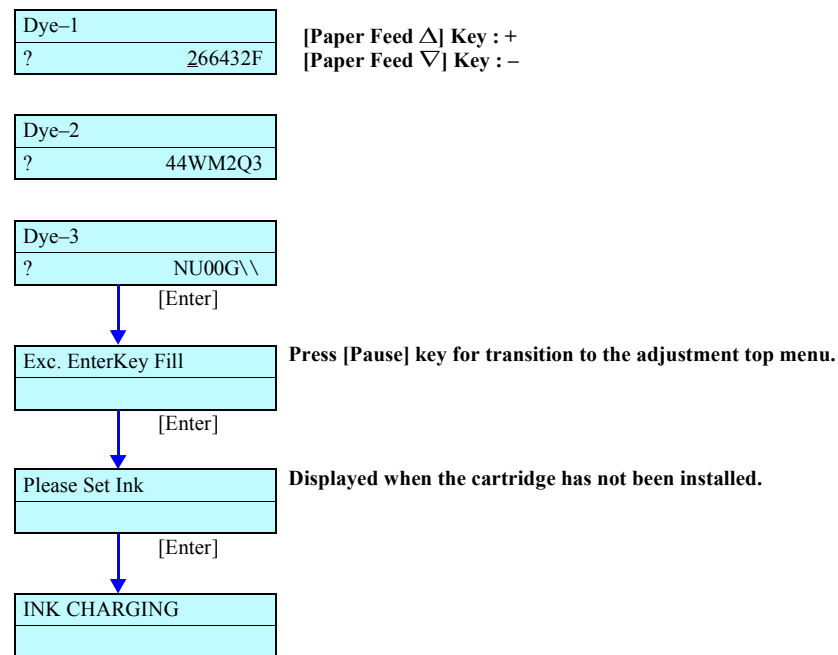

Figure 5-25. Menu Transition of Code Input

- Pigment Code Input
- After ink filling, the display returns to the adjustment top menu. Pigment Code Input
 - In this mode, input a pigment code by operating on the panel.
 - The cursor is displayed at the position where a digit is currently input.
 - Press [Cleaning] key to shift the cursor (pointing out the input item) to the right.
 - The cursor moves to the left end when [Cleaning] key is pressed at the right end.
 - After ink charge, the display returns to the adjustment top menu.
 - Press the [Pause] key to return to the previous level in the hierarchy. In doing so, note that the input code is valid but it has not been registered yet.
 - The cursor skips the item displayed with “\”.
 - At input for “Pigment-1” “Pigment-2” or “Pigment-3”, press the [Enter] key to enter the input line selection mode, which is the immediately upper level in the hierarchy.

5.2.3.4 Write D/A Value



Stylus Pro 7600/9600 does not incorporate this function. Do not try to execute this operation on the service site.

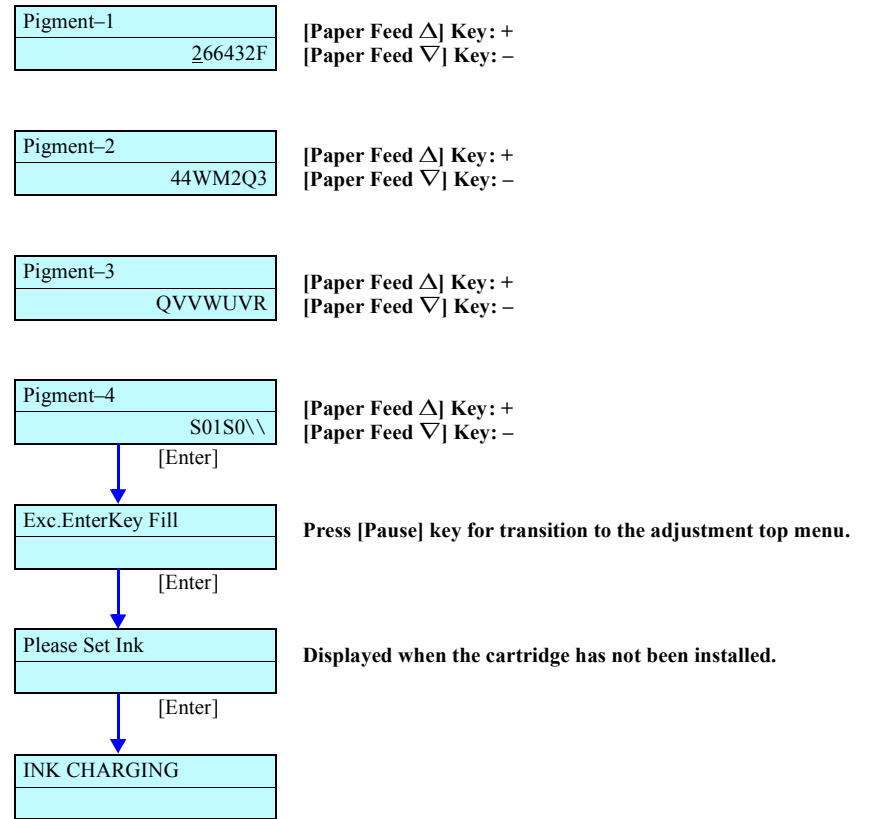

Figure 5-26. Menu Transition of Code Input

5.2.3.5 Check Nozzle

Check the print result to see if the head nozzles discharge ink properly and if there is any alignment error. If ink discharging from the nozzles is faulty or there is any alignment error, execute cleaning in this item and perform checking again. If there is no ink remaining, the printer requests the installation of ink cartridges. When paper has been set and there is ink, the printer prints the head nozzle check pattern.



Printing operation is carried out even when the ink cartridges have been installed but ink filling has not been performed.

Head Nozzle Check Pattern

■ Check Item

- Nozzle ink discharge (skipping, not continuous, meandering)
- Satellite
- Timing fence
- Vertical nozzle alignment check
- Horizontal nozzle alignment check

Table 5-20. Pattern

Pattern	Description
Nozzle ink discharge <i>(See Figure 5-28)</i>	The pattern is printed in the order of K/C/M/Y/LC/LM/LK from left to right.
	Pattern drawing method 360dpi, Uni-D, VSD1, 240CPS, Large
	HeadRank ID: 266432F 06E424E 44WM2Q3 4BUTWTU NU00G QVVWUVR S01S0
Horizontal nozzle alignment check <i>(See Figure 5-29)</i>	The pattern is printed in the order of K/LK/C/LC/M/LM/Y from left to right.
	Pattern drawing method 360dpi, Uni-D, 240CPS, VSD1, Large
	360dpi, Uni-D, 240CPS, VSD2, Large
	360dpi, Uni-D, 240CPS, VSD2, Small 360dpi, Uni-D, 190CPS, VSD4, Large
Vertical nozzle alignment check <i>(See Figure 5-30)</i>	The pattern is printed in the order of K/LK/C/LC/M/LM/Y from left to right.
	Pattern drawing method 360dpi, Uni-D, 240CPS, VSD1, Small/Middle/Large
	360dpi, Uni-D, 240CPS, VSD2, Small/Middle/Large 360dpi, Uni-D, 190CPS, VSD4, Small/Middle/Large

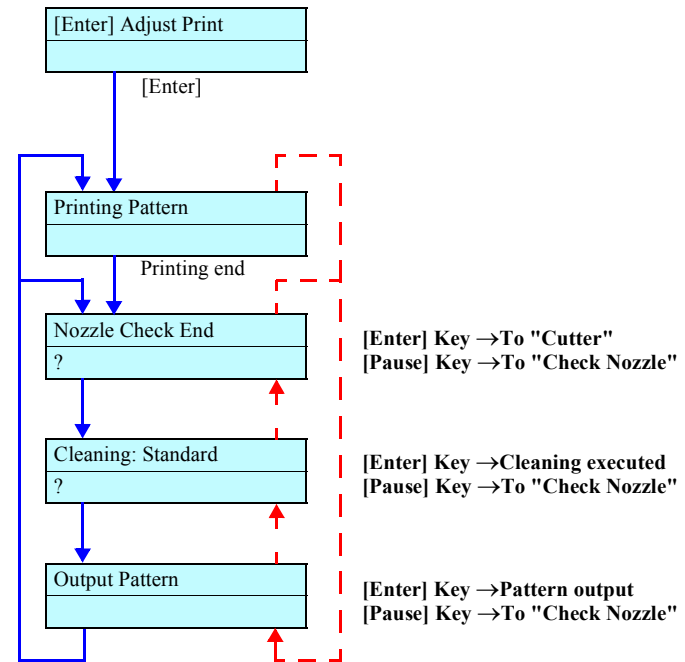

Figure 5-27. Menu Transition for Head Nozzle Check



Figure 5-28. Pattern (Nozzle Ink Discharge Check)



Figure 5-29. Pattern (Horizontal Nozzle Alignment Check)



Figure 5-30. Pattern (Vertical Nozzle Alignment Check)

5.2.3.6 Check Skew

Feed paper by a specified distance (specify the distance on the panel), read the paper edge position before and after paper feed with the edge sensor and check the difference between the two readings. (See Figure 5-31)

After completion of initial operation, input the value for paper feed distance. Then the Edge Sensor will detect the paper left edge (capping side) and the printer will display the difference between the positions before and after paper feed.

If a paper recognition error before or after paper feed occurs or if the Rear Sensor detects “No Paper” during paper feed, the display shows paper error. Then press the appropriate key to leave this item.

NOTE: The printer will leave this item once the [Pause] key is pressed on the control panel while the printer is not processing.

- At the first detection of the paper left edge, the reference position for paper skew judgment is determined in the firmware.
- The “Paper Out” LED blinks or lights up if the paper detection error has occurred. In such cases, raise the lever once and then execute the same operation again.
- Press the [Pause] key for transition to “Adj: Check Skew”.
- No panel key works during execution of skew checking.

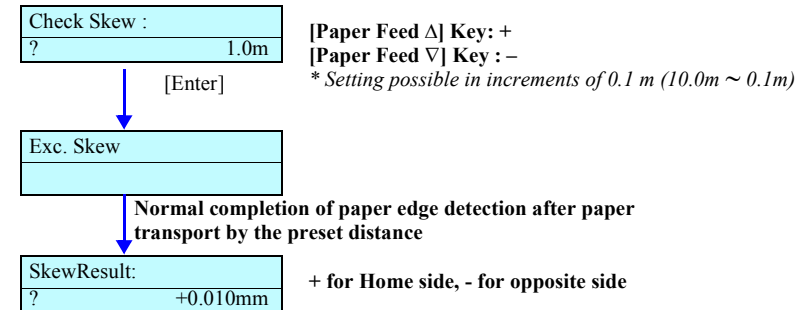

Figure 5-31. Menu Transition for Skew Checking

CHECK POINT



When the skew check result is “99.999mm”, the paper is in the following conditions. Clear the cause and execute the check again.

1. The paper width detection indicates that one of the right and left edge positions of the paper is different from that by the previous detection by ± 3 mm or more.
2. When the head is at the home position, the distance from the row of K nozzles to the paper detected position on the home side is 142.0 mm or less. (The paper is too close to the home position.)

Lever up or cover opening was performed during paper feed operation.

5.2.3.7 Feed Correction + T&B Adjustment

For paper transport, correct the distance and adjust the top & bottom margins and side margin (printing start position). (See page 241)

- Feed Adjustment (Paper feed distance compensation):
 Make the printer print a line in the paper feed direction, input the distance and determine the PF encoder resolution inside the firmware.
 The reference length for this determination has been set to 1 m.
 (Only the input of a compensation value without printing is possible.)
 The input value, handled as the compensation value, is written in the Flash ROM.
 - Resolution: 0.1mm
- Adj Top & Bottom:
 Conduct printing and paper cutting and input the distances between the Front Sensor and the Head, between the Cutter and the Head and between the Edge Sensor and the Head (writing start position).
 The input value, handled as the compensation value, is written in the Flash ROM.
 - Resolution: 0.1mm
- Side Margin Adjustment (Print Start Position Adjustment):
 Conduct printing and paper cutting, then measure and input the side margin.
 The input value, handled as the compensation value, is written in the Flash ROM.
 - Adjustment resolution: 0.1mm

Menu transition is shown at right and adjustment patterns are shown on the next page.

- Press the [Pause] key on the compensation value input screen, and the display will change to “Feed Adj.+T&B”.
- Press the [Pause] key on the “Top Length” or “Bottom Length” input screen, and the display will change to the “Bottom Length” or “Side Margin” input screen, respectively.
- “Top Length”, “Bottom Length” and “Side Margin” can be adjusted only in the T&B adjustment mode for the first printing.

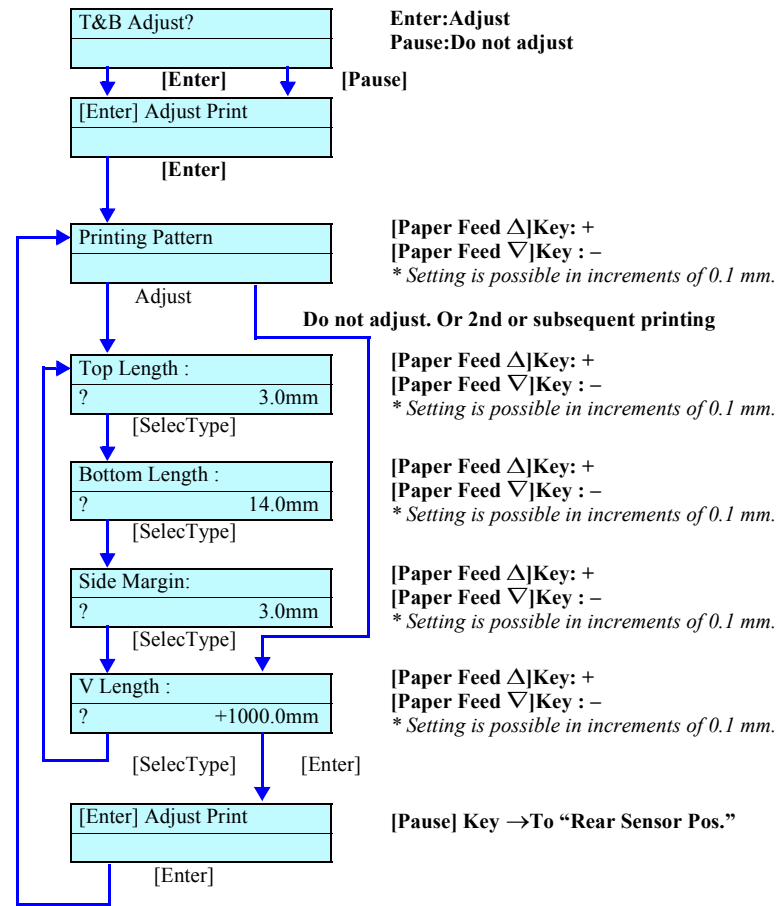

Figure 5-32. Menu Transition for Feed Correction +T&B Adjustment

- Adjustment pattern
 - Adjustment items
 - Top margin (Front Sensor position)
 - Bottom margin (cutter position)
 - Side margin (Writing start position)
 - Paper feed length:
 - 1000 mm
 - Pattern drawing method:
 - Length: 1000mm
 - Printing direction: Uni-D
 - Resolution: 360 dpi
 - Printing speed: 240 CPS

Table below specifies the positions where the NormalDot2 vertical line patterns are drawn.

Table 5-21. Positions where Vertical Line Patterns Are Drawn

Coordinate in units of 360 dpi	In mm
0	0
1417	About 100
2834	About 200
4251	About 300
5669	About 400
7086	About 500
8583	About 600
9921	About 700
11338	About 800
12755	About 900
14173	About 1000

FEED CORRECTION + T&B ADJUSTMENT

1. Start the Self-diagnostic Function:
Power OFF → [Paper Feed Δ]+[Paper Feed ▽]+[Cut/Eject] → Power ON
2. Display “Adj: Feed Adj.+T&B”:
[Paper Feed ▽] → [SelectType >] → [Paper Feed Δ] x6
3. Print the pattern.
[SelectType >] → [Enter ↵] when “[Enter] Adjust Print” is displayed (See Figure 5-32)
4. Measure the top margin:
Using a measuring rule, measure the top margin. Input the measured value on the panel.
5. Measure the bottom margin:
Using a measuring rule, measure the bottom margin. Input the measured value on the panel.
6. Measure the side margin:
Using a measuring rule, measure the side margin. Input the measured value on the panel.
7. Measure the feed correction value:
Using a measuring rule (1000 mm) and the scale stopper, measure the longitudinal line length. Input the measured value on the panel.

CHECK POINT

- The central print pattern among the patterns as shown above is intended for use as a datum line on which the measuring rule is to be placed.
- Even if you have left the “Feed Correction + T&B Adjustment” mode by mistake, you can restore the relevant adjustment display without reprinting the pattern, by pressing [Paper Source <] when “[Enter] Adjust Print” is displayed.

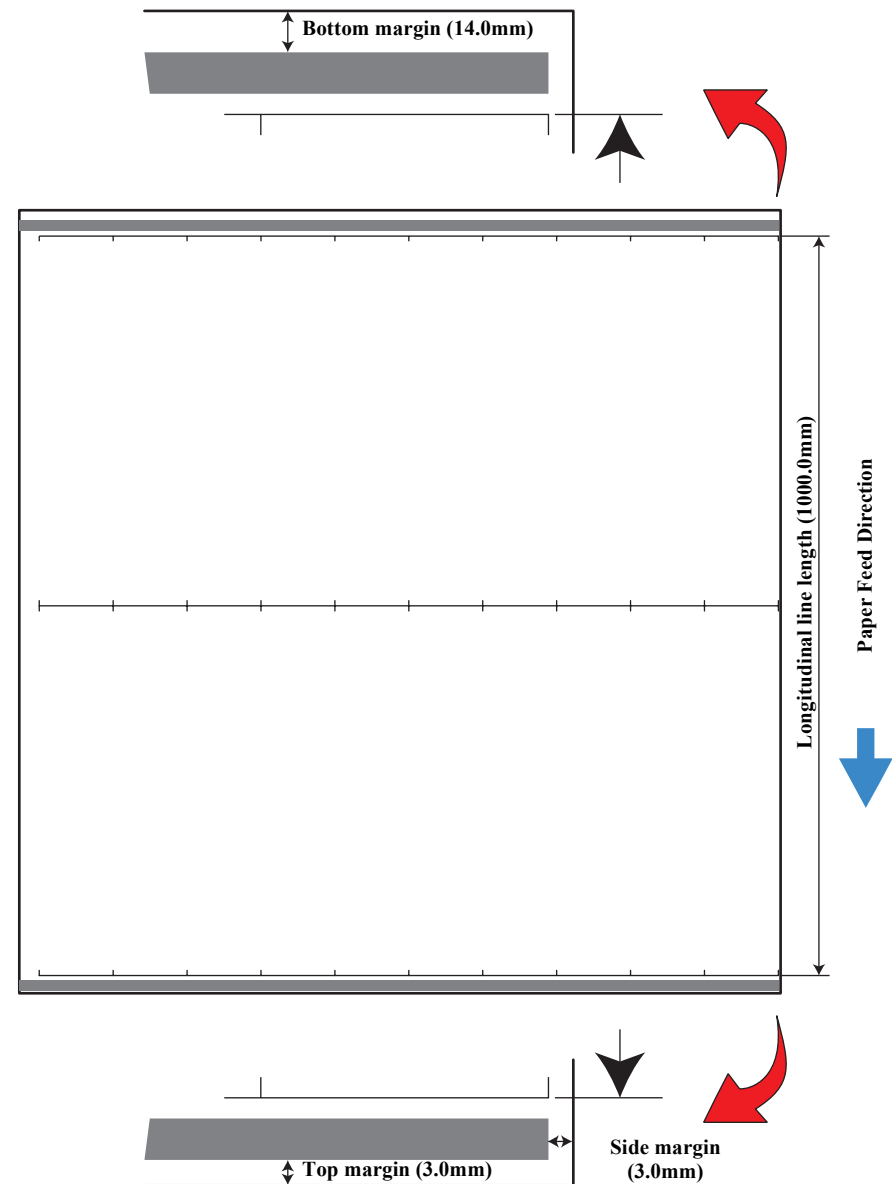

T_B01.eps

Figure 5-33. Print Pattern for Feed Correction + T&B Adjustment

5.2.3.8 Top & Bottom Adjustment

Conduct printing and paper cutting and input the distances between the Front Sensor and the Head, between the Cutter and the Head and between the Edge Sensor 0 and the Head (printing start position) to adjust the top, bottom and side margins.

- Press the [Pause] key on the compensation value input screen, and the display will change to “Top and Button”.
 - Press the [Enter] key on the input screen for “Top Length” or “Bottom Length”, and the display will change to the input screen for “Bottom Length” or “Side Margin”, respectively.
 - Press the [Enter] key on the input screen for “Side Margin”, and the display will change to “Rear Sensor Position”.
- Correction pattern of distances between the Front Sensor and the Head, between the Cutter and the Head
- Adjustment items:
 - Top margin (Front Sensor position)
 - Bottom margin (cutter position)
 - Side margin (printing start position)
 - Printing method: Black 1 pass, Uni-D mode 180 dpi
 - Pattern drawing method:

Printing direction:	Uni-D
Resolution:	360dpi
Printing speed:	240CPS
Dot:	NormalDot2

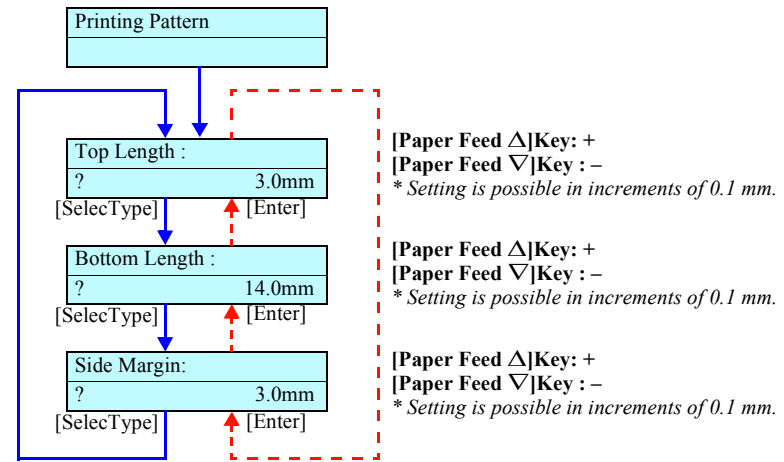
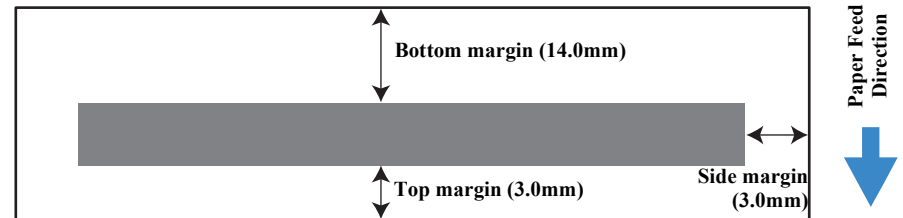

Figure 5-34. Menu Transition for Top & Bottom Adjustment



T_B02.eps

Figure 5-35. Print Pattern for Top & Bottom Adjustment

5.2.3.9 Rear Sensor Position

Make this adjustment to detect the length of cut paper correctly.

To ensure a maximum printable area relative to the paper tail end, adjust the Rear Sensor position inside the firmware with the nozzle position as the reference.

Set an A3 sheet in the portrait position, make the printer draw a horizontal line (black 1-dot line) at 14 mm from the sheet tail end. Then measure the distance from the sheet tail end to the line and input the measured value as the compensation value.

The input value, handled as the compensation value, is written in the Flash ROM.

- Resolution: 0.1mm
- Pattern drawing method: 360dpi, Uni-D, 240CPS, NormalDot2

NOTE 1: This adjustment is necessary in the manufacturing process. After that, however, execution of this item is not necessary even once Feed Correction is made.

2: When this item is selected, the printer requests setting of cut paper irrespective of the presence or absence of paper.

- As the Rear Sensor position, measure the distance between the sheet tail end and the drawn line and input the measured value.
- Press the [Enter] key on the “Rear Sensor Pos.” input screen, and the display will change to “Test Print”.

REAR SENSOR POSITION ADJUSTMENT PROCEDURE

1. Start the Self-diagnostic Function:
Power OFF → [Paper Feed Δ]+[Paper Feed ∇]+[Cut/Eject] → Power ON
2. Display “Adj: Rear Sensor Pos.”:
[Paper Feed ∇] → [SelecType >] → [Paper Feed Δ] x5
3. Print the pattern:
Set a sheet of A3-size plain paper (portrait) and press [Enter ↵]. (See Figure 5-36)
4. Measure the distance:
Using a measuring rule, measure the distance. Input the measured value on the panel. (See Figure 5-37)

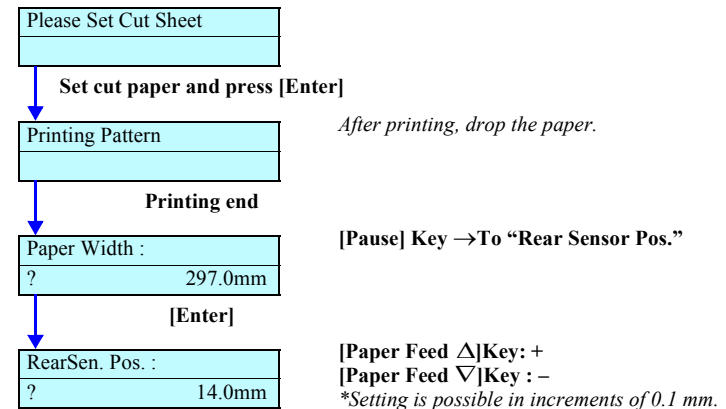

Figure 5-36. Menu Transition for Rear Sensor Position Adjustment

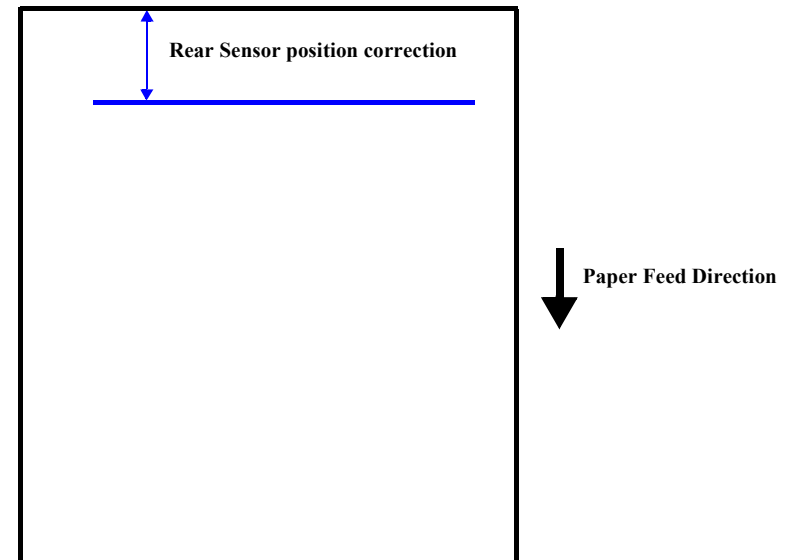

Figure 5-37. Rear Sensor Position Adjustment Pattern

5.2.3.10 Platen Position (Sponge Position) Adjustment

Detect the position of each sponge on the platen. (See Figure 5-38)

- For Platen R, input the deviation of the printed pattern from the left end of the frame in which the sponge nearest to the 1st home is embedded.
- For Platen L, input the deviation of the printed pattern from the left end of the frame in which the 7th sponge counted from the home for Stylus Pro 7600 or the 9th sponge for Stylus Pro 9600 is embedded.
- Input a negative value for a deviation toward the home or a positive value for a deviation toward the side opposite to the home.
- Pattern drawing method: 360dpi, Uni-D, 240CPS, VSD2, Large

PLATEN POSITION (SPONGE POSITION) ADJUSTMENT PROCEDURE

1. Start the Self-diagnostic Function:
Power OFF → [Paper Feed Δ]+[Paper Feed ▽]+[Cut/Eject] → Power ON
2. Display “Adj: Sponge Pos.”:
[Paper Feed ▽] → [SelecType >] → [Paper Feed Δ] x4
3. Print the pattern:
[Enter ↵] x2
4. Measure the platen position R:
Using a measuring rule, measure the distance from the left end of the frame in which the sponge nearest to the 1st home is embedded to the longitudinal line of the printed pattern.
Input the measured value on the panel.(See Figure 5-39)
5. Measure the platen position L:
Using a measuring rule, measure the distance from the left end of the frame in which the 7th sponge counted from the home for Stylus Pro 7600 or the 9th sponge for Stylus Pro 9600 is embedded to the longitudinal line of the printed pattern.
Input the measured value on the panel.(See Figure 5-39)

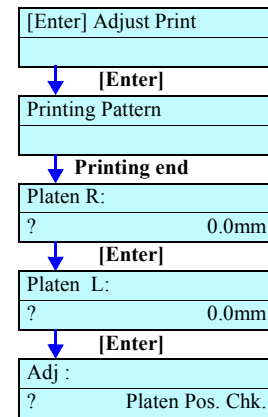

[Paper Feed Δ]Key: +
[Paper Feed ▽]Key: -
*Setting is possible in increments of 0.1 mm.

[Paper Feed Δ]Key: +
[Paper Feed ▽]Key: -
*Setting is possible in increments of 0.1 mm.

Figure 5-38. Menu Transition for Platen Position Adjustment

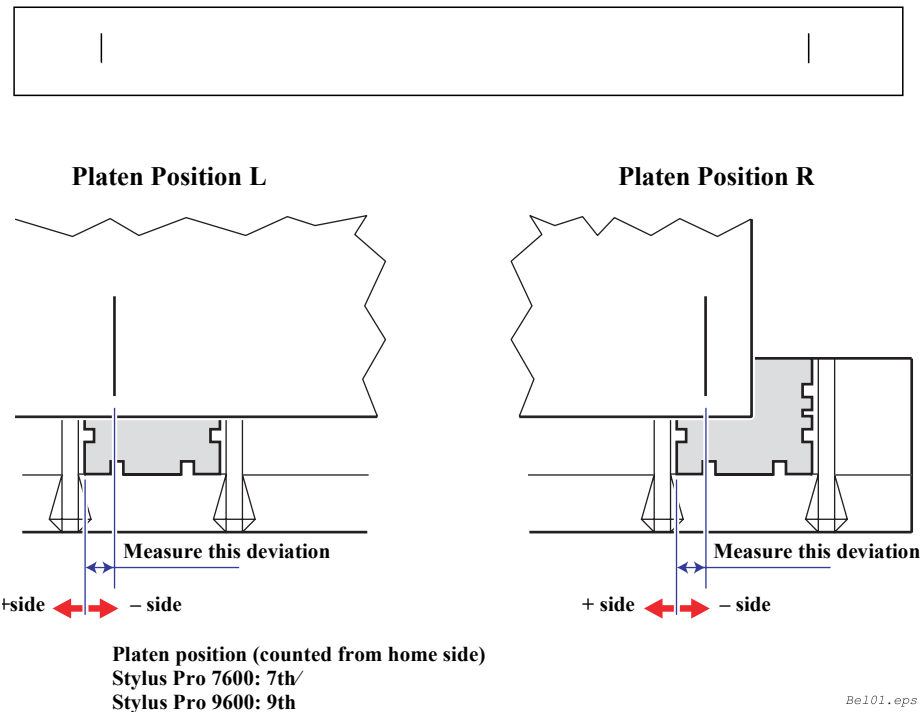
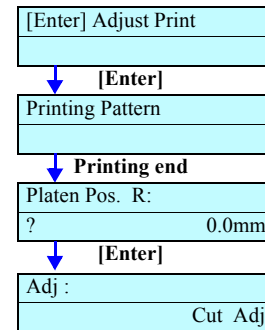

Figure 5-39. Print Pattern for Platen Position Adjustment

5.2.3.11 Platen Position Checking

Check the adjusted position of each sponge on the platen.

- Make certain that the printed pattern agrees with the right and left positions of each sponge position.
- Pattern drawing method: 360dpi, Uni-D, 240CPS, VSD2, Large



[Paper Feed Δ]Key: +
 [Paper Feed ∇]Key: -
 *Setting is possible in increments of 0.1 mm.

Figure 5-40. Menu Transition for Platen Position Checking

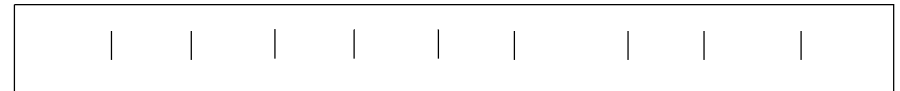

Figure 5-41. Print Pattern for Platen Position Checking

5.2.3.12 Head Slant Checking

Check the print result to see if the head is slanting.
 If there is a slant, make the “Head Slant Adjustment (Mechanical Adjustment)” (p.247).

- Slant Check Pattern
 - Check Item: Head slant
 - Pattern drawing method: 360dpi, Uni-D, 240CPS, VSD2, small
- Adjustment Resolution: 12µm or less
- Adjustment Range: 38 steps

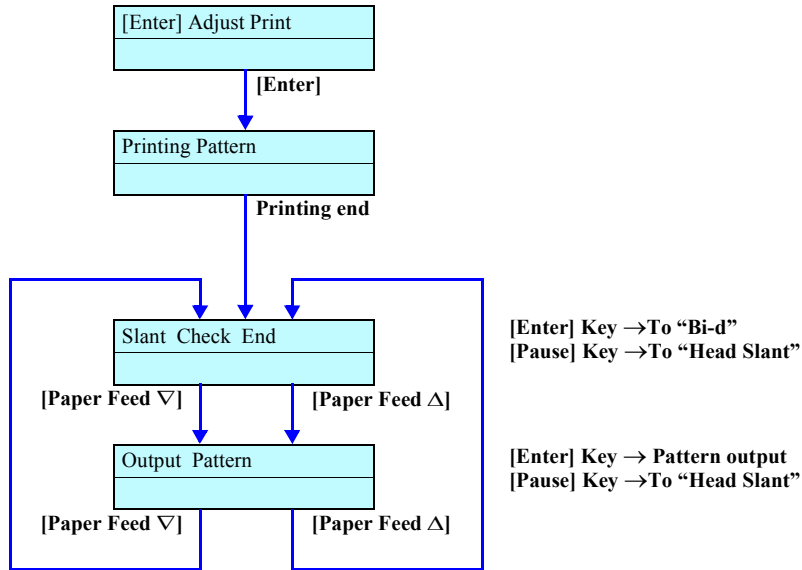

Figure 5-42. Menu Transition of Head Slant

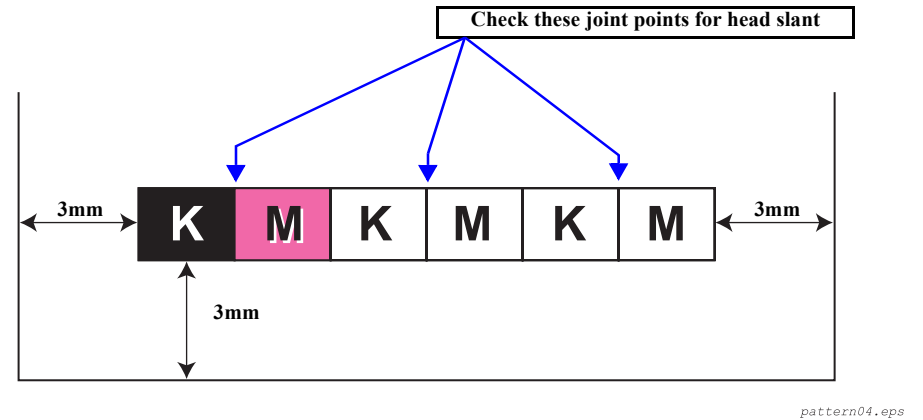

Figure 5-43. Slant Check Pattern

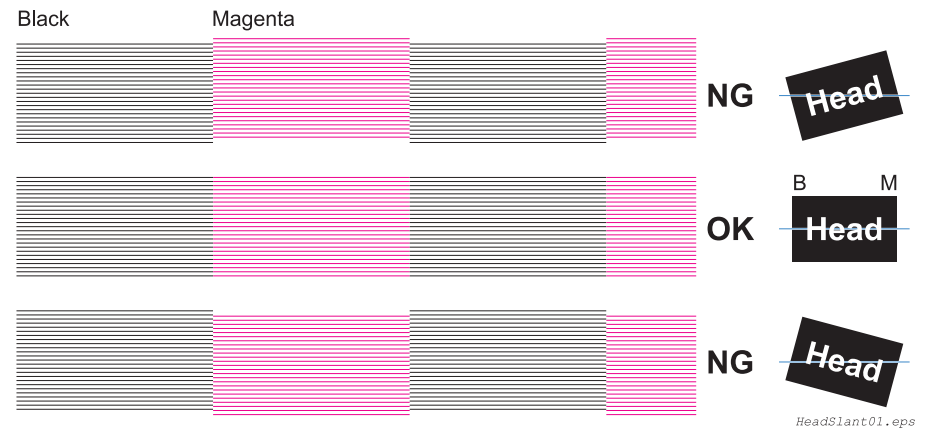

Figure 5-44. Head Slant Check Printout

HEAD SLANT CHECKING PROCEDURE

1. Start the Self-diagnostic Function:
Power OFF → [Paper Feed Δ]+[Paper Feed ▽]+[Cut/Eject] → Power ON
2. Display “Adj: Head Slant”:
[Paper Feed ▽] → [SelecType>] → [Paper Feed ▽] x8
3. Print the pattern.
4. Check the pattern: (See Figure 5-43)
Check to see if the black horizontal lines and the magenta horizontal lines are not in alignment. When they are in alignment, leave the head slant checking mode by pressing the [Paper Source] button two times. If they are not in alignment, follow the procedure as described below.

HEAD SLANT ADJUSTMENT (MECHANICAL ADJUSTMENT)

1. After printing the head slant check pattern, with “Do you correct slant?” displayed on the LCD, move the Carriage Unit to an appropriate place for work.
2. Loosen the right and left screws for the Head Holding Plate. (See Figure 5-45)
3. Move the Head Adjustment Lever in consideration of the output pattern. (See Figure 5-46)
4. Tighten the left screw for the Head Holding Plate and move the Carriage Unit to the home position.



■ Do not forget to tighten the two screws for the Head Holding Plate.

■ After making the head slant adjustment, be sure to return the Carriage Unit to the home position. If you proceed to the next step (Printing the pattern) with the Carriage Unit remaining in the place for work, the cutter edge can be damaged.

5. Print the pattern again, check to see if there is any misalignment and if any, repeat the adjustment from step 1.

CHECK POINT

Head motion by Head Adjustment Lever operation:
Lever Up: Magenta → lower / Black → rise
Lever Down: Magenta → rise / Black → lower

Figure 5-45. Head Slant Adjustment 1/2

Figure 5-46. Head Slant Adjustment 2/2

Adjustment

Self-diagnostic Function

247

5.2.3.13 Round Trip Print Position Adjustment (Bi-D Adjustment)

Adjust the round trip print position.

Make adjustments of “240CPS VSD1”, “240CPS VSD2” and “190CPS VSD4” for each color. This Bi-D adjustment is of PG=1.2mm. For PG=0.7mm (Bi-D2) and PG=2.1mm (Bi-D3), make adjustment in other menus, as required.

Store the adjustment values for each line of nozzles (21 kinds of values) in the Flash ROM.

For adjustment, conduct Bi-D printing and from the print results, input the difference between the CW print position and the CCW print position.

The procedure and print patterns for round trip print position adjustment are shown on the next page.

Table 5-22. Adjustment Item List

Item	Contents
BiD 240,V1	Bi-D Adjustment 240CPS VSD1
BiD 240,V2	Bi-D Adjustment 240CPS VSD2
BiD 190,V4	Bi-D Adjustment 190CPS VSD4

- Adjustment resolution: 8.8 μm
- Adjustable range: ± 96 step adjustment possible



- Be sure to make adjustment for K first and then for other colors.
- After adjustment, be sure to perform “Round Trip Print Position (Bi-D Adjustment) Checking (p.252)”.

- Press the [Enter] key with “***K PRN” displayed, and the K pattern will be printed.
- Press the [Enter] key with “***COL PRN” displayed, and the block pattern will be printed in colors other than K.
- When “***V1 K” is displayed, input the adjustment value for K (-96 ~ +96).
- When each of “***V1 K2” ~ “***V1 Y” is displayed, input the pattern number (0 ~ 8) for the aligned pattern.
- Press the [Enter] key with “BiD End” displayed, and the mode changes to “Adj: Bi-d Chk.”

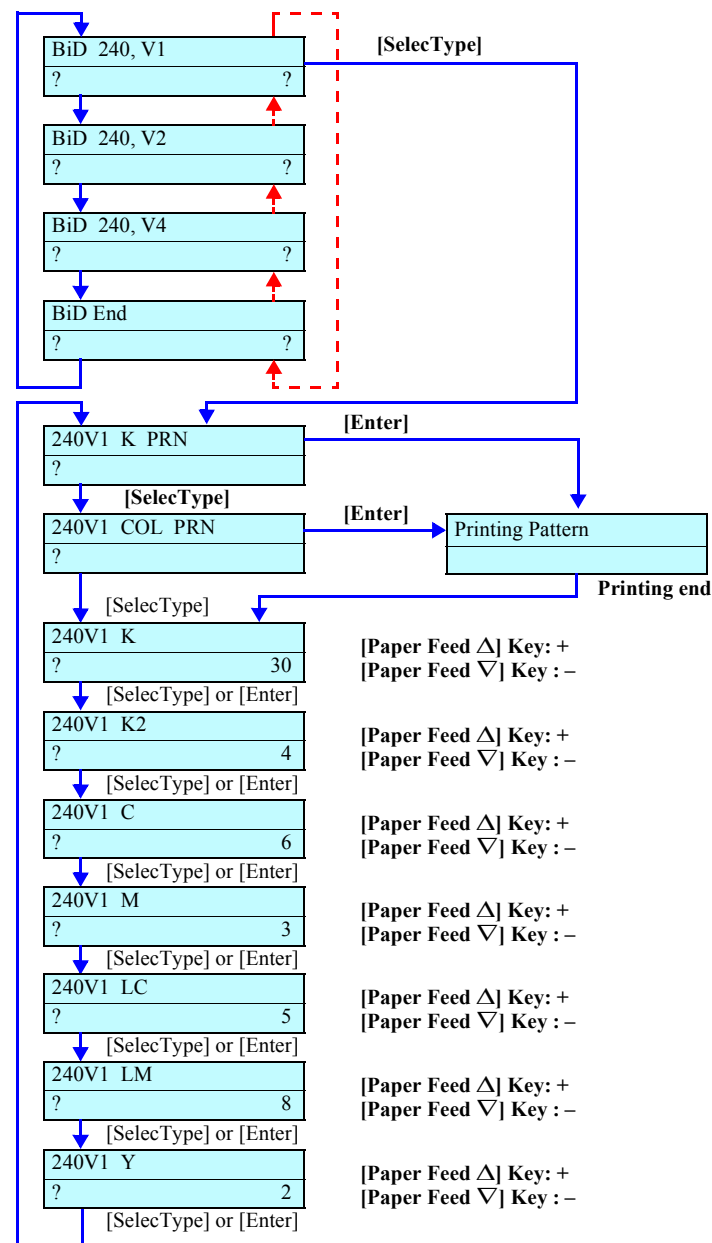

Figure 5-47. Menu Transition for Bi-D Adjustment

BI-D ADJUSTMENT PROCEDURE

1. Start the Self-diagnostic Function:
Power OFF → [Paper Feed Δ]+[Paper Feed ▽]+[Cut/Eject] → Power ON
2. Display “Adj: Bi-d”:
[Paper Feed ▽] → [SelcType >] → [Paper Feed ▽] x9
3. Print the 240, V1 black line pattern:
Press [Enter ↵] when “240V1 K PRN” is displayed. (See Figure 5-47)
4. Check the test pattern (240, V1 K)
Check to see if the line by the first pass and the line by the second pass are not in alignment.
When they are in alignment, proceed to the next step. If they are not in alignment, make the adjustment by referring to the procedure described below. (See Figure 5-49)

□ K (Black Line) Adjustment Procedure

1. Display the value input screen “240V1 K: xx”:
After the test pattern has been output, press [SelcType >] one time when “240V1 COL PRN” is displayed on the LCD.
2. Input the value:
In consideration of the output pattern, input a value in the range of +99~-99 and press [Enter ↵].
3. Output the pattern again:
[SelcType >] → [SelcType >] → [Enter ↵]
4. Check the pattern:
Check the output pattern and repeat the K (black line) adjustment until the line by the first pass and the line by the second pass are in alignment.



Be sure to make adjustment for K first and then for other colors. Each color pattern has been set based on K. Therefore, if the K value is not correct, you can not make adjustments for color patterns correctly.

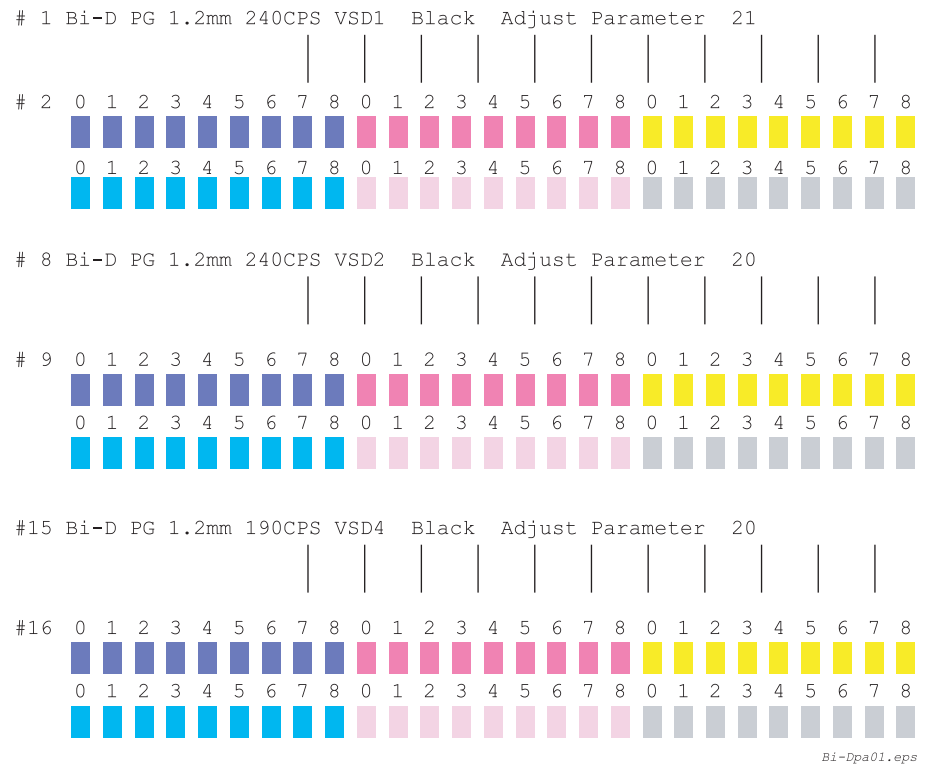

Figure 5-48. Bi-D Adjustment Patterns

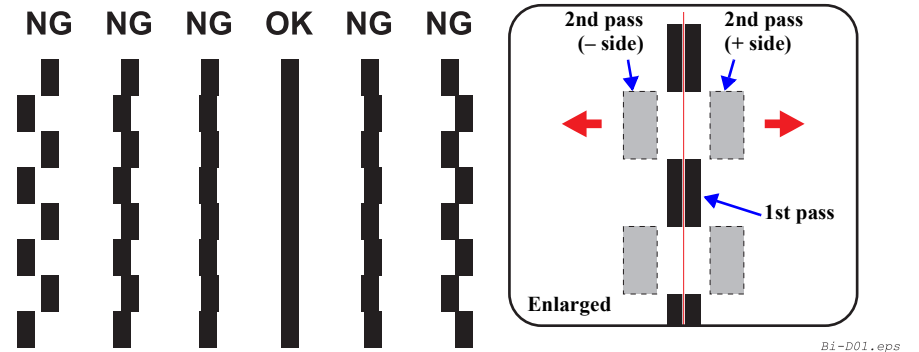
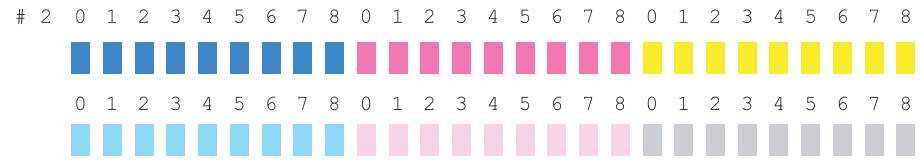
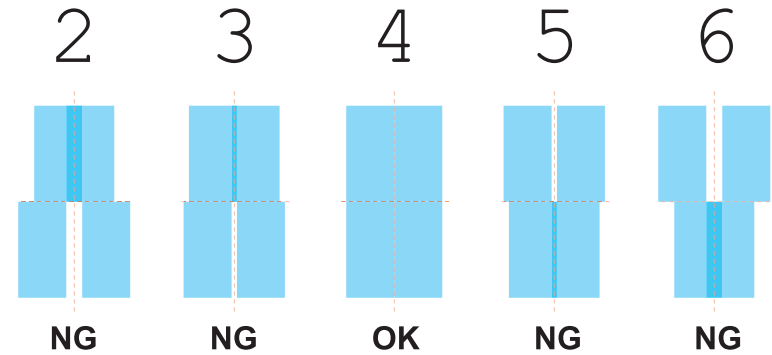

Figure 5-49. Round Trip Print Position (Bi-D) Adjustment (Black)

5. Print the 240, V1 color pattern:
Press [Enter ↵] when “240V1 COL PRN” is displayed. (See Figure 5-47)
6. Check the 240, V1 color pattern:
Of the 9 color blocks for each color, find out a pattern free from a gap or overlap and make certain that the number on the LCD is identical with the number shown above the pattern.
If the number on the LCD is different, input the pattern number.
7. Upon completion of the 240 V1 adjustment, make the adjustments for 240 V2 and 190V4 the same way.



CHECK POINT After completion of the adjustments above, be sure to make the “Round Trip Print Position Adjustment (Bi-D Adjustment)” (p.248).



Bi-Dpa01.eps

Figure 5-50. Color Pattern for Bi-D Adjustment

5.2.3.14 Parameter Copying

In actual processing, at each point when the adjusted value is determined in “5.2.3.13 Round Trip Print Position Adjustment (Bi-D Adjustment)” (p.248), the compensation value obtained by computation is copied into each area. Actually, therefore, copy processing by this function is not required. (See Figure 5-51)

5.2.3.15 Bi-D2 Adjustment (PG=0.7mm)



When this adjustment is to be performed, use the following paper since setting must be made for PG=0.7mm.
Paper to be used: Authentic glossy paper
 (Example: Photo Glossy Paper #MCSRxxR2)

Make this adjustment, as required, after executing “5.2.3.13 Round Trip Print Position Adjustment (Bi-D Adjustment)” (p.248).

The adjustment procedure is the same as that for “5.2.3.13 Round Trip Print Position Adjustment (Bi-D Adjustment)” (p.248).

5.2.3.16 Bi-D3 Adjustment (PG=2.1mm)



When this adjustment is to be performed, use the following paper since setting must be made for PG=2.1mm.
Paper to be used: Authentic plain paper roll (PMSPxxR6)

Make this adjustment, as required, after executing “5.2.3.13 Round Trip Print Position Adjustment (Bi-D Adjustment)” (p.248).

The adjustment procedure is the same as that for “5.2.3.13 Round Trip Print Position Adjustment (Bi-D Adjustment)” (p.248).

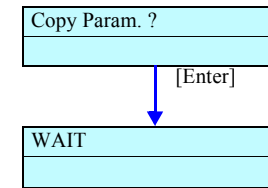

Figure 5-51. Menu Transition for Parameter Copying

5.2.3.17 Round Trip Print Position (Bi-D Adjustment) Checking

According to the result of the round trip print position adjustment, shift the pattern by the theoretically required number of dots. Then print the pattern and check the print result.

Check to see if the central patterns are in alignment and if not, perform the Bi-D adjustment again.

The menu transition for Bi-D adjustment checking and print patterns are shown at right.

NOTE: Figure 5-53 shows the print patterns for PG1.2mm. The patterns for PG0.7mm and PG2.1mm will also be printed.

- Pattern drawing method: #1, #2 360dpi, Bi-D, 240CPS, VSD1, Large
 #8, #9 360dpi, Bi-D, 240CPS, VSD2, Large
 #15, #16 360dpi, Bi-D, 190CPS, VSD4, Large

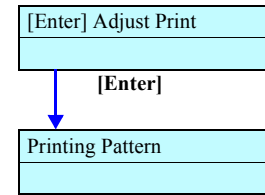

Figure 5-52. Menu Transition for Bi-D Adjustment Checking

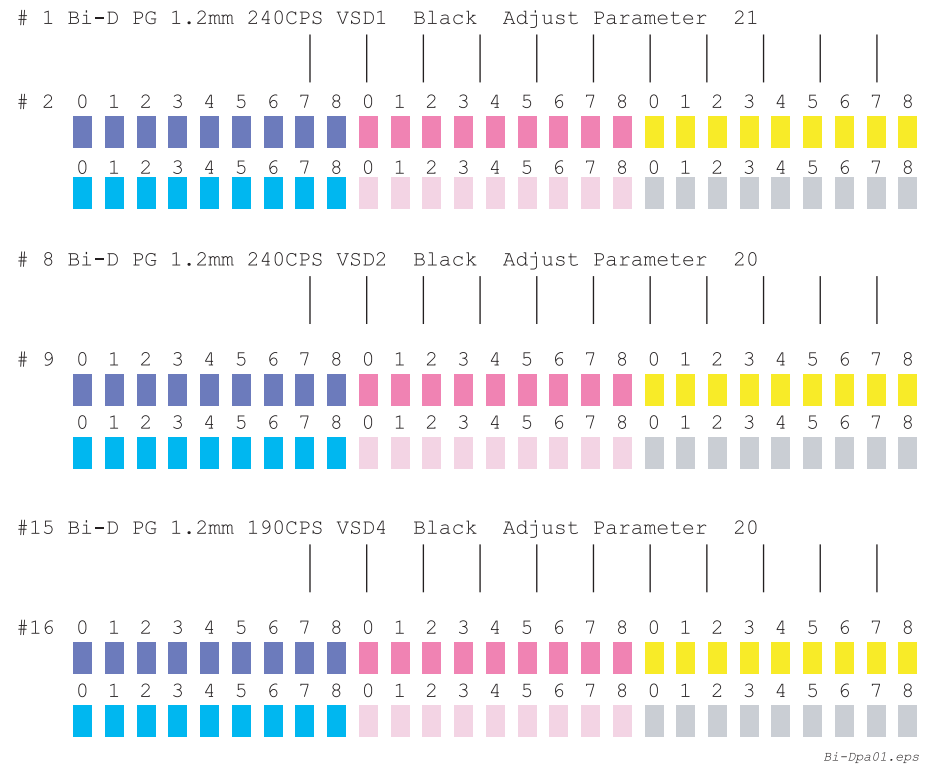

Figure 5-53. Print Patterns for Bi-D Adjustment Checking

5.2.3.18 Head Gap Adjustment (Uni-D Adjustment)

Correct the print position for one-way printing.

Make adjustments of “240CPS VSD1”, “240CPS VSD2” and “190CPS VSD4” for each color.

Store the adjustment values for each line of nozzles (18 kinds of values) in the Flash ROM.

For adjustment, conduct Uni-D printing and from the print results, input the compensation value.

The menu transition for Uni-D adjustment and print patterns are shown below.

Table 5-23. Head Gap Adjustment Items

Item	Contents
Gap 240,V1	Uni-D Adjustment 240CPS VSD1
Gap 240,V2	Uni-D Adjustment 240CPS VSD2
Gap 190,V4	Uni-D Adjustment 190CPS VSD4

- Adjustment resolution: 8.8 μm
- Adjustable range: ± 62 step adjustment possible
- Pattern drawing method:
 - 360dpi, Uni-D, 240CPS, VSD1, Large (240V1 selected)
 - 360dpi, Uni-D, 240CPS, VSD2, Large (240V2 selected)
 - 360dpi, Uni-D, 190CPS, VSD4, Large (190V4 selected)
- Press the [Enter] key after inputting the adjusted values and pattern number, and the pattern will be printed only when updated values have been input. When the values have not been updated, the display will change to the next input screen.
- When the [Enter] key is pressed with “Gap End” displayed, the display changes to “Adj: Feed Adj.+T&B”.



The adjustment is not required for any of #1, #8 and #15, which are black lines.

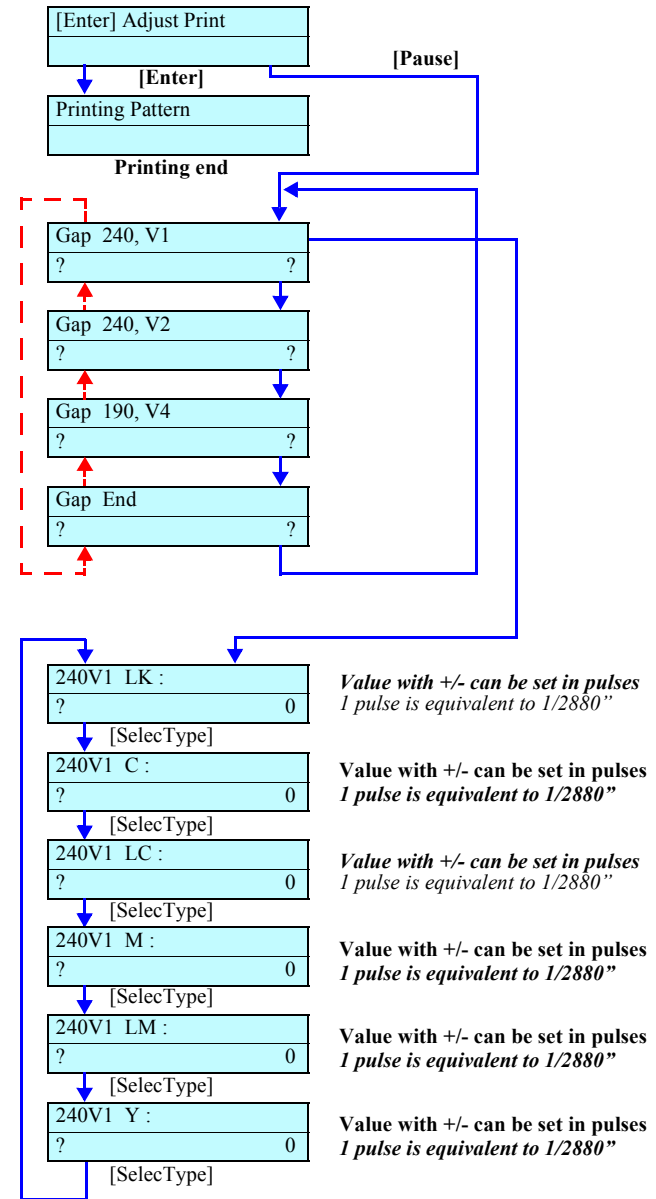

Figure 5-54. Menu Transition for Uni-D Adjustment

PROCEDURE FOR HEAD GAP ADJUSTMENT (UNI-D ADJUSTMENT)

1. Start the Self-diagnostic Function:
Power OFF → [Paper Feed Δ]+[Paper Feed ∇]+[Cut/Eject] → Power ON
 2. Display “Adj: Uni-D”:
[Paper Feed ∇] → [SelcType >] → [Paper Feed ∇] x11
 3. Print the pattern.
[SelcType >] → [Enter ↵] when “[Enter] Adjust Print” is displayed
(See Figure 5-55)
 4. Check the pattern:
Make certain that the black lines and color lines are not out of alignment.
When they are not out of alignment, leave the head gap adjustment mode by pressing [SelcType >] two times. If they are out of alignment, follow the instructions given below:
- If out of alignment**
1. Select the gap item in question:
Select “Gap 240,V1”, “Gap 240,V2” or “Gap 190,V4” by means of [Paper Feed ∇] and enter the adjustment menu for the selected item by pressing [SelcType >].
 2. Adjust the color position in question:
Select the relevant color by means of [SelcType >], and in consideration of the printed pattern, input the compensation value on the panel.
Shift direction (black line as reference):
(Compensation setting: in increments of 1/2880 inch)
Shift to the right = Input a (+) value
Shift to the left = Input a (-) value
 3. Check again:
Check the pattern output again, and when the lines are in alignment, leave the head gap adjustment mode by pressing [SelcType >] two times. If the lines are out of alignment, repeat inputting a value.

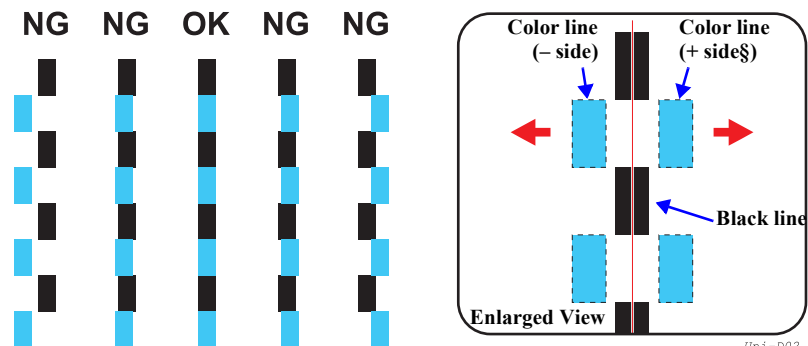
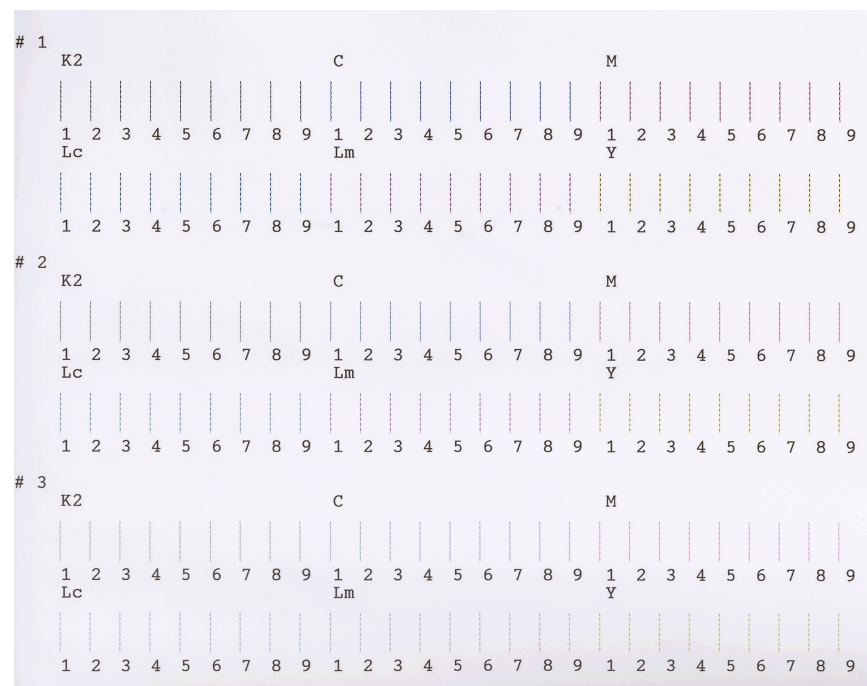

Figure 5-55. Print Pattern (Head Gap Adjustment)

CHECK POINT
Even when you have left the head gap adjustment menu, you can display the menu for an relevant item by means of [SelcType >]. Therefore, there is no need of outputting the comprehensive patterns again.

5.2.3.19 Test Pattern Printing

You can print adjustment patterns and check each adjustment item.

(See Figure 5-56)

- Check Ptn.:
Prints all the adjustment patterns (including the adjustment variables list)
(Time required: about 20 minutes)
- Check Ptn. 2:
Of the patterns to be output by “Check Ptn.”, the first pattern to the head gap adjustment (Uni-D) pattern will be output.
(Time required: about 5 minutes)
- Check Ptn. 3:
Of the patterns to be output by “Check Ptn.”, the Bi-D adjustment pattern to the adjustment variables will be output.
(Time required: about 15 minutes)

Adj. Variable:

Outputs the list of the setting compensation values (variables) determined by various adjustments.

- Press the [Cleaning] key on a serial number input screen, and the display will change to the next screen.
(For example, from “No.1: PEG**000000”, the display changes to “No.1: PEG**000000”.)
- Press the [Cleaning] key on the “Print Adj.Pattern” screen, and the display will change to the serial number input screen “No.1: PEG**000000”.

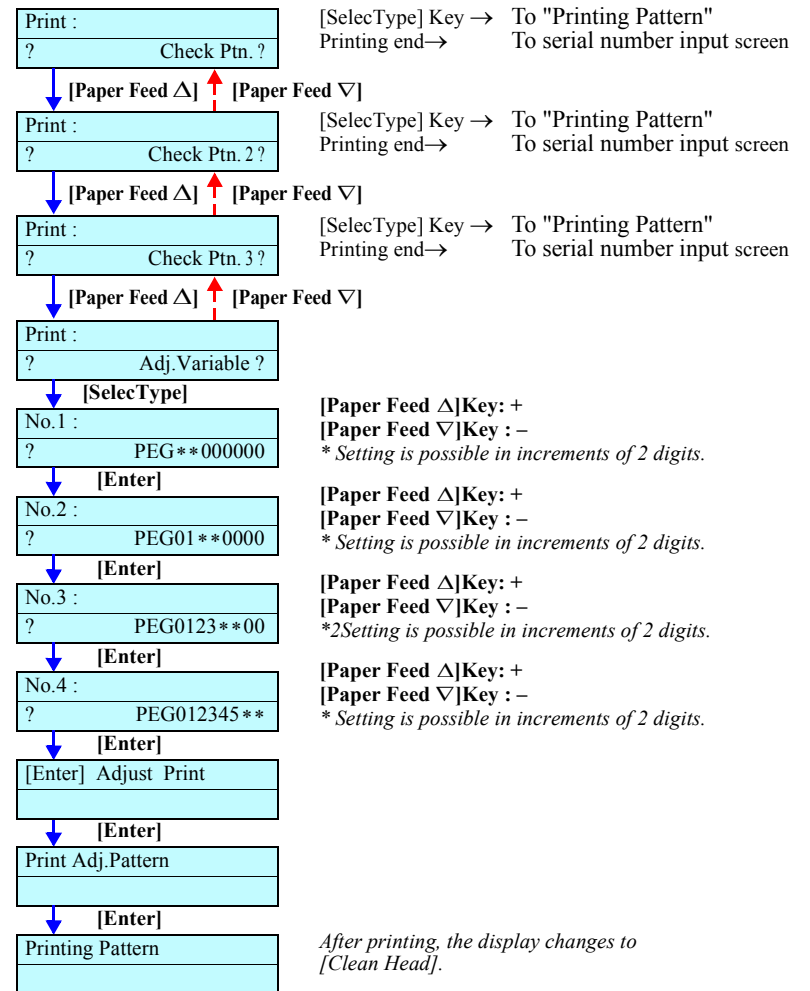



Figure 5-56. Menu Transition for Test Pattern Printing

5.2.3.20 Clean Head

When Head replacement is required on the service site, execute ink discharge (“*Ink Blowing*”) in this mode beforehand.

CHECK POINT  If transition in the sequence can not take place for some reason, the display shows “Reset ** I/C”.

When replacing the print head, execute ink discharge (“*Ink Blowing*”) by using this function.

CHECK POINT  ■ Prepare seven draining cartridges, which are necessary for this work.
 ■ “Opener I/C” in the menu display must be understood as “Draining Cartridge”.

- Procedure:
 In the flow as shown at right, upon completion of the first step for ink discharge, enter the branch for “Head Wash Skip” and “[Enter] End” to skip the other operations.

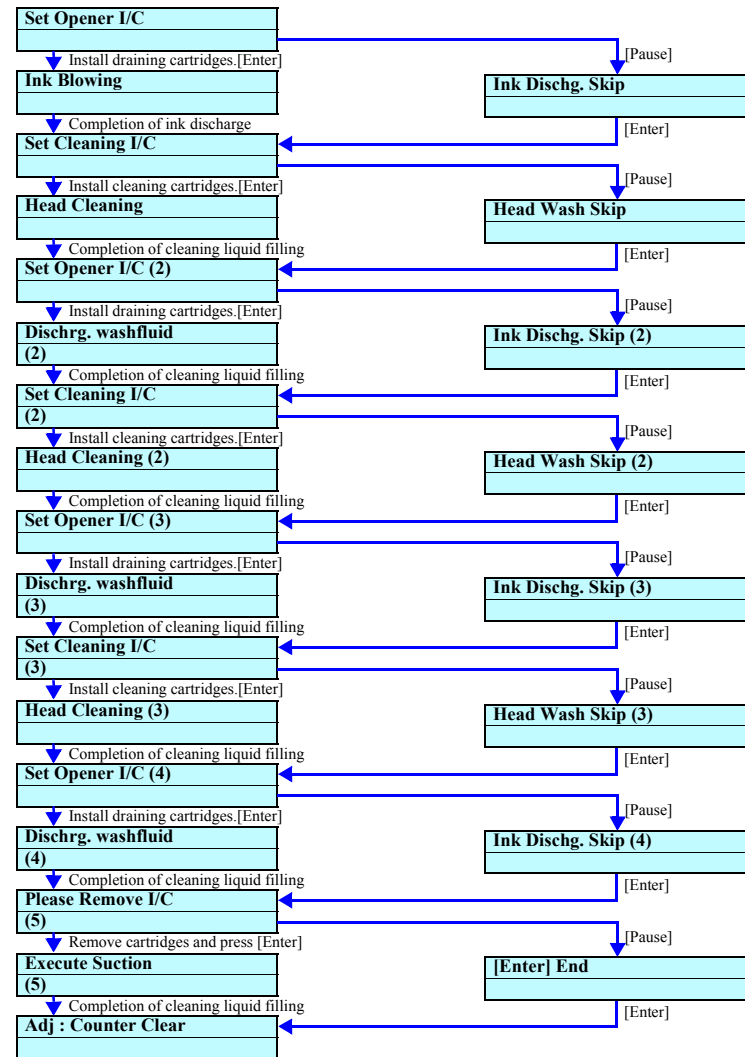

Figure 5-57. Menu Transition for Head Cleaning

5.2.3.21 Counter Clear



This function is to be used to initialize each counter value at the factory before shipment. Never use this function on the service site. (If you operate, all the counter values concerning ink system control will be lost and no operation or control after that will be carried out correctly.)

[Description below is given only for information]

Table 5-24 indicates the counters to be cleared and their initial values and Figure 5-58 shows menu transition for counter clearing.

Table 5-24. Counters to be Cleared and Their Initial Values

Counters to be Cleared	Initial Value
Protection Counter A	0
Protection Counter A Work	0
Protection Counter D	0
Protection Counter D Work	0
Protection Counter B	0
Protection Counter B Work	0
Ink Volume Counter Rb	0
Ink Volume Counter Rx	0
Ink Volume Counter Rz	0
Consumed Ink Counter K	0
Consumed Ink Counter LK	0
Consumed Ink Counter C	0
Consumed Ink Counter M	0
Consumed Ink Counter LC	0
Consumed Ink Counter LM	0
Consumed Ink Counter Y	0
CL1 Cumulative Counter	0
CL2 Cumulative Counter	0
CL3 Cumulative Counter	0
HP and Other Cumulative Counters	0
Timer CL Cumulative Counter	0
Yellow Shot Counter 1	0
Yellow Shot Counter 2	0
Accumulated Prints Timer	0
Timer for Timer CL Execution 1	0
Timer for Timer CL Execution 2	0
CL Flag	0 (Not during CL)
Initial Charge Counter	1 (Not completed)
Periodic Pseudo-Vacuum Flag	(0)

Table 5-24. Counters to be Cleared and Their Initial Values (continued)

Counters to be Cleared	Initial Value
Ink Type	0 (Neutral)
Ink OUT Judge Counter	(0)
Vacuum Compensation Coefficient	(90)
Discharge Compensation Coefficient	(90)
Compensation Permission Flag H	(0)
Cartridge Midway Replacement Flag	1 (Replaced)
CSIC Storage Area for Printer Body	FFh
Cumulative Ink Consumption	0
Cumulative Paper Consumption	0
Ink Consumption during Nozzle Check	0
Paper Consumption during Nozzle Check	0
Counters to be Cleared	0
Y Ink Cumulative Discharge Counter	0
Previous Y Ink Cumulative Discharge Counter	0
Y Ink Cumulative Discharge at Previous Ultrasonic Cleaning	(0)
Y Ink Cumulative Discharge at Previous Periodic CL2 Execution	(0)
CSIC Control Flag	1 (All valid)
Maintenance Menu Ink Related Count 1	1 for date 0 for others
Timer Initial Charge Execution Count	(0)
Initial Charge Previous Execution time	(0)
Timer Initial Charge Flag	(0)
Maintenance tank ink consumption (CSIC)	0
Head hot error flag	0 (Not error)
Borderless ink counter	0
Timer CL4 cumulative counter	0
Pump counter P	0
Maintenance tank detection	1 (ON)
CL5 cumulative counter	0
CL1 count with cleaning prohibited (7 colors)	0
Timer CL4 flag	0 (Not being executed)
Time having elapsed since previous K ink replacement sequence	0xffffffff
CL4 cumulative counter	0
K ink counter for ink system processing	0
Ink replacement sequence counter	0
Ink type changed MB flag	0 (Not changed)
Previous count-down ratio	0 (%)
Initial charge executed MB flag	0 (Not executed)
Initial charge executed MB flag	0

Note : The numeric value in () represents the initial value in the area which firmware does not use.

- After counter clearing, turn off the power once and then turn it on again to start the printer in the normal mode. Then the display as shown in [Figure 5-59](#) will appear when the counter clearing has been executed successfully. (However, only when the covers are closed, the Paper Set Lever in the down position and the ink lever is in the up position)

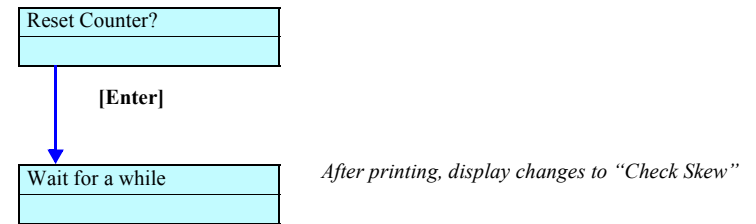

Figure 5-58. Menu Transition for Counter Clearing

SET INK	
CARTRIDGE	*

Figure 5-59. Display after Counter Clearing

5.2.4 Cleaning

Execute head cleaning.

Table 5-25 lists cleaning items and Figure 5-60 shows cleaning menu transition.

Table 5-25. Cleaning Items

Item	Display	Contents
Normal cleaning cycle KK0	Cleaning: Std. KK0	Minimum vacuum
Normal cleaning cycle KK1	Cleaning: Std. KK1	Maximum vacuum
Normal cleaning cycle KK2	Cleaning: Std. KK2	Maximum vacuum (With rubbing)
Initial charge	Cleaning: Init. Fill	Initial filling



After replacing the Damper ASSY and/or ink tube, if ink charging is to be performed without replacing the print head, execute "Initial charge" in this menu.

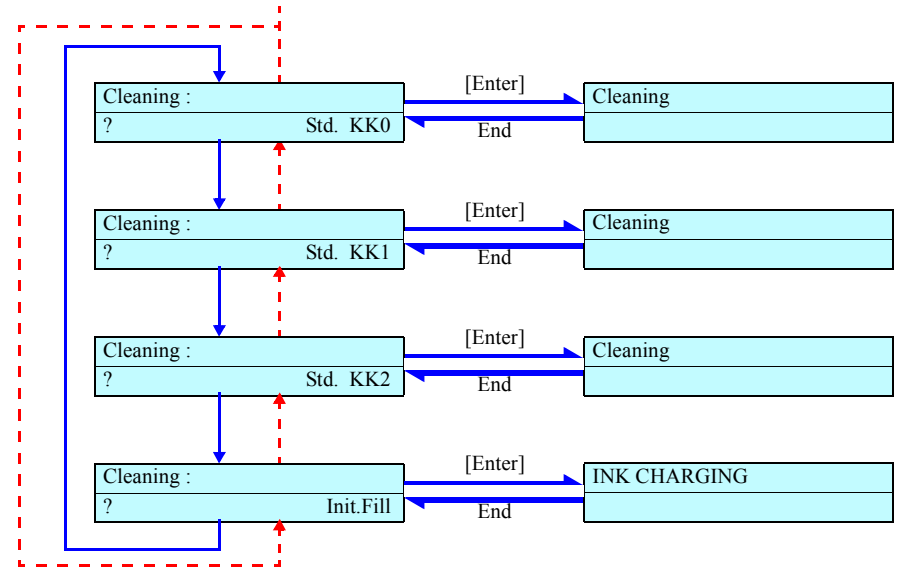

Figure 5-60. Cleaning Menu Transition

5.2.5 Print

Execute test pattern printing and/or adjustment variables printing.

Table 5-26 lists printing items and Figure 5-61 shows printing menu transition.

Table 5-26. Printing Items

Item	Display	Contents
Test Pattern	Print: Check Ptn.	Test pattern printing
Adjustment Variable	Print: Adj.Variable	Adjustment variables printing
Test Pattern 2	Print: Check Ptn.2	Test pattern printing
Test Pattern 3	Print: Check Ptn.3	Test pattern printing
Leak Check *	Print: Leak Check Ptn.	Air leak check pattern printing

Note "*": Once you have removed or replaced the Head, Damper, Ink Holder and/or Ink tube, execute this mode and make certain that there is no dot missing. If dot missing occurs, check the coupling screw tightening torque and tube insertion and check for air leak.

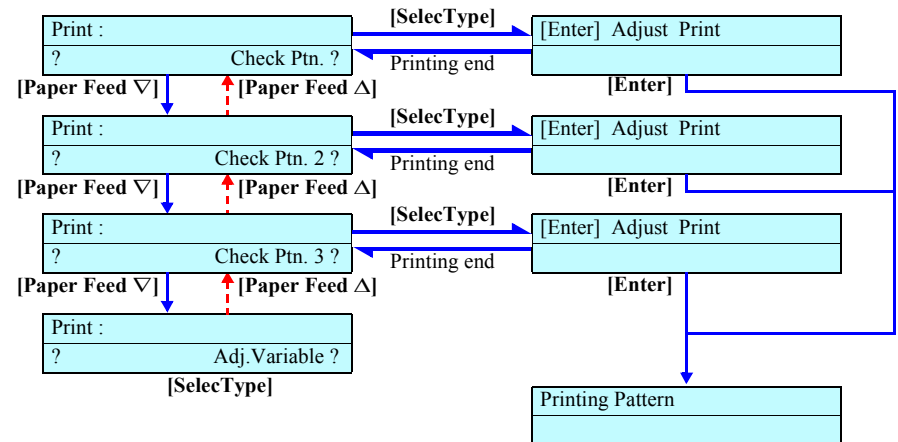

Figure 5-61. Printing Menu Transition

5.2.6 Parameter

This item relates to update of adjustment parameters.

Table 5-27 lists parameter items and Figure 5-62 shows parameter menu transition.

Table 5-27. Parameter Items

Item	Contents
Initialize	Initialize adjustment parameters
Update	Input adjustment parameter values
Display	Display adjustment parameter values

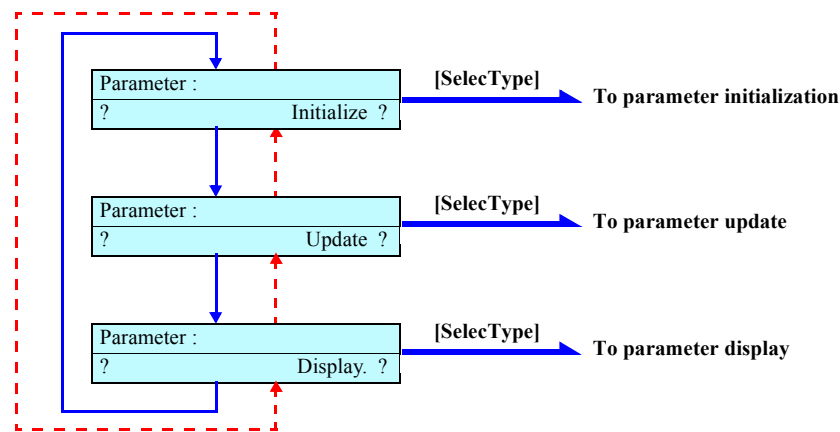

Figure 5-62. Parameter Menu Transition

5.2.6.1 Parameter Initialize

Execute parameter initialization.



Without replacing the relevant parts, never use this function to initialize the counter; otherwise, control after that will not agree with the condition of the printer mechanism.

Table 5-28.

Item	Contents
All initialization	CR motor round trip count
	PF motor travel
	Head ink discharge count (Each color)
	Cleaning count
	The number of printed sheets
	Ink volume counter
	Waste ink counter
	Cutting count
	Gap adjustment value
	CR origin compensation value (Capping position)
	PF origin compensation value
	Head slide origin compensation value
	Front sensor position compensation value
	Rear sensor position compensation value
	Edge sensor longitudinal position compensation value
	Edge sensor lateral position compensation value
	Cutter longitudinal position compensation value
	Flushing position
	PF distance correction 1 ~ 3
	Serial number
	Wiping count
	Rubbing count
	Ink tube round trip count
Paper presser lever up and down count	
Cover Open/Close count	
Ink lever up and down count	
Capping position initialization	CR origin compensation value (Capping position)
PF resolution initialization	PF distance correction 1 ~ 3
Serial number initialization	Serial number
Head record initialization	Head ink discharge count (Each color))
Wiper record initialization	Wiping count
Rubbing record initialization	Rubbing count

Table 5-28.

Item	Contents
Waste ink record initialization	Waste ink counter
CR motor record initialization	CR motor round trip count
PF motor record initialization	PF motor travel
Lever record initialization	Paper presser lever up and down count
Cover record initialization	Cover Open/Close count
Ink lever record initialization	Ink lever up and down count

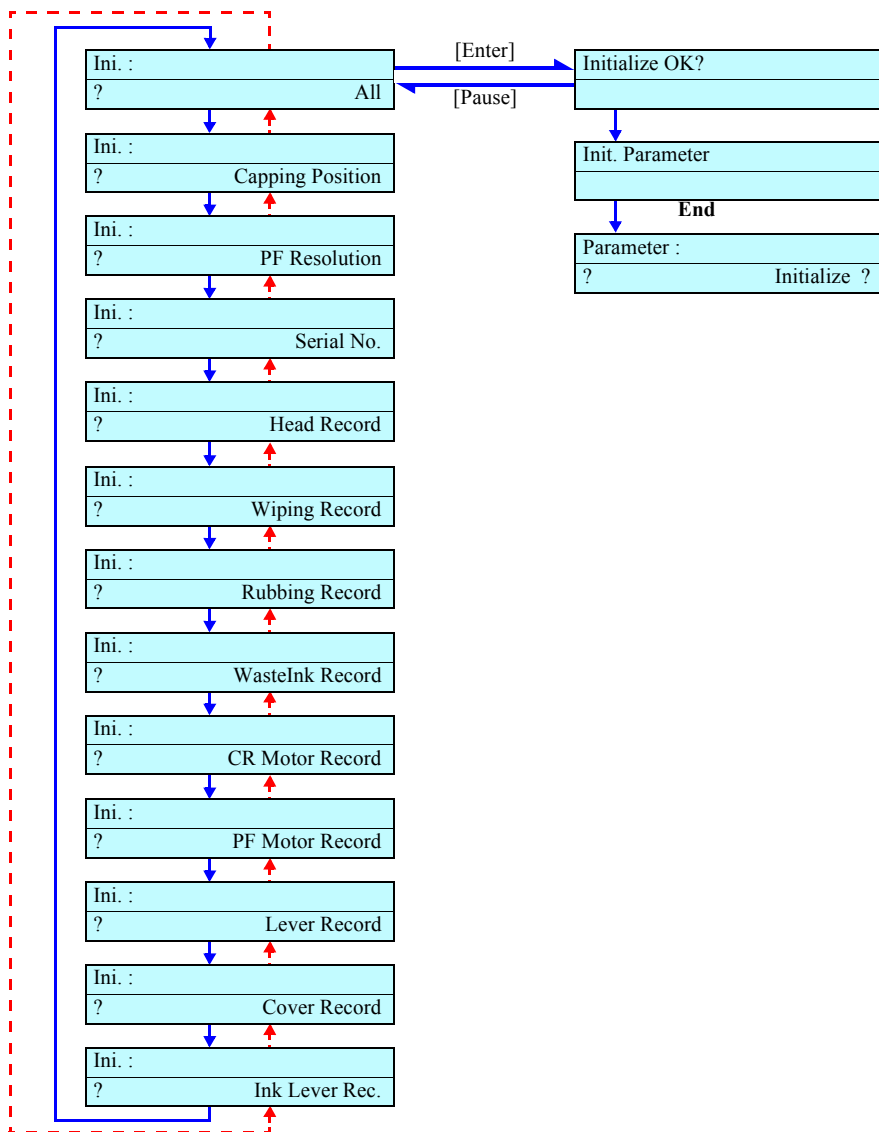

Figure 5-63. Menu Transition for Parameter Initialization

5.3 Mechanism Adjustment

5.3.1 Overview

This section describes the mechanism adjustments you need to perform when mechanical parts have been replaced or removed. The relationship between parts and required adjustments are as follows.

Table 5-29. Required Mechanism Adjustments

Item	Description	See
CR Timing Belt Tension Adjustment	At reinstallation of the CR Timing Belt, adjust its tension as specified.	p. 263
PF Timing Belt Tension Adjustment	At reinstallation of the PF Timing Belt, adjust its tension as specified.	p. 264
P_THICK_0.3/P_THICK Sensor Mounting Plate Position Adjustment	At reinstallation of the P_THICK sensor or P_THICK_0.3 sensor, make adjustment for paper thickness detection.	p. 265
Cover Sensor ASSY Mounting Position Adjustment	Adjust the mounting position of the Cover Sensor.	p. 267
CR Encoder Sensor Mounting Position Adjustment	Adjust the CR Encoder mounting position on the CR Unit, using the dedicated tool.	p. 268
Cutter Positioning Adjustment	Adjust the cutter position, using the dedicated tool.	p. 269
Paper Cutting Position Check	Check the result of the adjustment made above.	p. 271
Paper Cutting Position Check	Adjust the PF Encoder position, using the dedicated tool.	p. 272
Head Slant Adjustment (Mechanical Adjustment)	Adjust the Print Head slant using the self-diagnostic mode and by mechanical adjustment.	p. 247

5.3.2 CR Timing Belt Tension Adjustment

This adjustment is necessary for service operations that require you to remove/loosen the CR Motor or CR Steel Belt. When replacing or re-installing the CR Steel Belt, you need to confirm the tension of the CR Steel Belt. Tighten or loosen the screws on the Driven Pulley to increase or decrease the tension.

- No special tools are required.

NOTE: For details, refer to “CR Motor ASSY (p.180)”.

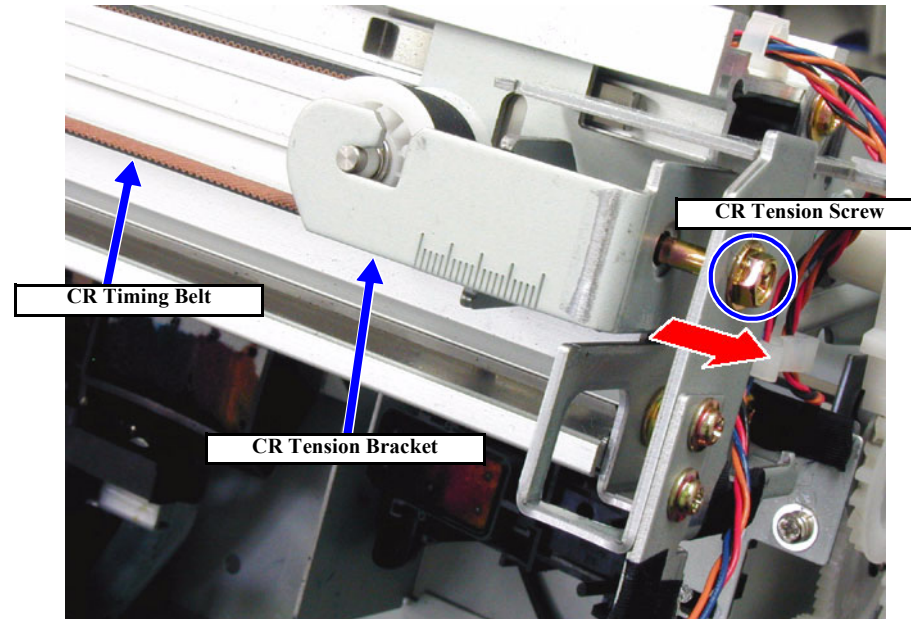

Figure 5-64. CR Timing Belt Tension Adjustment

5.3.3 PF Timing Belt Tension Adjustment

This adjustment is necessary for service operations that require you to remove/loosen the PF Motor or PF Belt. When replacing or re-installing the PF Belt, you need to confirm the tension of the PF Belt.

- Adjusting tools: Tension Gauge #F770
- Standard: 2,200g \pm 10%
(Tension in the PF motor mounting plate moving direction.)

NOTE: For disassembly and assembly procedure, refer to “PF Motor (p.185)”.

Loosen the screws (x4) fixed to the PF motor mounting board and set the tension gauge to the hole on the board and pull to the movable direction.

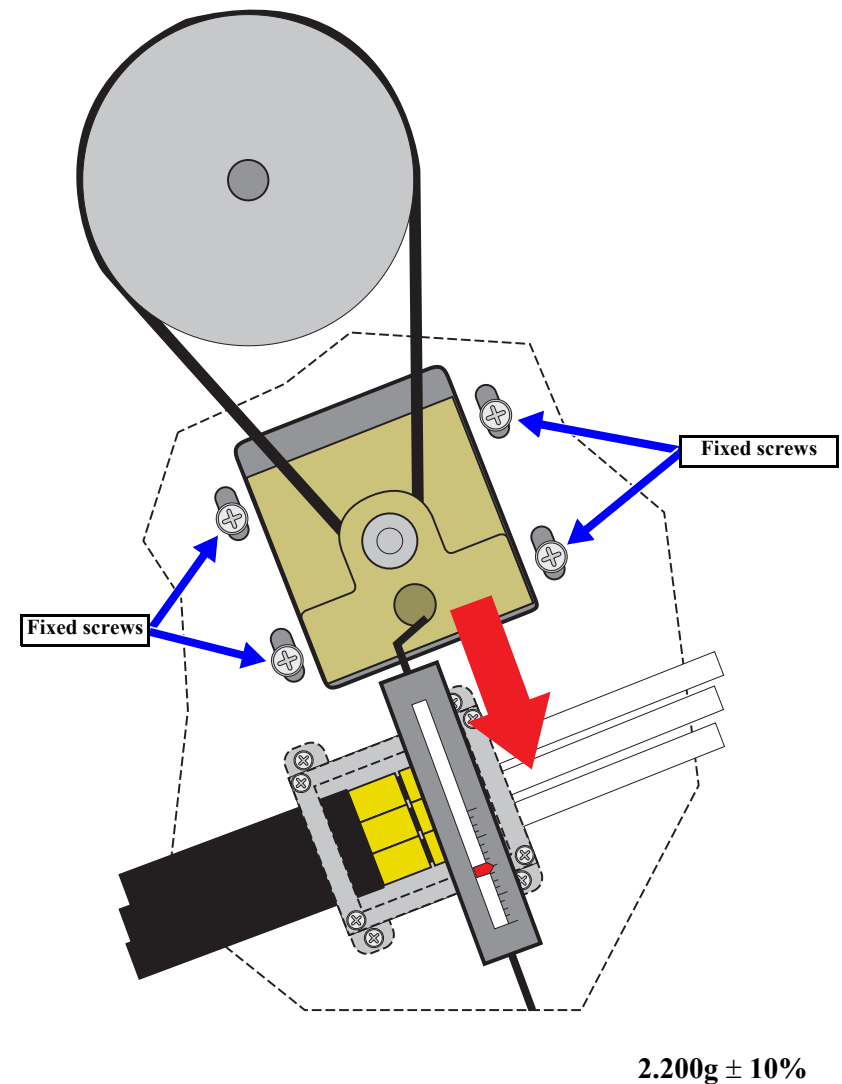

Figure 5-65. PF Belt Tension Adjustment

5.3.4 P_THICK_0.3/P_THICK Sensor Mounting Plate Position Adjustment

Once you have changed the position of the Sensor Mounting Plate on which the P_THICK_0.3/P_THICK Sensor is mounted, make the following adjustment using the self-diagnostic function.

- Adjusting tools: Thickness gauges (0.3, 0.4 / 0.8, 0.9mm)

NOTE: For disassembly and assembly procedure, refer to “P_THICK Sensor/ P_THICK Sensor_0.3 ASSY (p.190)”.

1. Remove the *H Top Cover*. (p.165)
2. Start the Self-diagnostic Function:
Power OFF → [Paper Feed Δ]+[Paper Feed ▽]+[Cut/Eject] → Power ON
3. Display “Test: Sensor”:
[SelectType >] → [Paper Feed ▽] x2
4. Display “Sen: Paper”:
[SelectType >] → [Paper Feed ▽] x2
5. Push down the Paper Set Lever rearward (to “release” position) and make certain that the value on the LCD changes to “10”.
6. Set the 0.4-mm thickness gauge between the PF Grid Roller and the Driven Roller near the detection arm on the paper transport path, and bring down the Paper Set Lever toward you (to the “paper holding” position). (See Figure 5-66)
At this point, if the value on the LCD is not “01”, loosen the screw securing the mounting plate for the P_THICK_0.3 Sensor (left). Then slide the mounting plate to a position where the LCD shows “01”, tighten the screw and remove the 0.4-mm thickness gauge.
7. Set the 0.3-mm thickness gauge the same way as above and make certain that the value on the LCD is “00”.
At this point, if the value on the LCD is not “00”, loosen the screw securing the mounting plate for the P_THICK_0.3 Sensor (left). Then slide the mounting plate to a position where the LCD shows “00”, tighten the screws and check the previous step again.

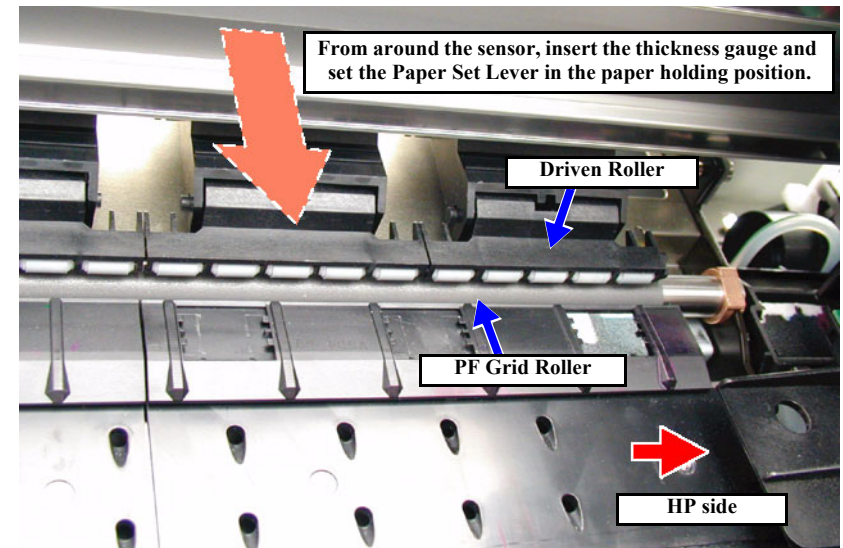

Figure 5-66. Gauge Setting Position

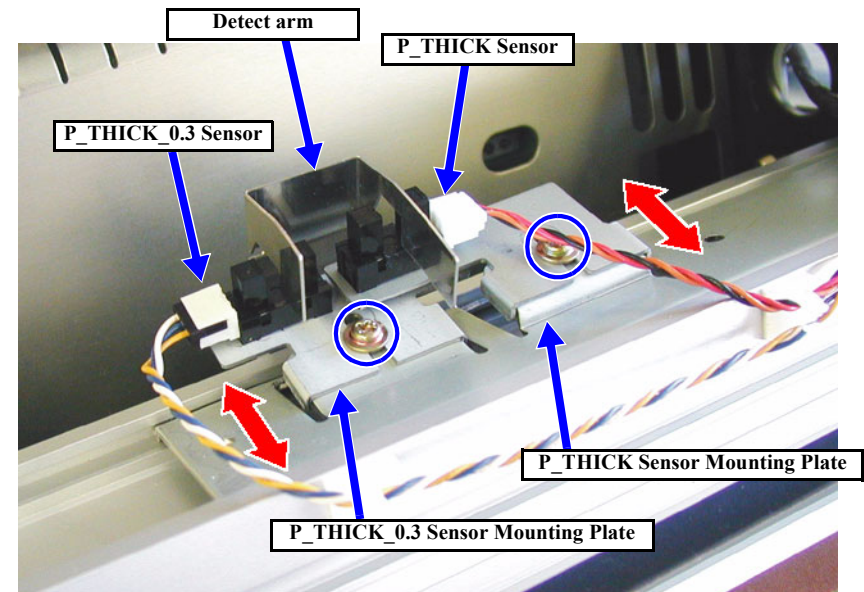

Figure 5-67. P_THICK Sensor / P_THICK_0.3 Sensor Position Adjustment

8. Set the 0.9-mm thickness gauge between the PF Grid Roller and the Driven Roller near the detection arm on the paper transport path, and bring down the Paper Set Lever toward you (to the “paper holding” position).
At this point, if the value on the LCD is not “11”, loosen the screw securing the mounting plate for the P_THICK Sensor (right). Then slide the mounting plate to a position where the LCD shows “11”, tighten the screw and remove the 0.9-mm thickness gauge.
9. Set the 0.8-mm thickness gauge the same way as above and make certain that the value on the LCD is “01”.
At this point, if the value on the LCD is not “01”, loosen the screw securing the mounting plate for the P_THICK Sensor (right). Then slide the mounting plate to a position where the LCD shows “01”, tighten the screw and check the previous step again.
10. Turn the power switch Off, then after disconnecting the power cable, install the H Top Cover.

Table 5-30.

Mounting Plate	Gauge	Condition	LCD Indication
P_THICK 0.3 Sensor Mounting Plate (left)	0.3 mm	Paper thickness 0.3 mm or below	00
	0.4 mm	Paper thickness 0.4 ~ 0.6 mm	01
P_THICK Sensor Mounting Plate (right)	0.8 mm	Paper thickness 0.7mm or above	11
	0.9 mm		
-		Lever in “Up” position (Paper released)	10
		Lever in “Down” position (Paper held)	00

CAUTION

Take care not to bend thickness gauges by, say, dropping.
This adjustment requires an accuracy to units of 0.1 mm.

5.3.5 Cover Sensor ASSY Mounting Position Adjustment

When removing/replacing the Cover Assembly or the Front Cover, verify the sensor operation using the Self-Diagnostic mode as described below.

NOTE: For disassembly and assembly procedure, refer to “Cover Sensor ASSY” (p.197).

1. Remove the Tube cover. See “Cover Sensor ASSY” (p.197).
2. Start the Self-diagnostic Function:
Power OFF → [Paper Feed Δ]+[Paper Feed ▽]+[Cut/Eject] → Power ON
3. Display “Test: Sensor”:
[SelectType >] → [Paper Feed ▽] x2
4. Display “Sen: Cover”:
[SelectType >] → [Paper Feed ▽] x1
5. Open and close the Front Cover, checking the LCD to make sure the message changes depending on the Front Cover position.

Table 5-31. Cover Sensor Assembly Check

Front Cover	LCD Message
Open	Sen: Cover Open
Close	Sen: Cover Close

6. If the correct message does not appear or any other message appears, verify the Cover Sensor is installed correctly and check the operation again.



Acceptance Criterion:
The timing for cover opening is such that there is no gap between the front cover and the printer body which permits entrance of your finger.

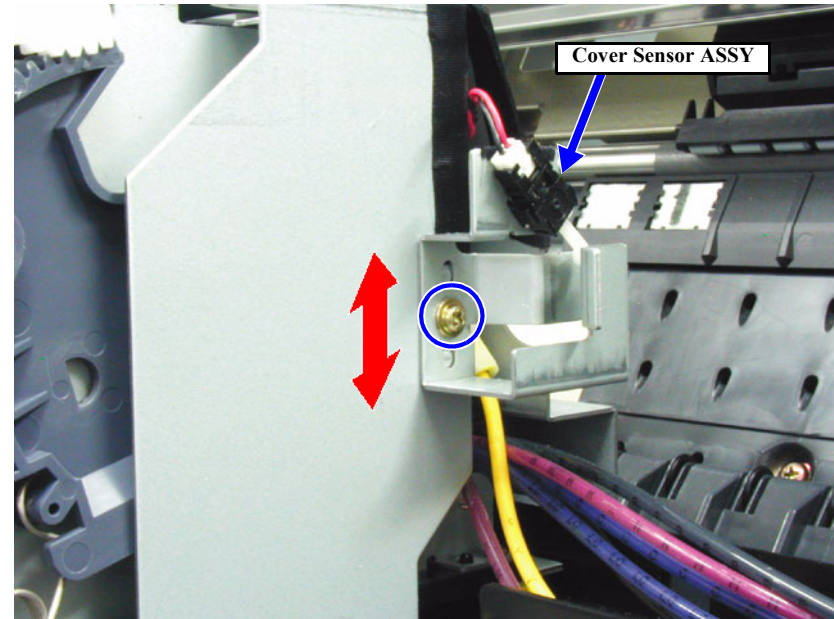

Figure 5-68. Adjusting the Cover Sensor ASSY Mounting Position

5.3.6 CR Encoder Sensor Mounting Position Adjustment

This adjustment should definitely be done when the CR encoder sensor is removed or replaced.

□ Adjusting tools: CR Encoder Sensor mounting jig #F799

NOTE: For disassembly and assembly procedure, refer to “CR Encoder Sensor ASSY (p.178)”.

1. Remove the *H Top Cover*. (p.165)
2. Remove the two screws securing the CR Board Unit in the Carriage Unit, and take out the CR Board Unit toward the front. (See *Figure 5-69*)
3. Move the Carriage Unit to the center by manual operation.
4. Loosen the screw securing the CR Encoder Sensor Board, and set the CR ENC Sensor positioning jig between the CR Encoder Sensor and the CR Guide Rail. (See *Figure 5-70*)
5. Push the CR Encoder Sensor to the exclusive tool side (CR Guide Rail side), then tighten the CR Encoder Sensor mounting screw securely.
6. Move the Carriage Unit to the right or left manually and recheck the mounting position of the CR Encoder Sensor. (Check at 3 positions)

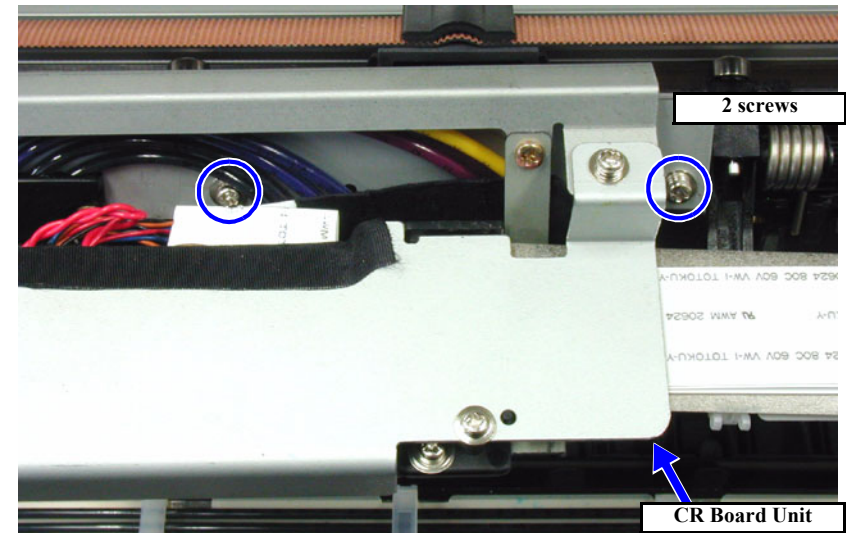

Figure 5-69. Adjusting the CR Encoder Sensor Mounting Position 1/2



In this adjustment, use the CR Encoder mounting jig for exclusive use with Stylus Pro 7600 / 9600: do not use the CR Encoder mounting jig designed for any other printer models.

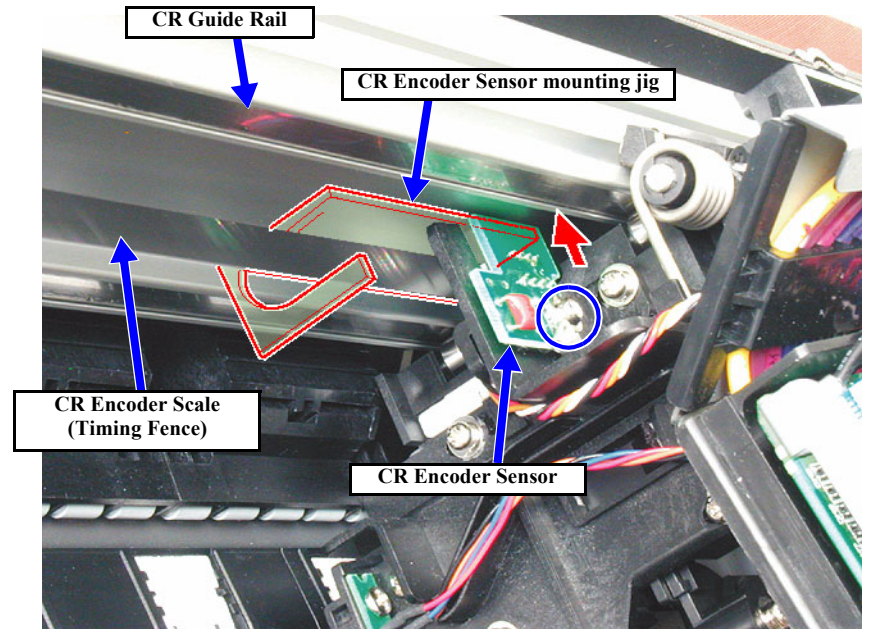
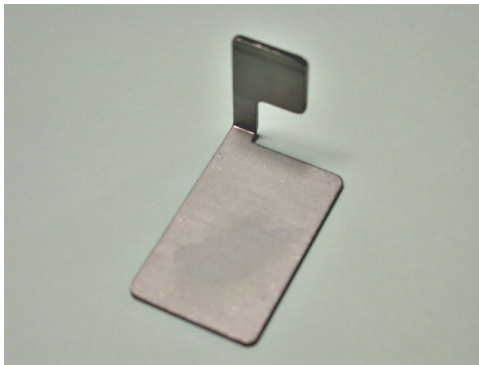

Figure 5-70. Adjusting the CR Encoder Sensor Mounting Position 2/2

5.3.7 Cutter Positioning Adjustment

This adjustment should definitely be made if the following parts are removed.

Parts	Adjustment Items
Cutter Solenoid Assy	1. Paper Guide L up and down adjustment 2. Cutter Holder ASSY height adjustment
Paper Guide L	1. Paper Guide L up and down adjustment

This adjustment is intended to install the cutter at a proper position and height relative to the step for the cutter on the Paper Guide L. The number of adjustment items required depends on the parts replaced. Carry out work by referring to the table above.

□ Adjusting tools: Cutter positioning jig #F800

NOTE: For disassembly and assembly procedure, refer to “Cutter Holder ASSY (p.175)”.



For adjustments at replacing the Cover Sensor ASSY, make the Paper Guide L up and down adjustment first and then make the Cutter Holder ASSY height adjustment.

1. Remove the *H Top Cover*. (p.165)
NOTE: For Stylus Pro 9600, remove also the *H Top Cover* (p.165) and the *Tube Cover* (p.193).
2. Open the Front Cover, and remove the cutter.
3. Return the CR Unit to the cap position and set the cutter positioning tool at the right end of the Paper Guide L. (See Figure 5-73)
4. Loosen the screws securing the Paper Guide L.

NOTE: 3 screws for Stylus Pro 7600 / 5 screws for Stylus Pro 9600



To loosen the screw at the left end of the Paper Guide L, pass the screwdriver through the cut portion of the I/H Frame Top Plate. (See Figure 5-72)

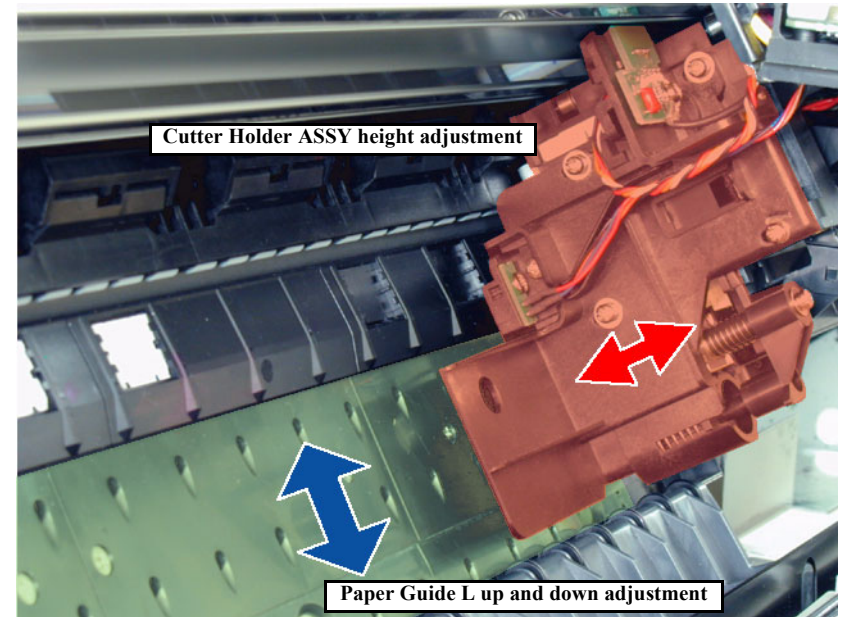

Figure 5-71. Cutter Positioning Adjustment

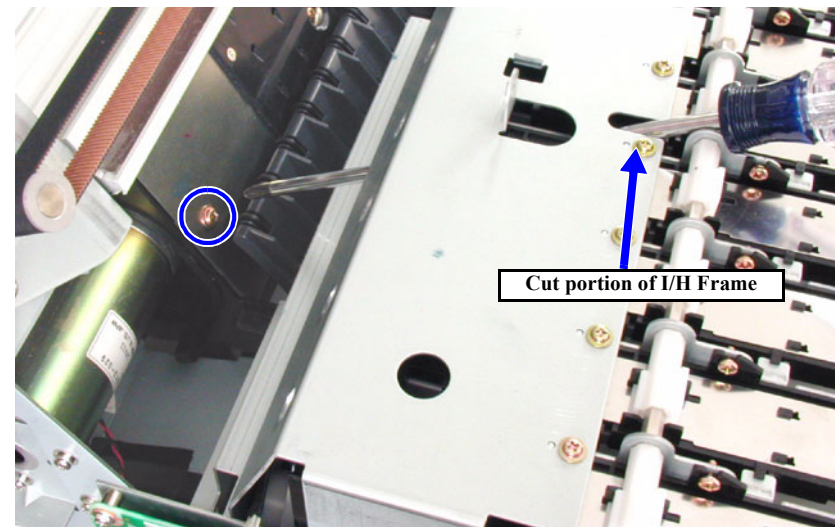
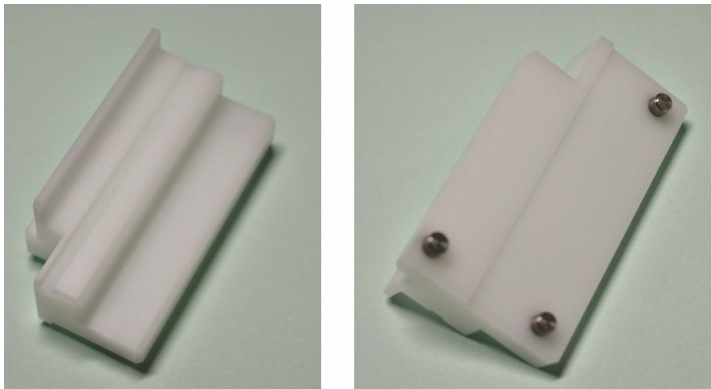

Figure 5-72. Removing the screw for Paper Guide L (at left end)

5. Slide the CR Unit onto the cutter positioning jig, shift the Paper Guide L up or down to a position where the plate of the Cutter Holder ASSY comes in contact with the projection in the lower part of the jig, and tighten the screw.
 - For replacement of Cutter Solenoid ASSY:
After completion of the Paper Guide L up and down adjustment, loosen the four screws securing the Cutter Holder ASSY to the CR Unit, press the front end of the Cutter Holder ASSY gently against the tool and tighten the four screws.
(See Figure 5-74)
6. Set the jig at the left end of the Paper Guide L and make the same adjustment and checking as step 4 ~ 5 above.
7. Move the carriage to around the center and make checking again.



■ In this adjustment, use the cutter positioning jig for exclusive use with Stylus Pro 7600 / 9600: do not use the cutter positioning jig designed for any other printer models.



- The positions where to set the jig for checking and adjustment should be the right and left ends as close to the frame as possible.
At any position where the Paper Guide L is not supported, the adjustment can not be made properly because of a deflection of the Paper Guide L.
- After successful completion of the adjustment above, proceed to the next item “Paper Cutting Position Check” (p.271).

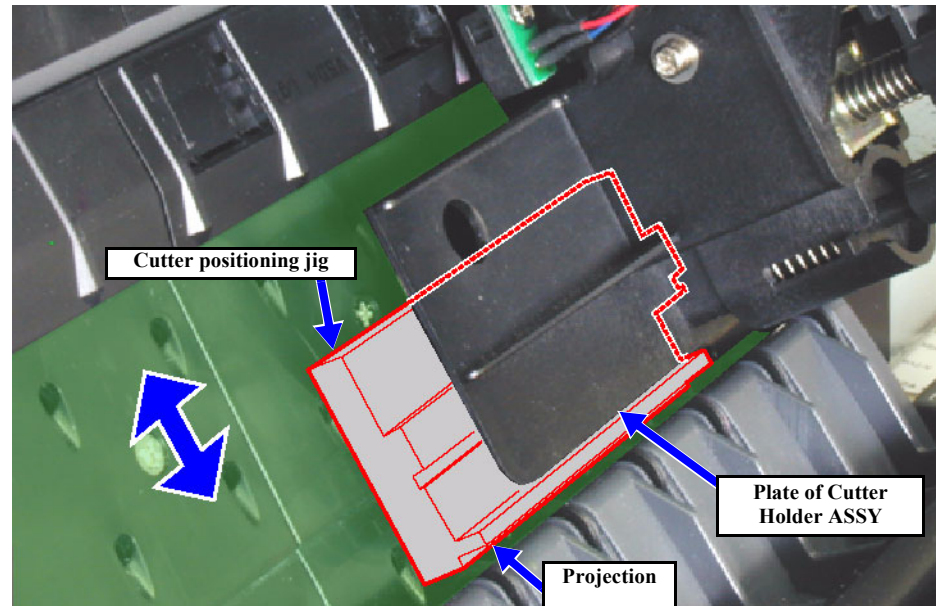

Figure 5-73. Paper Guide L up and down adjustment

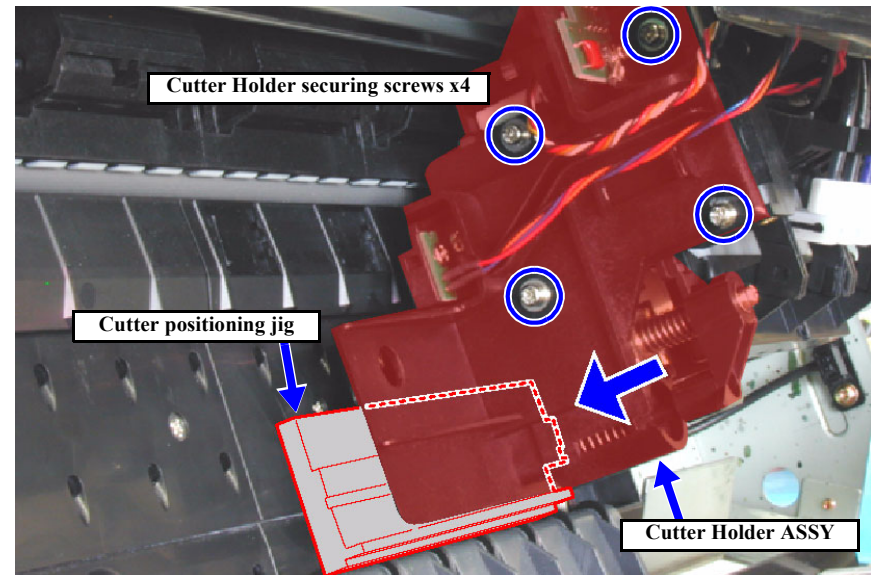

Figure 5-74. Cutter Holder ASSY height adjustment

5.3.7.1 Paper Cutting Position Check

Check the paper cutting position which has been adjusted as instructed in the previous section, by cutting paper actually.

□ Cutter Positioning Adjustment

1. Set paper (minimum size: about 10 cm wide x 20 cm) in the paper path along the paper setting position on the right side of the printer, then move the paper set lever to the front to hold the paper.
2. Move the CR manually to the right edge of the paper, then lower the cutter manually.
3. While holding the bottom edge of the paper with one hand, cut the paper with the cutter.
4. set a gauge with minimum measuring units of 0.5 mm at the edge of the cutter level difference on the sub-platen and check if the distance from the edge of the cutter level difference to the actual paper cutting position is within 0.5 mm (+0.1/-0.2mm).
5. If the measuring results are outside the standard, loosen the 3 screws holding the paper guide L, then carry out fine adjustment of the paper guide L's assembly position.

CHECK
POINT



- The length from the edge of the cutter level difference to the front edge of the paper where it was actually cut should be within 0.5 mm (+0.1/-0.2mm).
- If you are adjusting the assembly position of the paper guide L, the installation screws that are loosened should be the absolute minimum number of screws necessary to adjust the position. If a large number of screws is loosened, the assembly position of the paper guide L will shift a great distance from the original adjustment position, so caution should be exercised.

6. In the same way, set paper on the left side of the printer, cut the paper manually and measure the length from the cutter level difference to the front edge of the paper. If the measurement results are not within the standard, loosen about 3 of the screws holding the paper guide L and carry out fine adjustment of the paper guide L's assembly position.

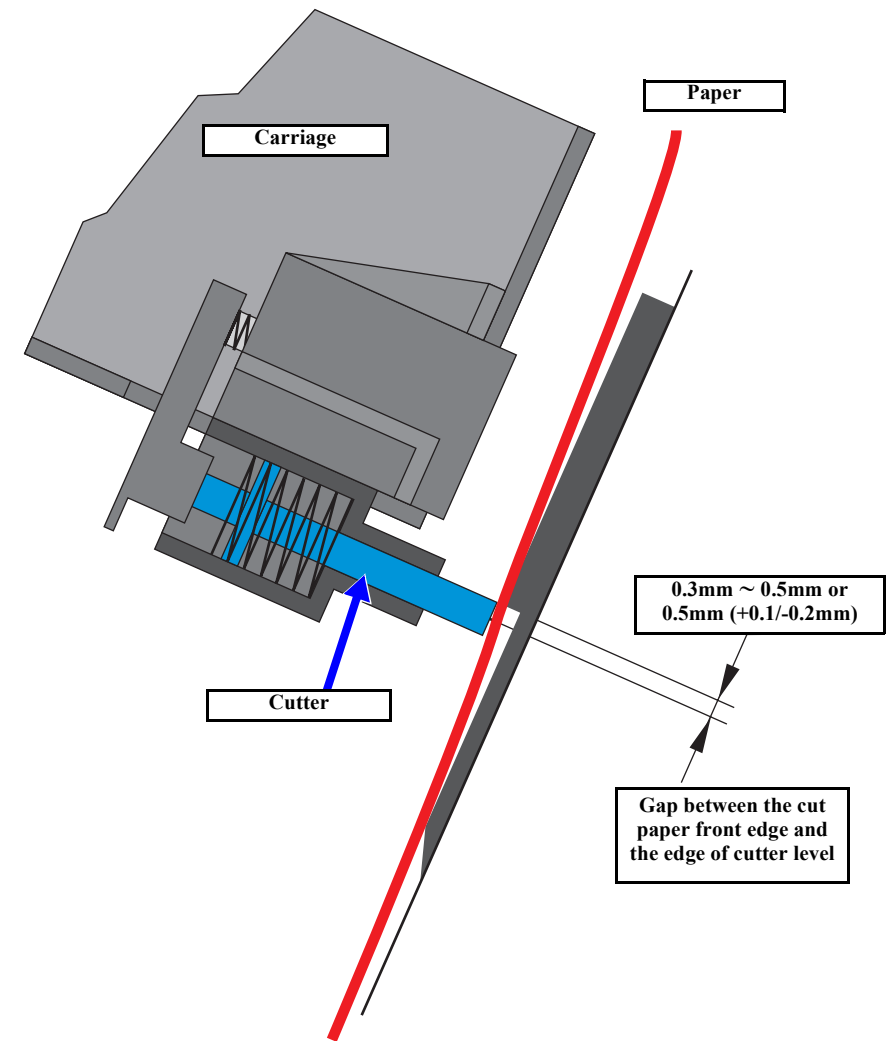

Cut_posi01.eps

Figure 5-75. Paper Cutting Position Check

5.3.8 PF Encoder Sensor Installation Position Adjustment

This adjustment is performed to set the distance between the PF roller shaft (grid roller) and PF encoder sensor in the proper position. Through this adjustment, the position of the PF encoder sensor's emitter and receptor are set properly with respect to the slits in the loop scale for the PF motor.

□ Adjusting tools: PF ENC Installation Position Adjustment Tool #F798

1. Loosen the one screw securing the PF Encoder Sensor, then put the round hole of the PF Encoder mounting jig on the PF Roller Shaft and fit the notched end against contour of the PF Encoder Sensor's emitter (outside).
2. Move the PF Encoder Sensor up and down so that it is in a position where the clearance between the contour of the PF Encoder Sensor and the notch in the PF Encoder mounting jig becomes uniform, then tighten the one screw securing the PF Encoder Sensor.

CHECK
POINT



In this adjustment, use the PF Encoder mounting jig for exclusive use with Stylus Pro 7600 / 9600: do not use the PF Encoder mounting jig designed for any other printer models.

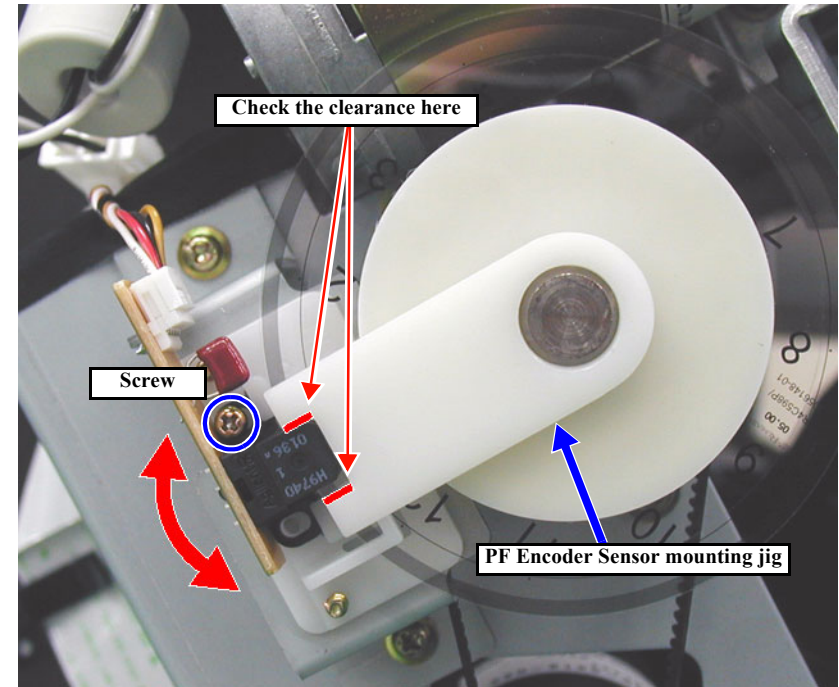
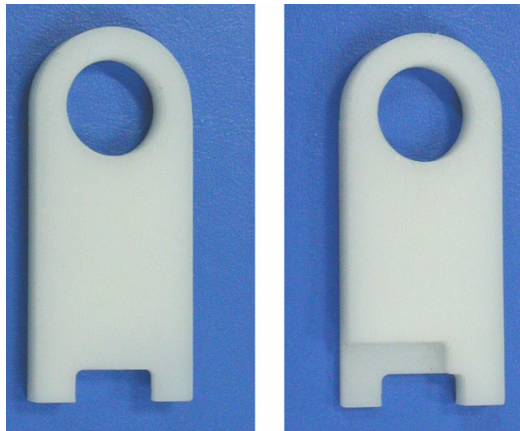

Figure 5-76. PF Encoder Sensor Installation Position Adjustment

5.3.9 USB ID Writing

**CHECK
POINT**

Even when you have replaced the Main Board, there is no need of new setting of the USB ID, since the USB ID is backed up if parameter backup can be executed.
When new setting is to be performed, use the dedicated service utility.

CHAPTER

6

MAINTENANCE

6.1 Overview

This section explains necessary maintenance items and their details for this product. Basically for this product, service technicians are required to visit the user's location where the EPSON Stylus Pro 7600/9600 is used, and perform necessary maintenance/service on-site while following the precautions below. Service technicians have to be extra careful not to cause any accident to the product or the user's environment.



- Since the power switch is mounted on the secondary circuit of the power supply circuit, unless otherwise specified, always turn off the printer using the power switch. After all moving parts have stopped, wait several seconds and then disconnect the power cable from the AC plug socket to prevent electric shock or circuit damage during service operations.
- The cover open sensor for detecting the open/close condition of the front cover has an interlock switch that functions as a safety device. Therefore, it is prohibited to turn off this switch.
- A lithium battery is installed on the MAIN Board of this printer. Be sure to observe the following instructions when servicing the battery:
 - Keep the battery away from any metal.
 - Do not install the battery in the wrong direction. (This may cause burning or explosion.)
 - Do not heat the battery or put it near fire.
 - Do not set the C472 MAIN board directly on top of any object which is conductive.
- Be careful not to let ink get into your eyes or your skin. If ink gets in your eye, rinse them immediately with water.



- When performing service and maintenance operations, sufficient space should be assured surrounding the place where the work is performed.
- The printer should be set in a place where there is no vibration, and where it is level and stable.
- This machine is extremely heavy, so adequate caution should be exercised when handling it. (If you are taking or reinstalling the body and stand, there should be 2 or more persons doing the work.)
- If operations are performed which involve the removal of ink system parts, there is danger of the product or the floor, etc. in the place where it is installed becoming soiled, so sheets, etc. should be spread on the floor, etc. during the work of removing parts related to the ink channels.
- If you are handling electrical circuit boards, to prevent destruction of the elements by static electricity, the elements on the board should not be touched with bare hands. If necessary, take the necessary measures to prevent static discharge, such as wearing a ground strap, when performing such work.
- If you are removing the various covers and operating the printer in that state, adequate caution should be used so as not to be injured by high speed operating parts such as the PS fan.
- The cutter blade is extremely sharp, care should be taken not to be injured by it.
- The an ultra-hardened blade is used for the cutter blade, and materially, this item is extremely brittle, so it should not be bumped against any metal or other parts on the printer when handled.
- If the printer that has already been installed needs to be packed and transported again, first make certain that the print head has been capped properly with the power to the printer turned off. Then remove all the ink cartridges and install all the packing materials as referred to in the Start-Up Guide or Assembly and Setup Guide supplied with the printer.

6.1.1 Periodic Maintenance Items and Product Life Information

Periodic Maintenance Items

The printer uses sensors and counters to determine when consumable items need to be replaced. When a consumable part has reached its predetermined end-of-life according to the corresponding counter, a message appears. See Table 6-1 for parts which require periodic replacement.

Product Life Information

Table 6-1 shows the product life about the printer body, each mechanism and various parts. Information regarding to the product life can be checked by the following way.

Panel Setting: “Printer Status Menu”

The amount of ink remaining is indicated on the LCD. (“F*****E” - F = full, E = empty, and each asterisk * represents a percentage of the total ink.)

Also, the counters which record these values can be initialized by “Maintenance Mode 2”.

CAUTION

Do not perform the counter initialization without replacing the corresponding parts and checking their operation. Since the counters for “Waste Ink Life” and “Ink Remaining Quantity” influence printer operations, do not clear them unnecessarily.

Table 6-1. Stylus Pro 7600/9600 - Lives of Periodically Replaced Components and Maintenance

Print Volume (# of sheet)	Product Life (Specification)	Cutter		Maintenance Tank		Cleaning Unit		CR Motor		PF Motor		Print Head	
		SPro7600/9600	SPro7600	SPro9600	SPro7600	SPro9600	SPro7600	SPro9600	SPro7600	SPro9600	SPro7600	SPro9600	SPro7600
1000 pages		Film media*7											
2000 pages		Coated paper*7											
5000 pages			5000p*1										
10000 pages					8000p*1								
				11000p*2									
20000 pages	SPro9600							20000p					
								2.5Million passes*3					
50000 pages	SPro7600							50000p					
								3.25Million passes*4		*5			28 Billion shots/nozzle

Warning message	-	MAINTENANCE TANK ALMOST FULL	-	-	-	-	-	-	-	-
Error message	-	MAINTENANCE TANK FULL *6	-	-	-	-	-	-	-	-
MAINTENANCE REQ	nnnn	-	-	0040	0002	-	-	0020	-	-
SERVICE REQ	nnnnnnnn	-	-	-	0000101	-	-	-	-	-

Reset operation	(Counter cleared automatically by replacing it with new one)	◆Counter clear MM2: CLEAR COUNTERS CLEANER	◆Counter clear MM2: CLEAR COUNTERS CR MOTOR	◆Counter clear MM2: CLEAR COUNTERS PF MOTOR	◆Counter clear MM2: CLEAR COUNTERS HEAD
Parts to be replaced	Paper cutter (CRU)	Maintenance Tank (CRU)	1. Pump&Cap Assy 2. Flushing Box 3. Wiper	At first SR: (& check Ink tubes/ FFC conditions) 1. CR Motor 2. Driven Pulley At second SR: 1. CR Motor 2. Driven Pulley 3. Ink tubes 4. FFC	*(as required) • Check the condition of loop scale (worn, etc.) • Check the condition of PF Encoder (foreign matters or dust)
Required adjustments	(Not required)	(Not required)	(Not required)	1. CR Belt Tension ADJ 2. Adj: Bi-D 3. Adj: Uni-D 4. Adj: Sponge Pos.	1. PF Belt Tension ADJ 2. Adj: Feed Adj.+T&B 1. Adj: Input Rank 2. INK CHARGING 3. Adj: Head Slant 4. Adj: Feed Adj.+T&B 5. Adj: Sponge Pos. 6. Adj: Bi-D 7. Adj: Uni-D

Note : In the table above, the values by white characters with black background represent the specified lives and the values by italic characters with bold frame represent standard lives (can vary with the conditions under which the printer is actually used).

Note "*1": Continuous printing with "Plain paper / Speed" mode on B0 size paper.

"*2": Continuous printing with "Plain paper / Speed" mode on A1 size paper.

"*3": Print in 360x360/MF/Bi-D mode on B0 paper.

"*4": Print in 360x360/MF/Bi-D mode on A1 paper.

"*5": The life of PF motor is counted based on the paper feeding distance at printing operation (23000 m).

"*6": Error condition and the printer is not ready to print until the error is cleared by replacing the maintenance tank to new one.

"*7": EPSON standard media and the cutting operation is made in "3 steps cutting" mode.

6.1.2 Important Maintenance Items During Service Operations

Check the following items during printer maintenance/service and perform any necessary operations.

Table 6-2. Items to be Checked During Maintenance/Service

Items	Check Points	Remedy
Lower Paper Guide and the surface of the Subplaten	Make sure no paper, dust, or foreign objects are attached or have accumulated.	Cleaning (If there is an ink stain, wipe with dry, clean cloth after cleaning the ink stain with damp cloth.)
Timing Fence (Slit plate for CR encoder detection.)	Is there any accumulation or adhesion of paper dust or foreign matter?	Clean If there is any damage, replace the part.
Rail on the CR guide frame	Make sure there are no foreign objects attached.	Cleaning
P_REAR sensor and P_FRONT sensor surface	Make sure no paper, dust, or foreign objects are attached or have accumulated.	Cleaning

6.2 Lubrication and Glue

In this printer, as necessary, the lubricants specified below should be used for oiling and adhesion during disassembly and assembly operations.

Table 6-3. Grease and Glue Application

Type	Name	Amount	Company	Part #	Location
Grease	Super-Multi Oil #32	n/a	Idemitsu	n/a	Carriage rail bearings
	G-26 (Molicoat EM-60L)	40g (n/a)	EPSON (Dow Corning Asia)	B702600001	Other parts on mechanism
Glue	Screw lock	1,000g	EPSON	B730200200	Screw lock (blue)



Do not apply any other oils, lubricants, or glues than those described in this manual; otherwise printer parts may be damaged or their useful life may be shortened.

6.2.1 Lubricating the CR Guide Rail

- Lubricant: Super-Multi Oil #32 (Idemitsu)

Apply lubricant to the four points as shown below on the CR Guide Rail (carriage roller running surface).



Before applying lubricant, clean the surface.

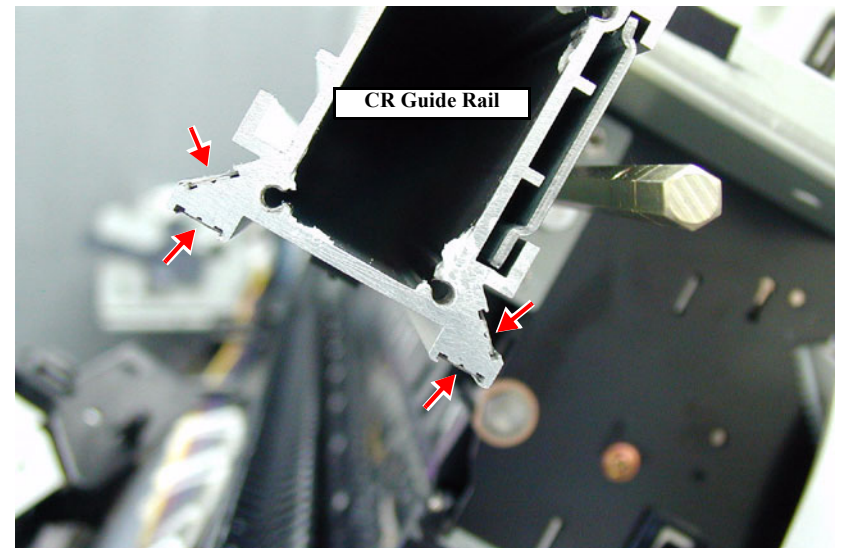

Figure 6-1. Lubricating Positions on the CR Guide Rail

CHAPTER

7

APPENDIX

7.1 Connectors

- Main Board (C472 MAIN)

Table 7-1. Main Board Connectors List

CN.No.	Pins	Color	Connected to	Remarks
CN1	12	White	P/S board	Lock type
CN2	16		PANEL	FFC, lock type
CN3	36		H-UDI36	
CN4	5	Yellow	D/A_OUT	(Not used)
CN5	90		ROM_DIMM	
CN6	21		CSIC	FFC
CN7	5	Red	S_I/O(DEBUGER)	(Not used)
CN8	24		CR_FFC1	FFC, lock type
CN9	24		CR_FFC3	FFC, lock type
CN10	24		CR_FFC2	FFC, lock type
CN11	36		IEEE1284 (parallel port)	
CN12	4		USB	(Not used)
CN13	36		TYPE_B	
CN14	3	White	CR_MOT	Lock type, with relay connector
CN15	2	White	PF_MOT	Lock type, with relay connector
CN16	5	White	PF_ENC	
CN17	4	White	PUMP_MOT	With relay connector
CN18	2	Blue	P/S_FAN	
CN19	2	Black	FAN1	With relay connector
CN20	2	Yellow	FAN2	With relay connector
CN21	2	Red	FAN3	* Stylus Pro 9600 only
CN22	3	Blue	P_THICK0.3	
CN23	3	Yellow	COVER_L	
CN24	3	White	CR_ORG	
CN25	3	Black	I/H_LEVER	(Not used)
CN26	3	Red	P_THICK	
CN27	4	Black	P_REAR	
CN28	4	Yellow	P_FRONT	(Not used)
CN29	4	Red	HD_SLID	
CN30	15		ROLL_UNIT (option unit)	* Stylus Pro 9600 only
CN31	2	White	H_FAN	
CN33	3	White	RESET	

Table 7-1. Main Board Connectors List (continued)

CN.No.	Pins	Color	Connected to	Remarks
CN35	4		USB2.0	Right side (AC side)
CN36	8		IEEE1394	(Not used)
CN37	2		HDD_PS	(Not used)

- Panel Unit

Table 7-2. Panel Unit Connectors List

CN.No.	Pins	Color	Connected to	Remarks
CN1	16		Main Board (CN7)	FCC, lock type

- C472 CR Board

Table 7-3. C472 CR Board Connectors List

CN.No.	Pins	Color	Connected to	Remarks
CN1	24		Main Board (CN8)	FFC, lock type
CN2	24		Main Board (CN10)	FFC, lock type
CN3	17		Print Head1	FFC, lock type
CN4	30		Print Head2	FFC, lock type
CN5	4	Black	P_Edge Sensor	
CN6	5	White	CR Encoder Sensor	
CN7	2	White	Cutter Solenoid	
CN8	4	Black	Main Board (CN10)	FFC, lock type

C472 SUB-B Board

Table 7-4. C472 SUB-B Board Connectors List

CN.No.	Pins	Color	Connected to	Remarks
CN1	20		Main Board (CN6)	FFC
CN2	2	White	I/H Lever Sensor	
CN3	7		CSIC Relay Board (Black)	FFC
CN4	7		CSIC Relay Board (Light Black)	FFC
CN5	7		CSIC Relay Board (Cyan)	FFC
CN6	7		CSIC Relay Board (Light Cyan)	FFC
CN7	7		CSIC Relay Board (Magenta)	FFC
CN8	7		CSIC Relay Board (Light Magenta)	FFC
CN9	7		CSIC Relay Board (Yellow)	FFC
CN10	7		Maintenance Tank Relay Board	FFC

 Power Supply Board

Table 7-5. Power Supply Board Connector List

CN.No.	Pins	Color	Connected to	Remarks
CN001	12	White	Main Board (CN1)	Lock type
CN301	2	White	AC Inlet	Lock type

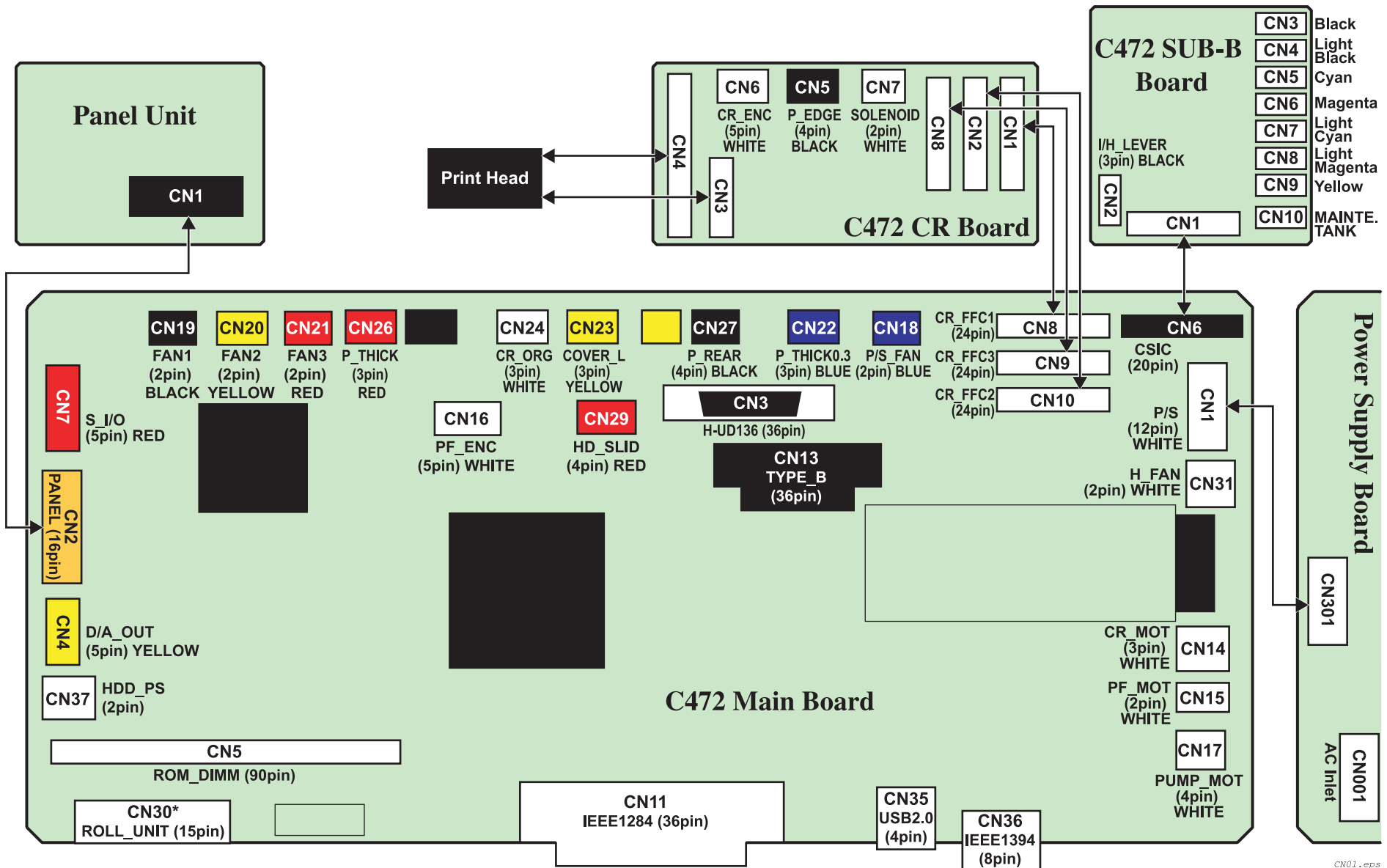

CW01.eps

Figure 7-1. Stylus Pro 7600/9600 Connectors

7.2 Component Layout

Will be established by the next revision.

7.3 Circuit Diagrams

The circuit diagrams of the following circuit boards are shown on the following pages:

- C472 MAIN BOARD
- C472SUB BOARD
- C472SUB-B BOARD

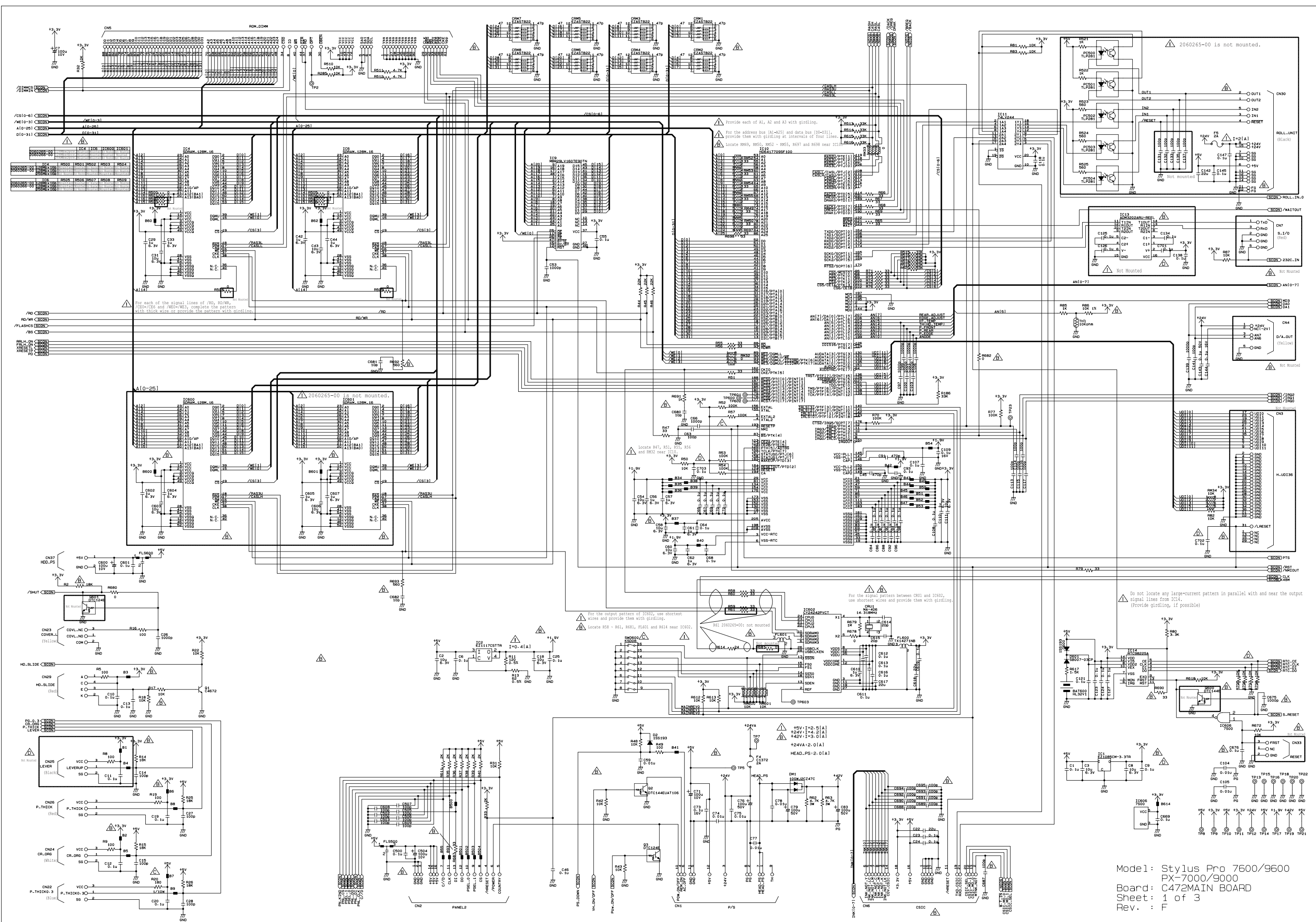

Model: Stylus Pro 7600/9600
 Board: C472MAIN BOARD
 Sheet: 1 of 3
 Rev.: F

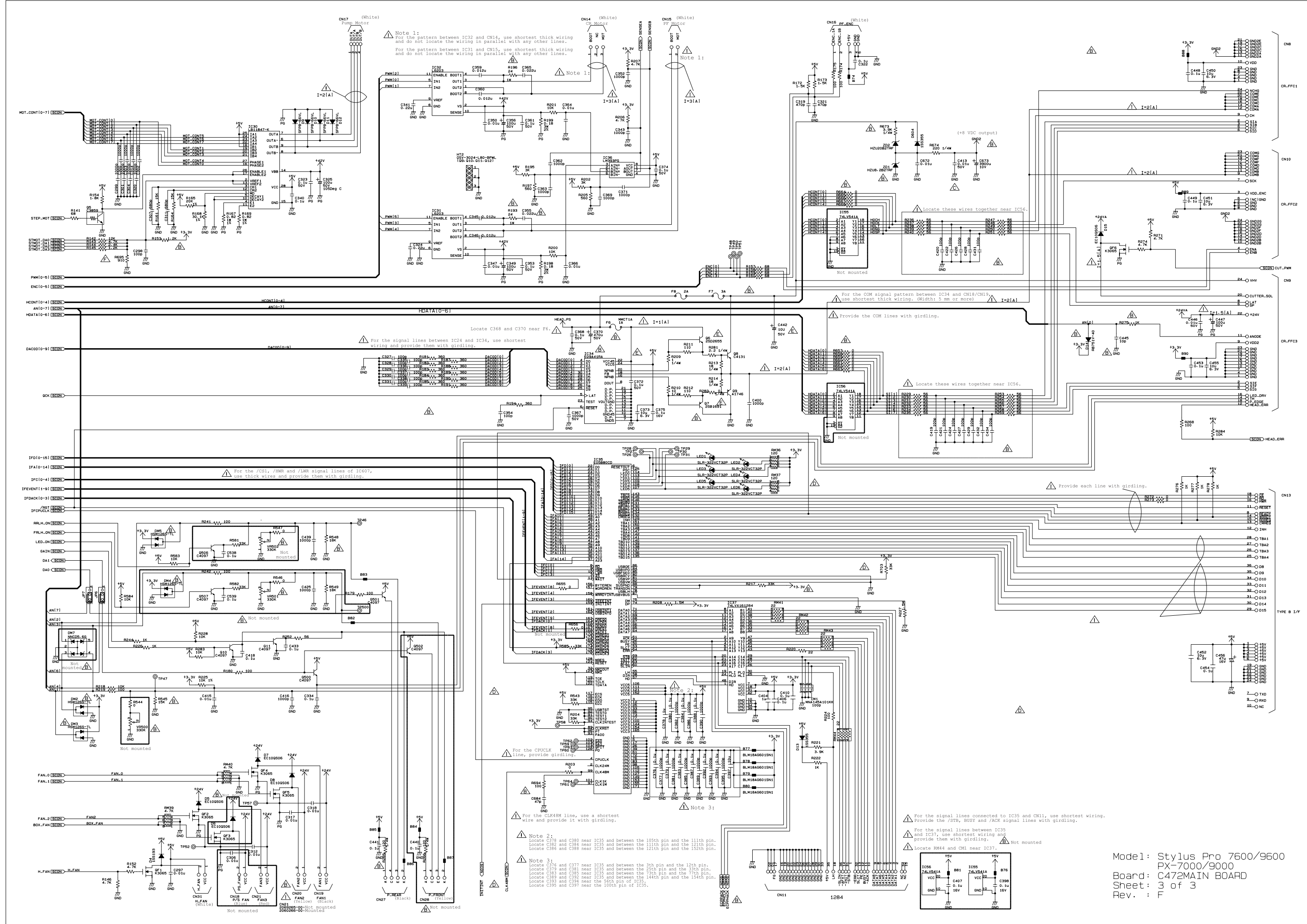

Note 1:
For the pattern between IC32 and CN14, use shortest thick wiring and do not locate the wiring in parallel with any other lines.
For the pattern between IC31 and CN15, use shortest thick wiring and do not locate the wiring in parallel with any other lines.

Note 1:
I=3(A)

Note 1:
I=3(A)

Note 1:
I=2(A)

Locate C368 and C370 near F6.

For the signal lines between IC24 and IC34, use shortest wiring and provide them with girdling.

For the COM signal pattern between IC34 and CN18/CN19, use shortest thick wiring. (Width: 5mm or more)

Provide the COM lines with girdling.

For the /CS1, /HWR and /LWR signal lines of IC607, use thick wires and provide them with girdling.

Provide each line with girdling.

For the CPUCLK line, provide girdling.

For the CLK48M line, use a shortest wire and provide it with girdling.

Note 2:
Locate C378 and C380 near IC35 and between the 10th pin and the 11th pin.
Locate C382 and C384 near IC35 and between the 11th pin and the 12th pin.
Locate C386 and C388 near IC35 and between the 13th pin and the 15th pin.

Note 3:
Locate C379 and C381 near IC35 and between the 12th pin and the 13th pin.
Locate C383 and C385 near IC35 and between the 14th pin and the 15th pin.
Locate C393 and C394 near the 56th pin of IC35.
Locate C395 and C397 near the 10th pin of IC35.

For the signal lines connected to IC35 and IC37, use shortest wiring and provide them with girdling.

Locate RM44 and CM1 near IC37.

Mode1: Stylus Pro 7600/9600
 Board: C47MAIN BOARD
 Sheet: 3 of 3
 Rev.: F

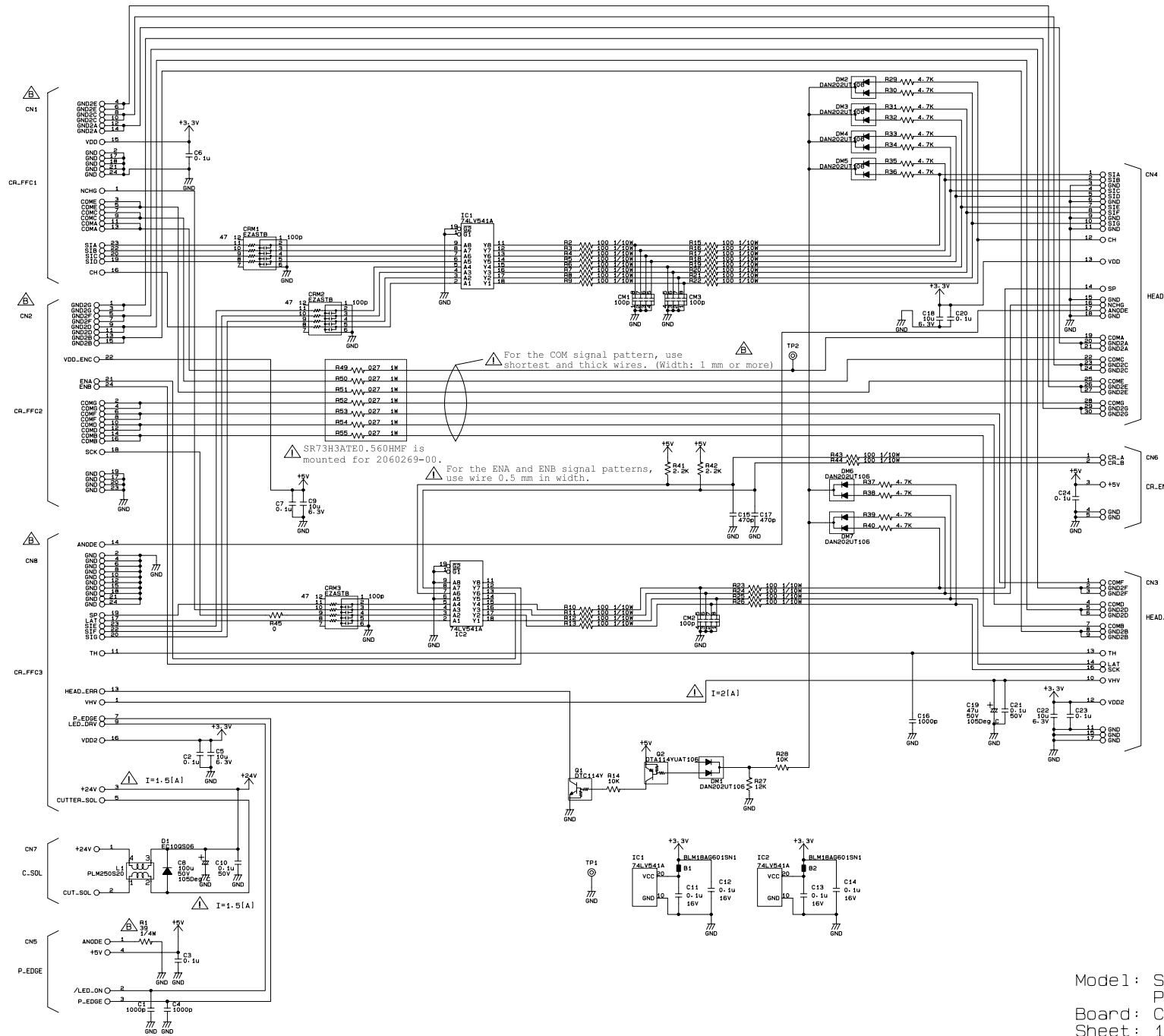

△ GND2*: The pattern width must be 1 mm or more.

Model: Stylus Pro 7600/9600
 Board: C472SUB BOARD
 Sheet: 1 of 1
 Rev.: B

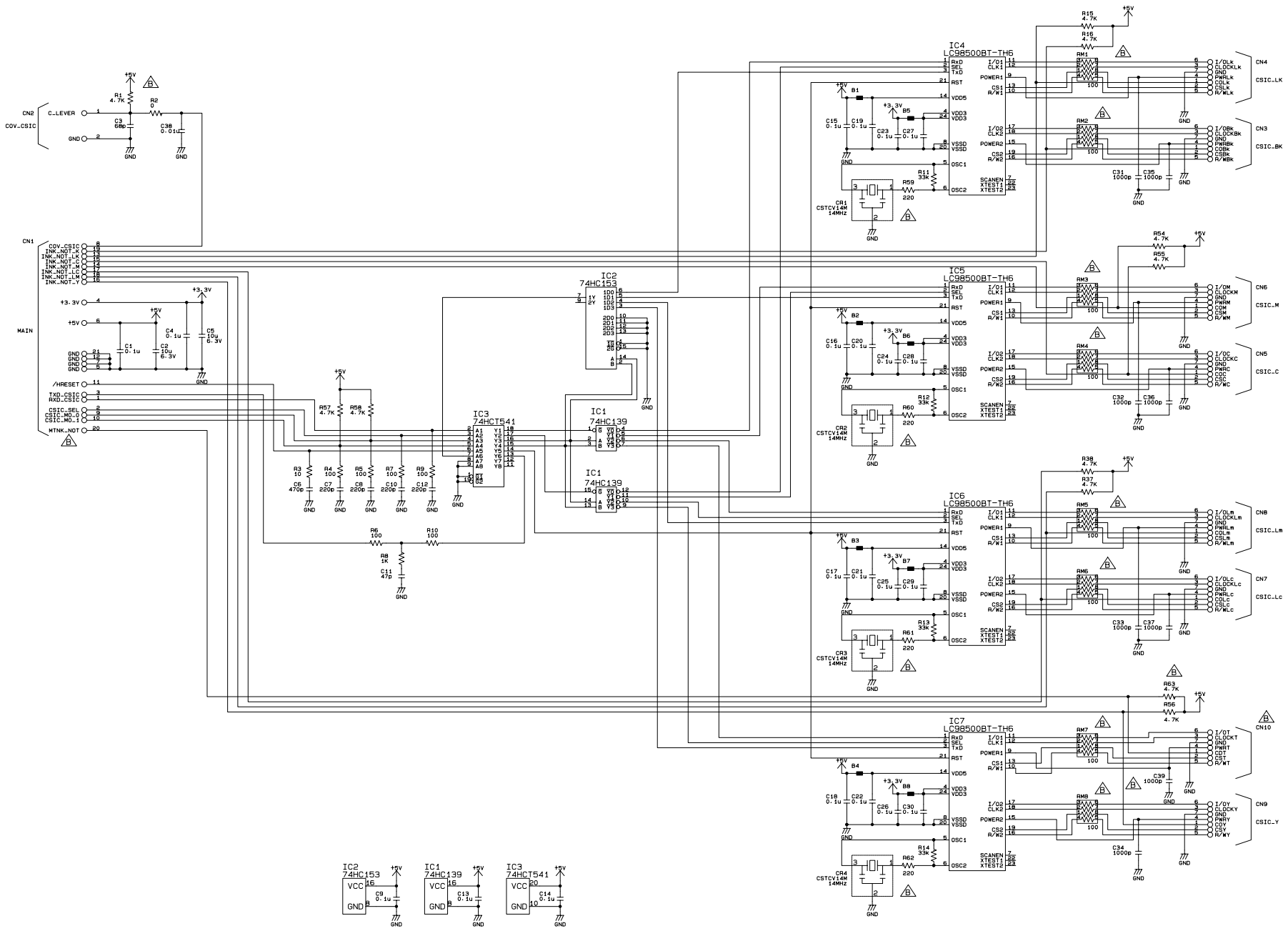

Model: Stylus Pro 7600/9600
 Board: C472SUB-B BOARD
 Sheet: 1 of 1
 Rev.: B

7.4 Exploded Diagrams

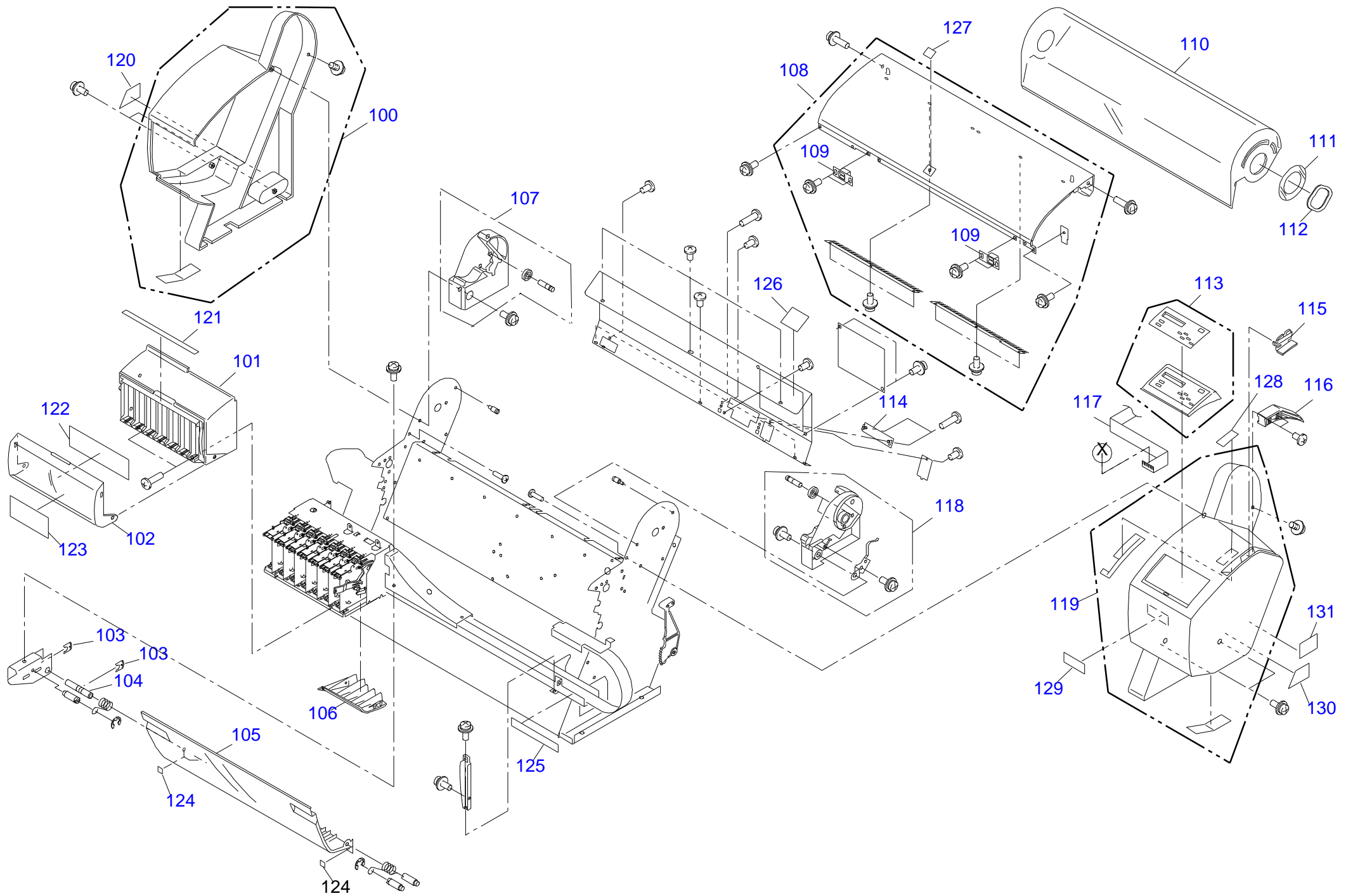

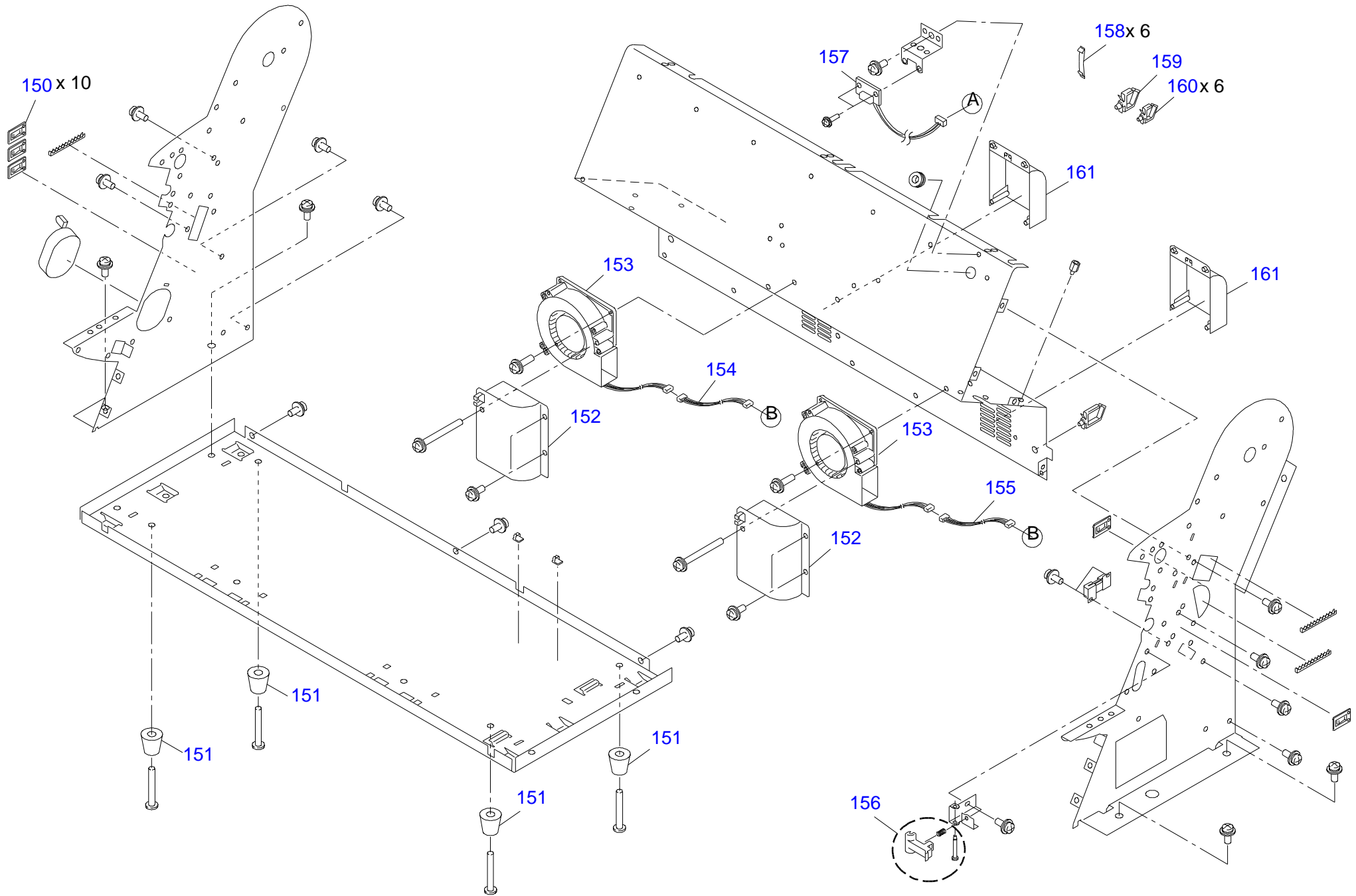

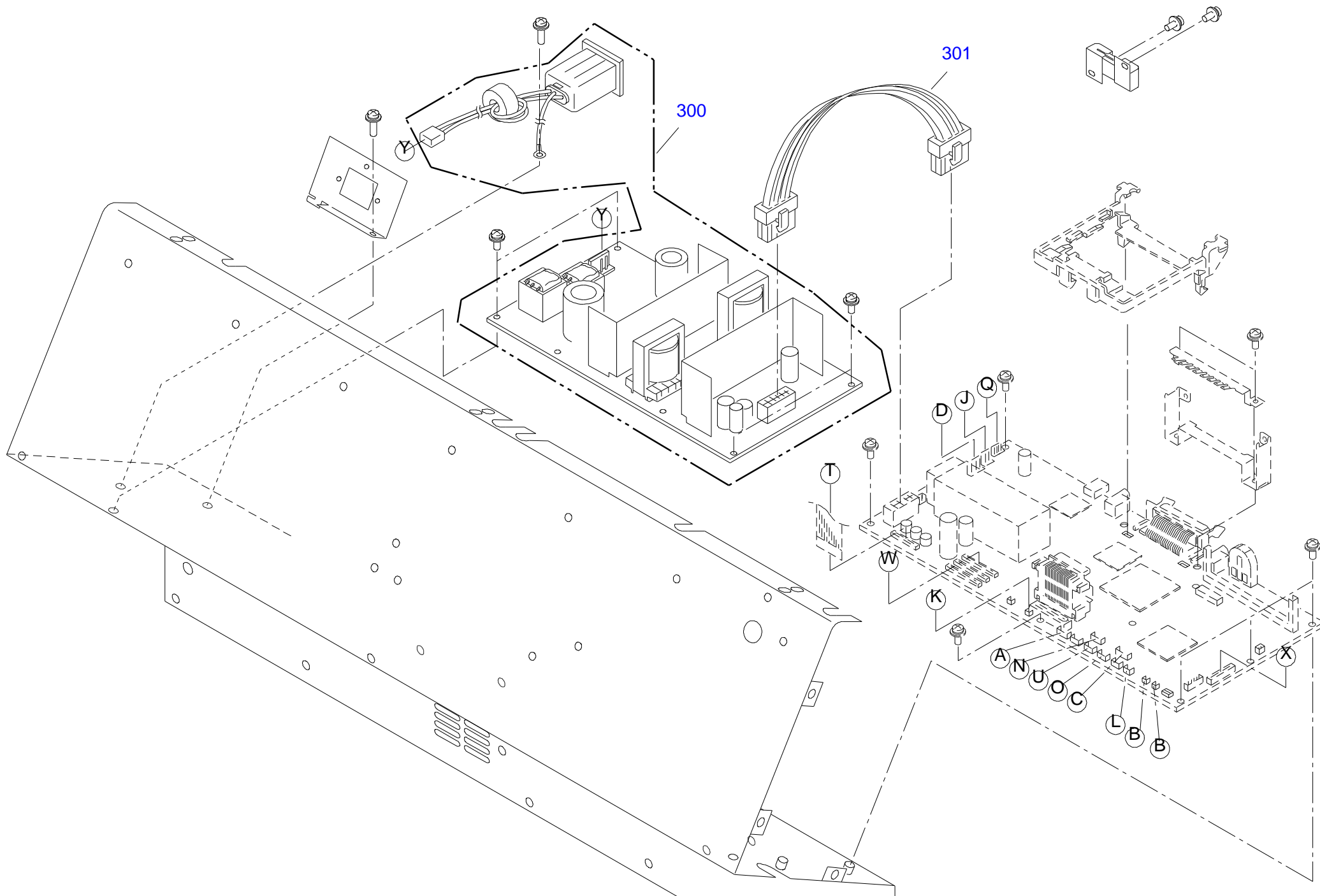

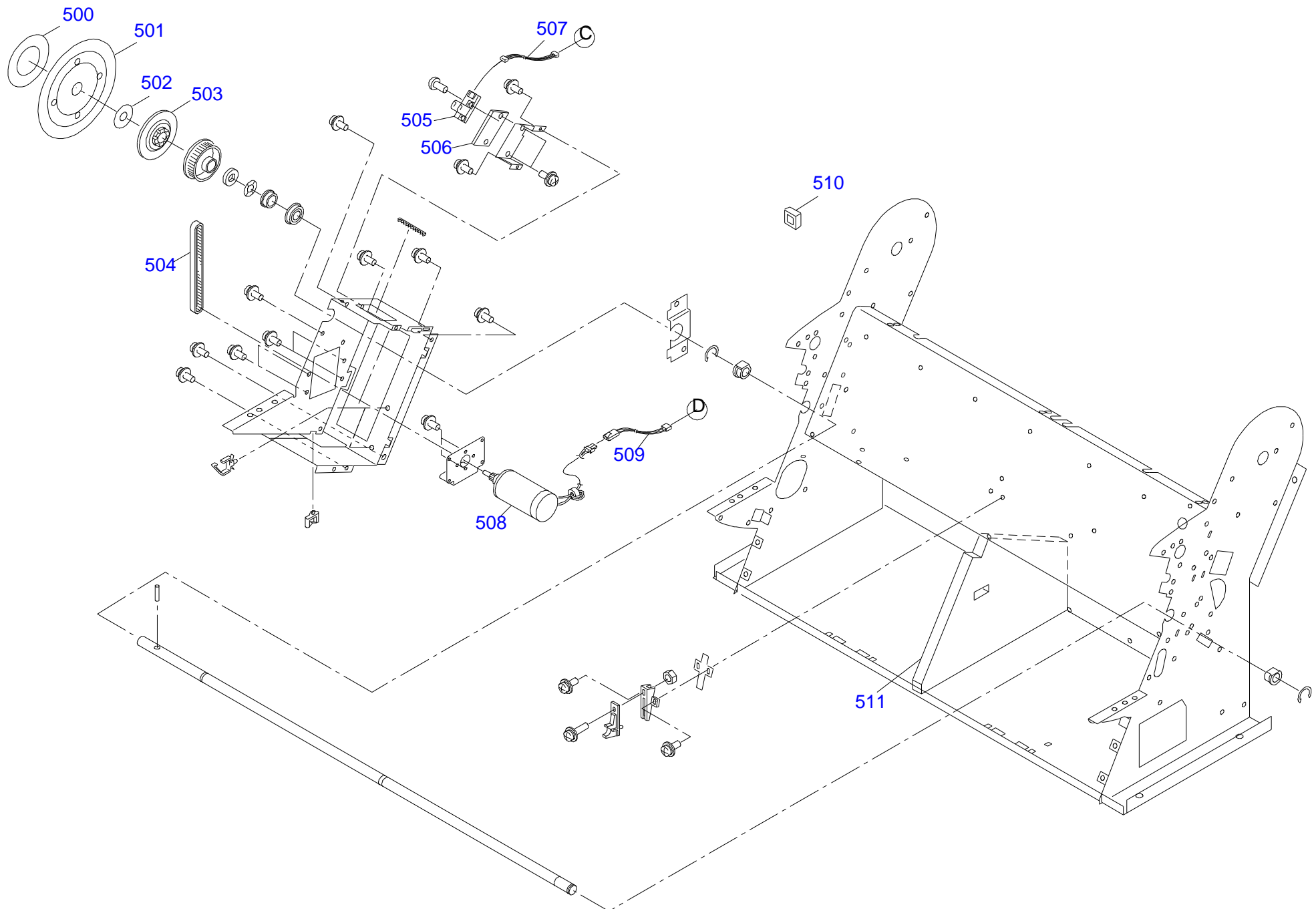

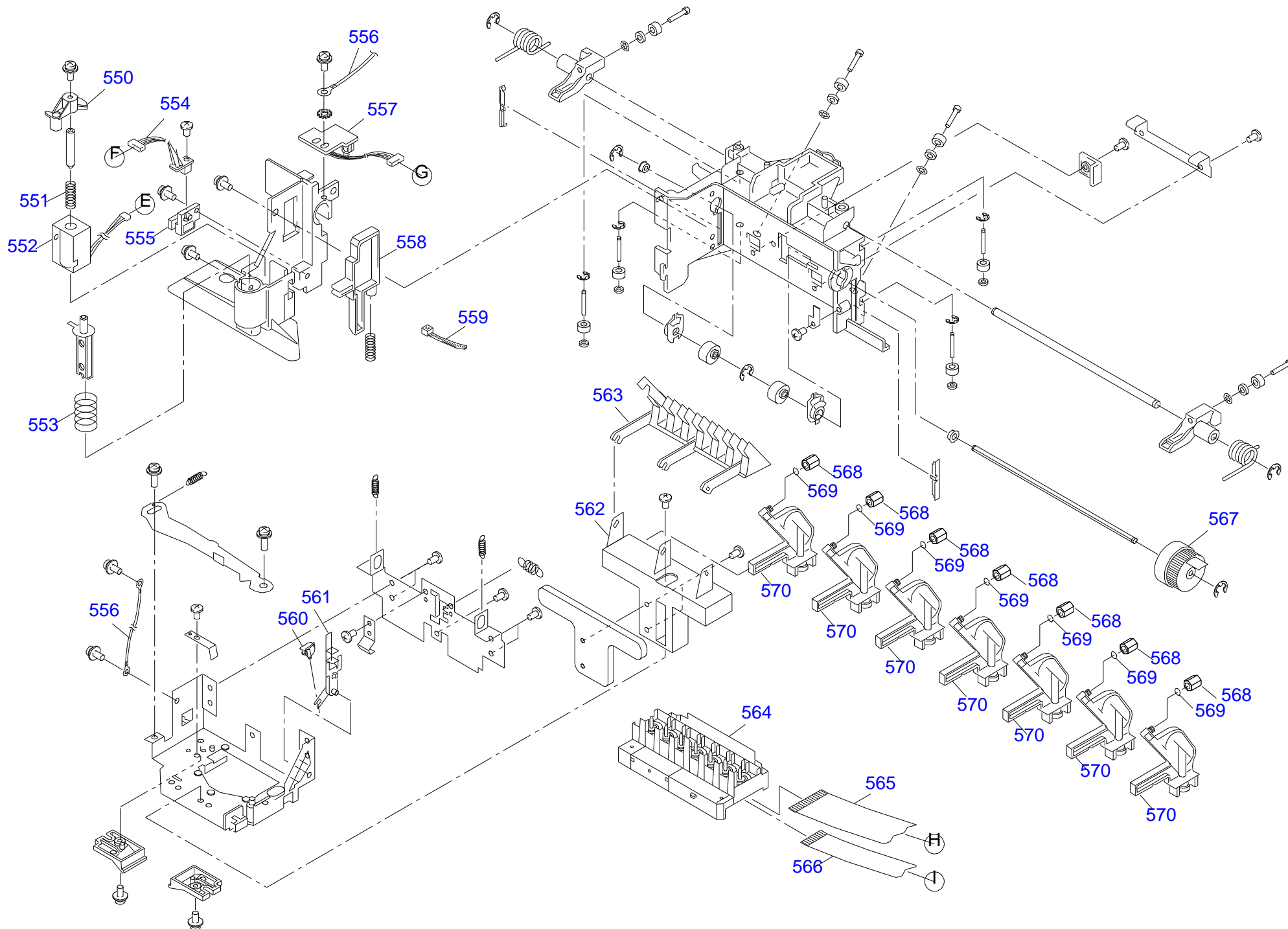

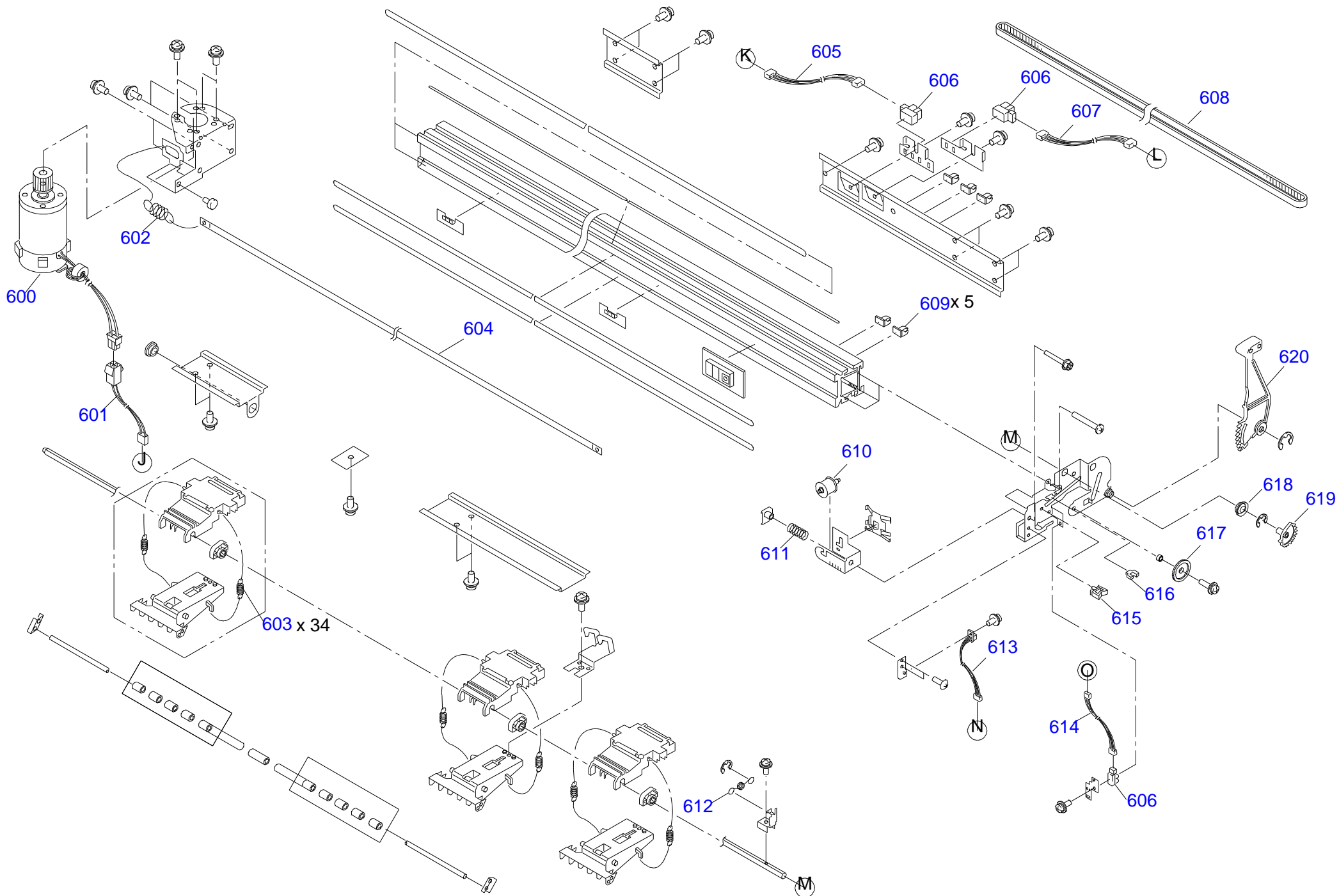

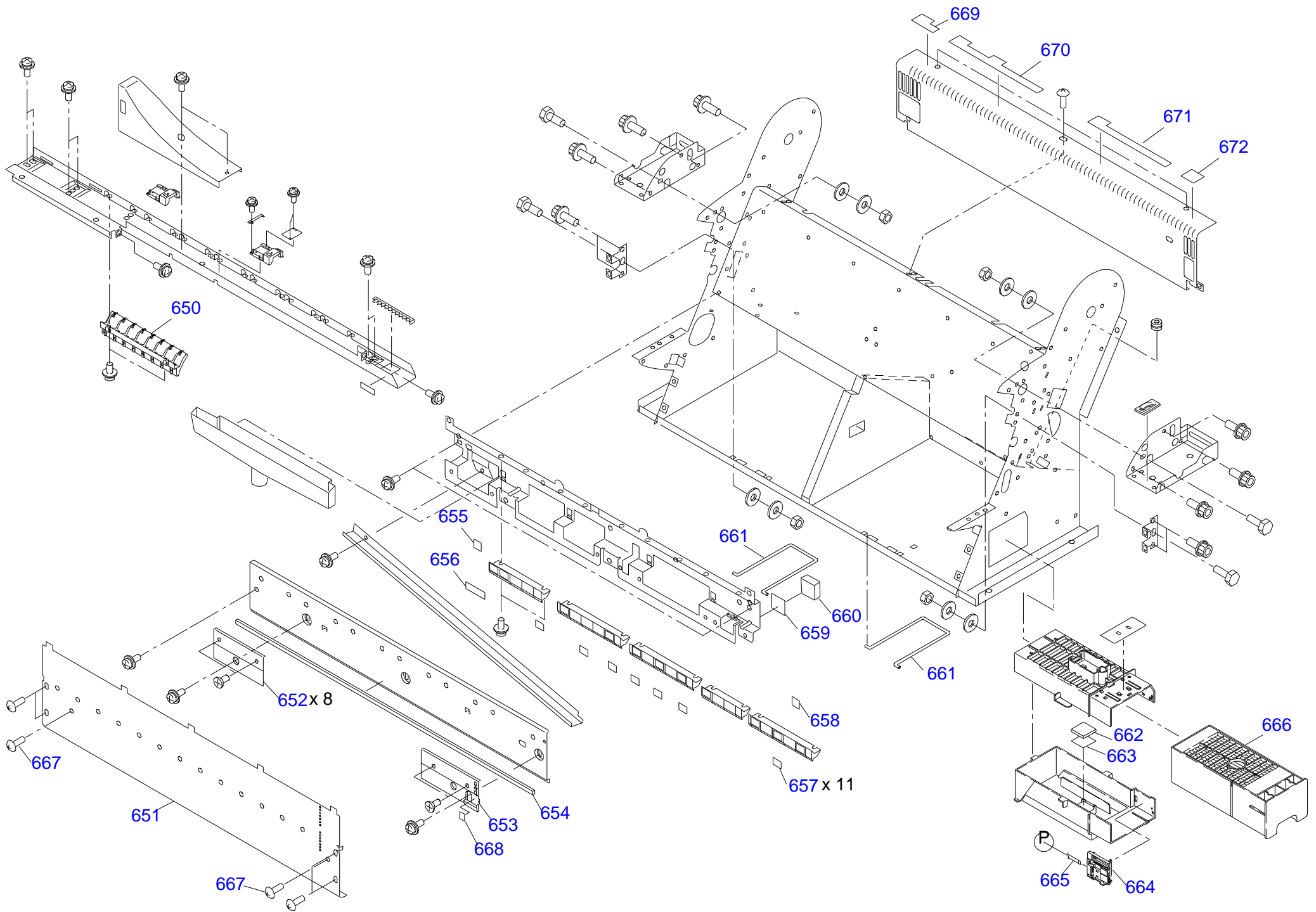

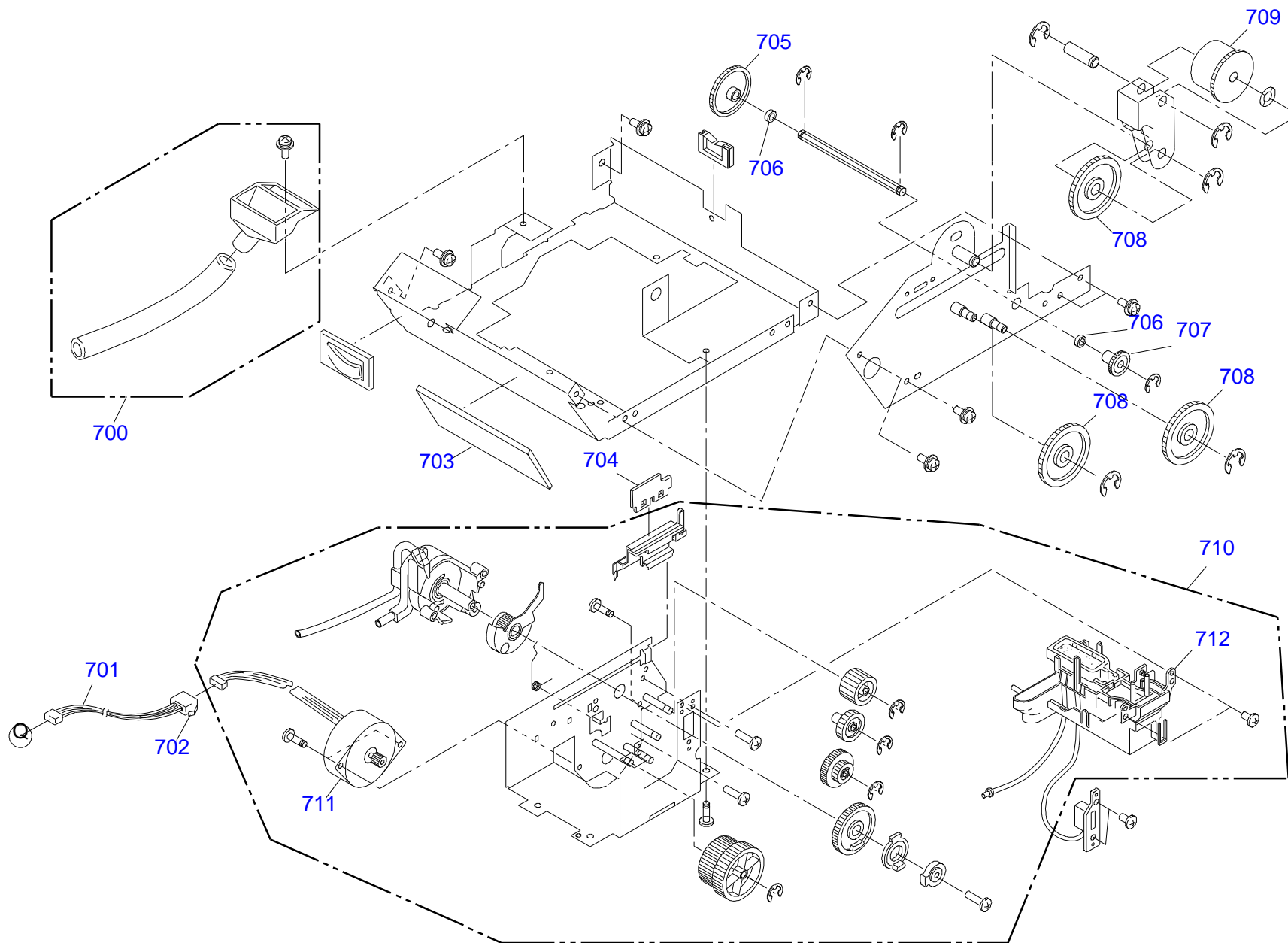

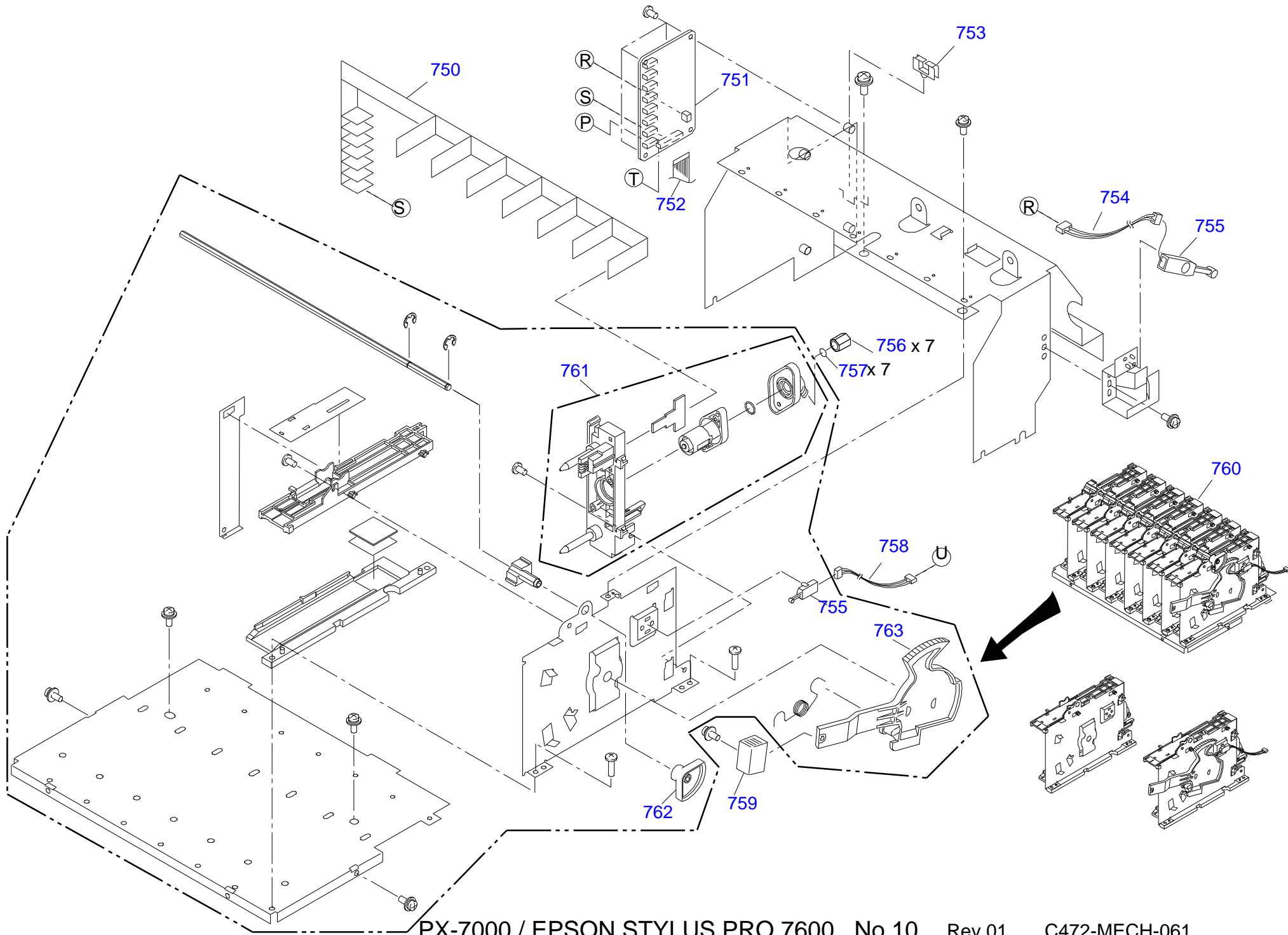

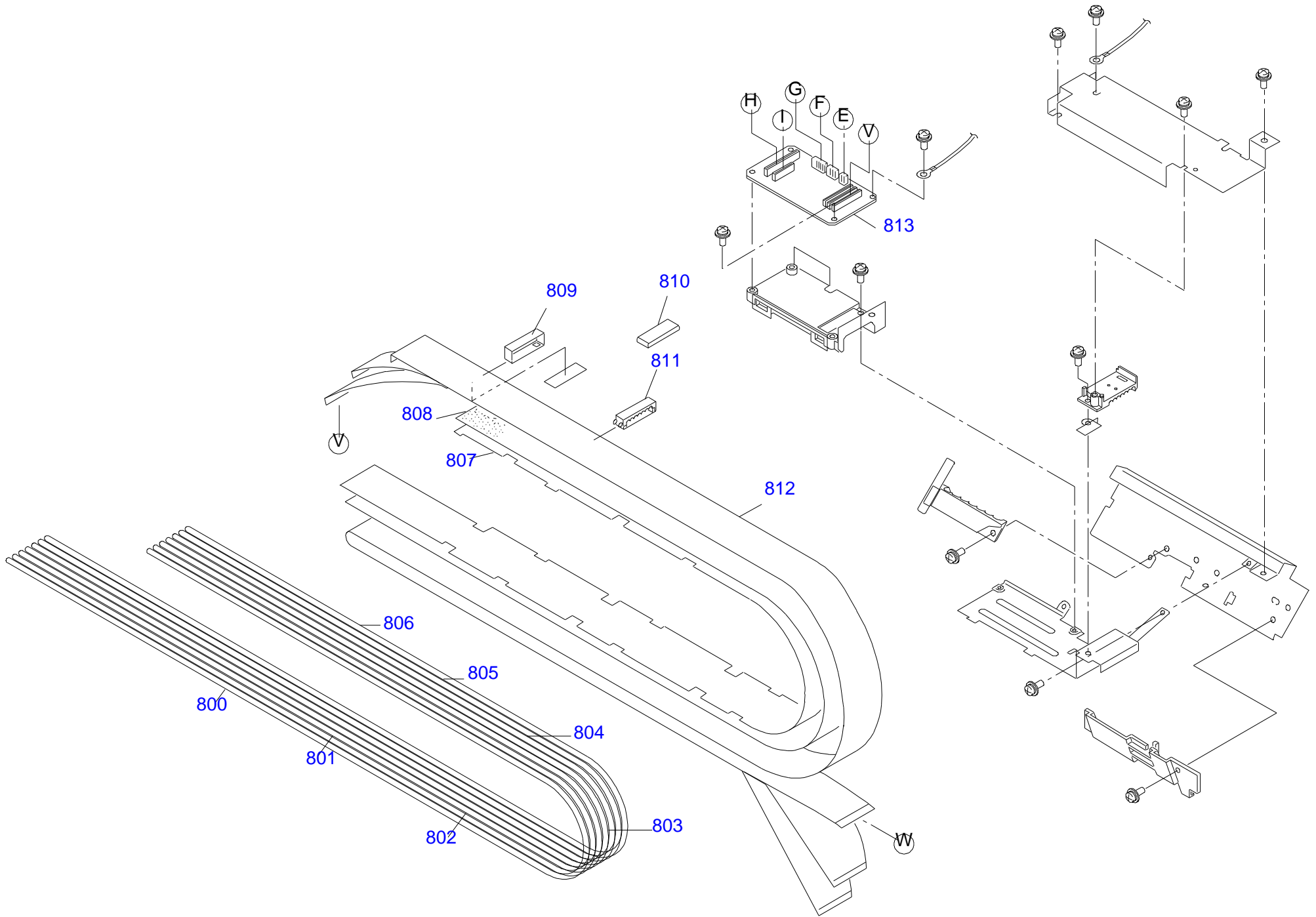

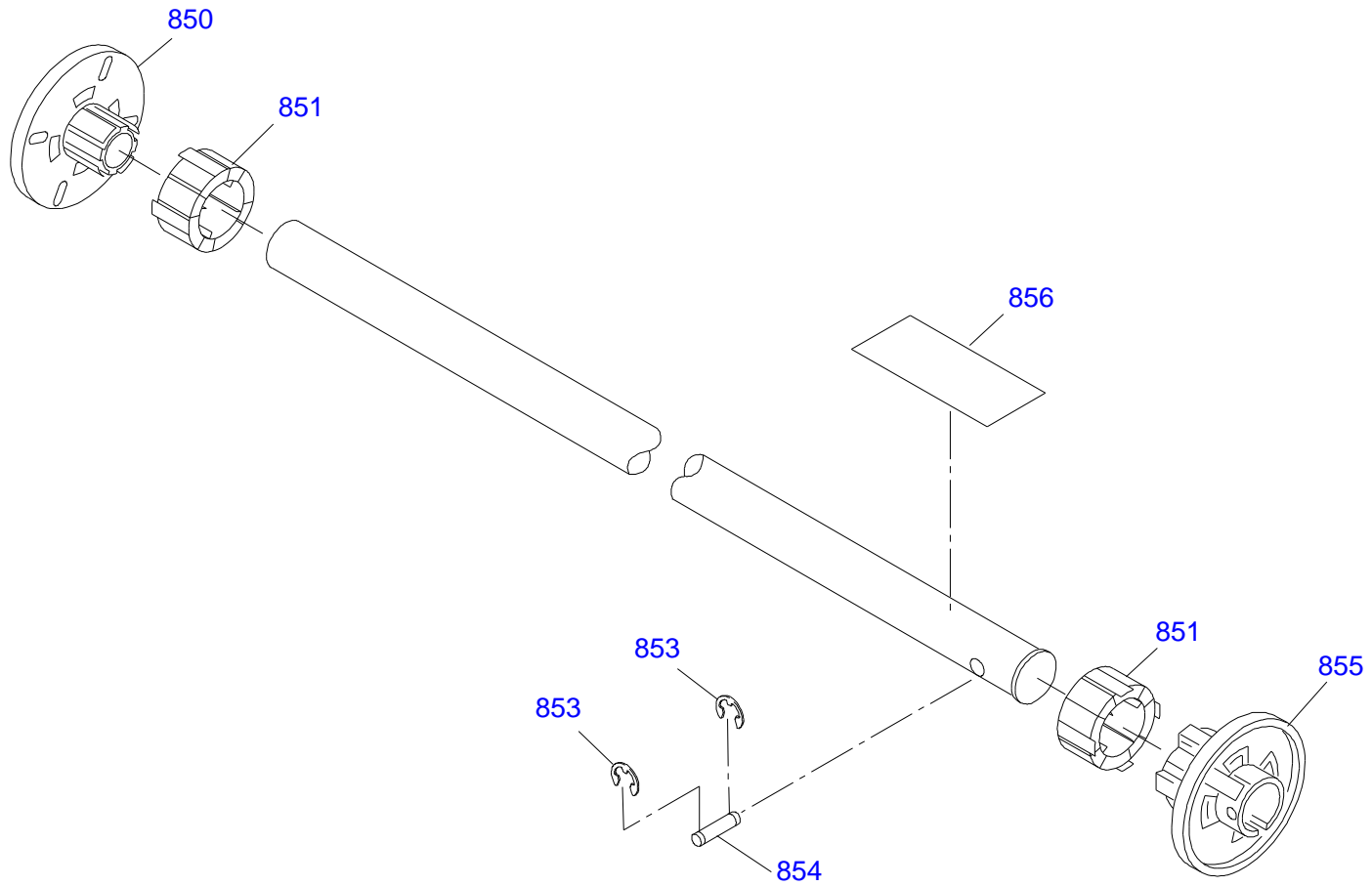

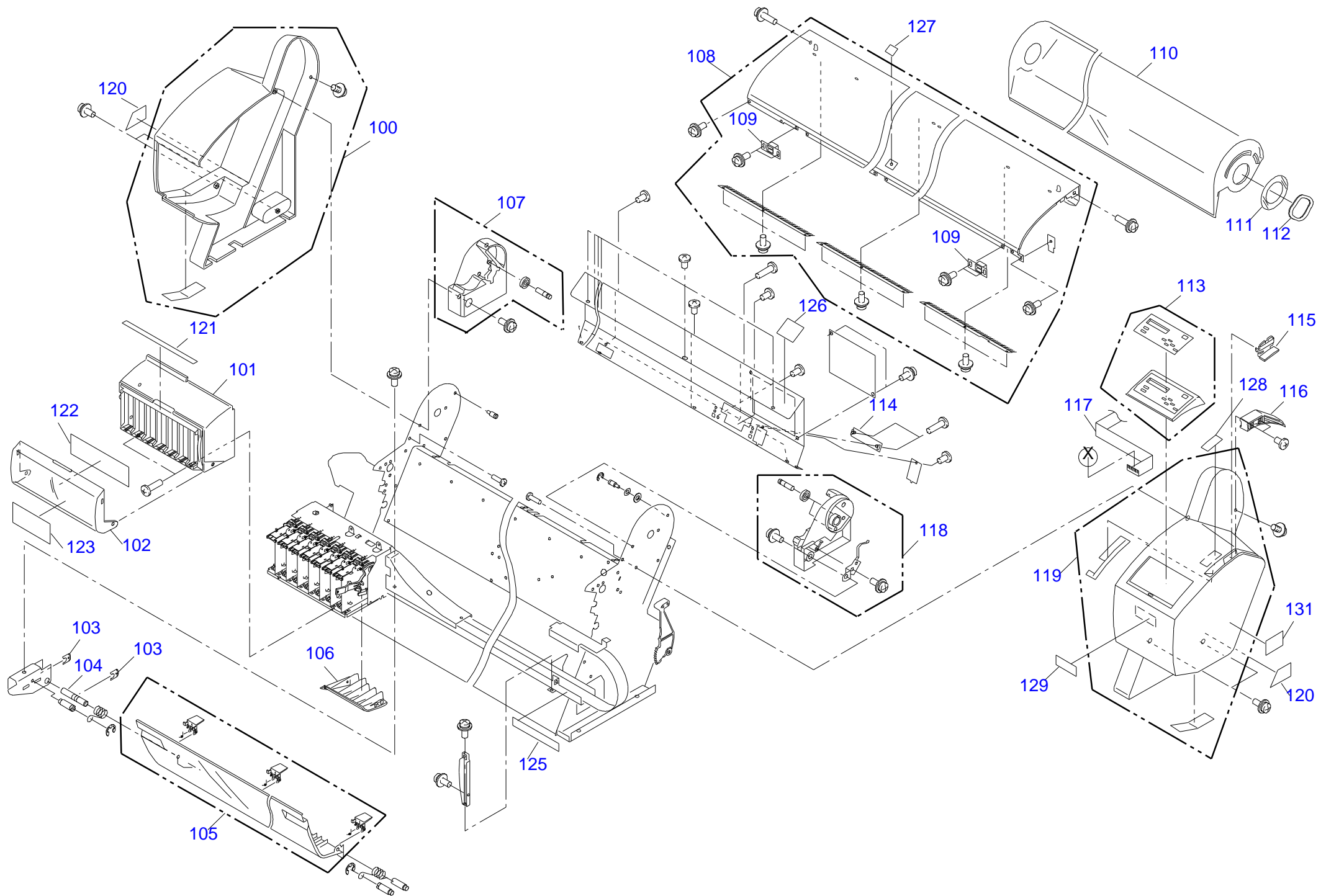

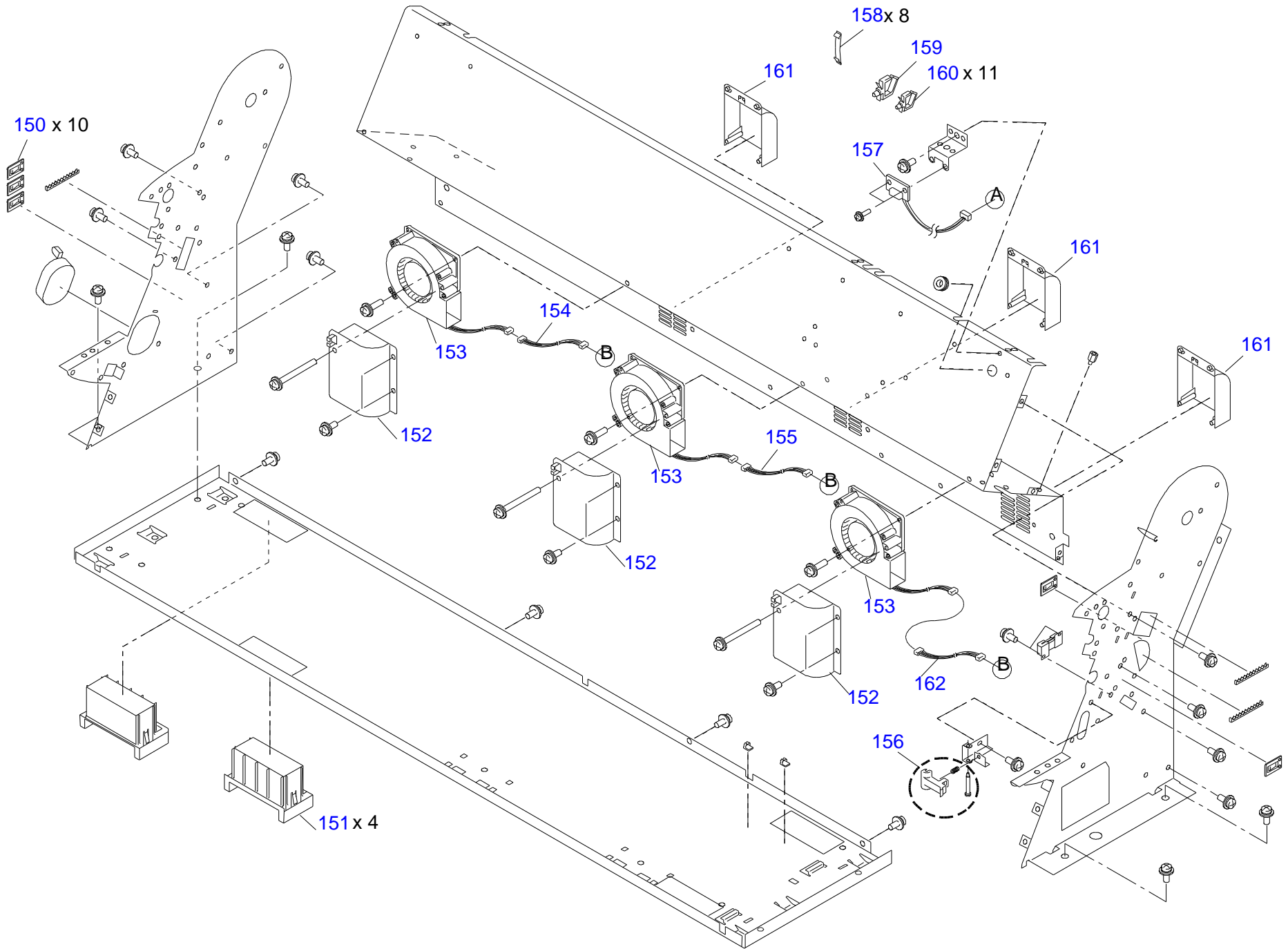

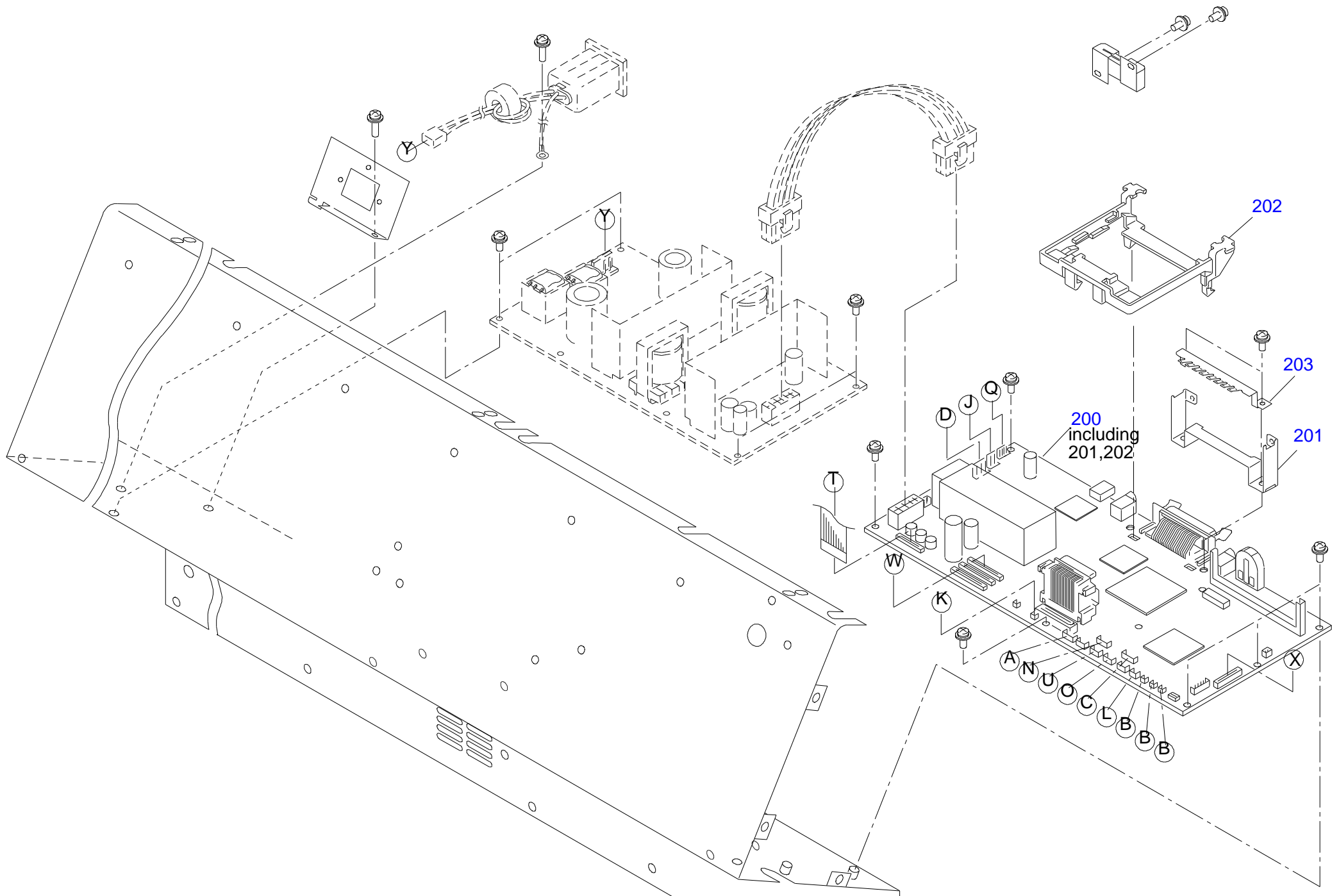

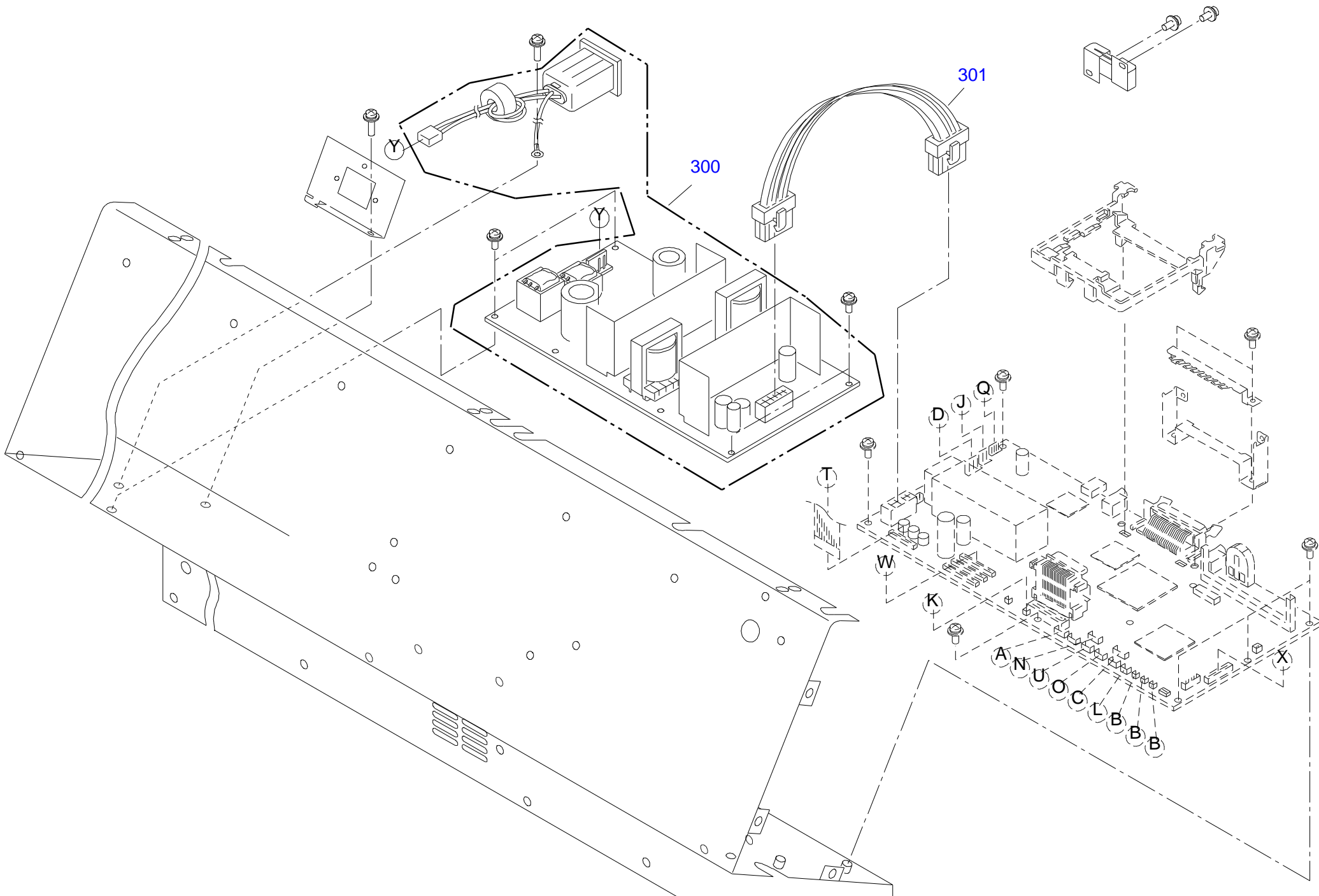

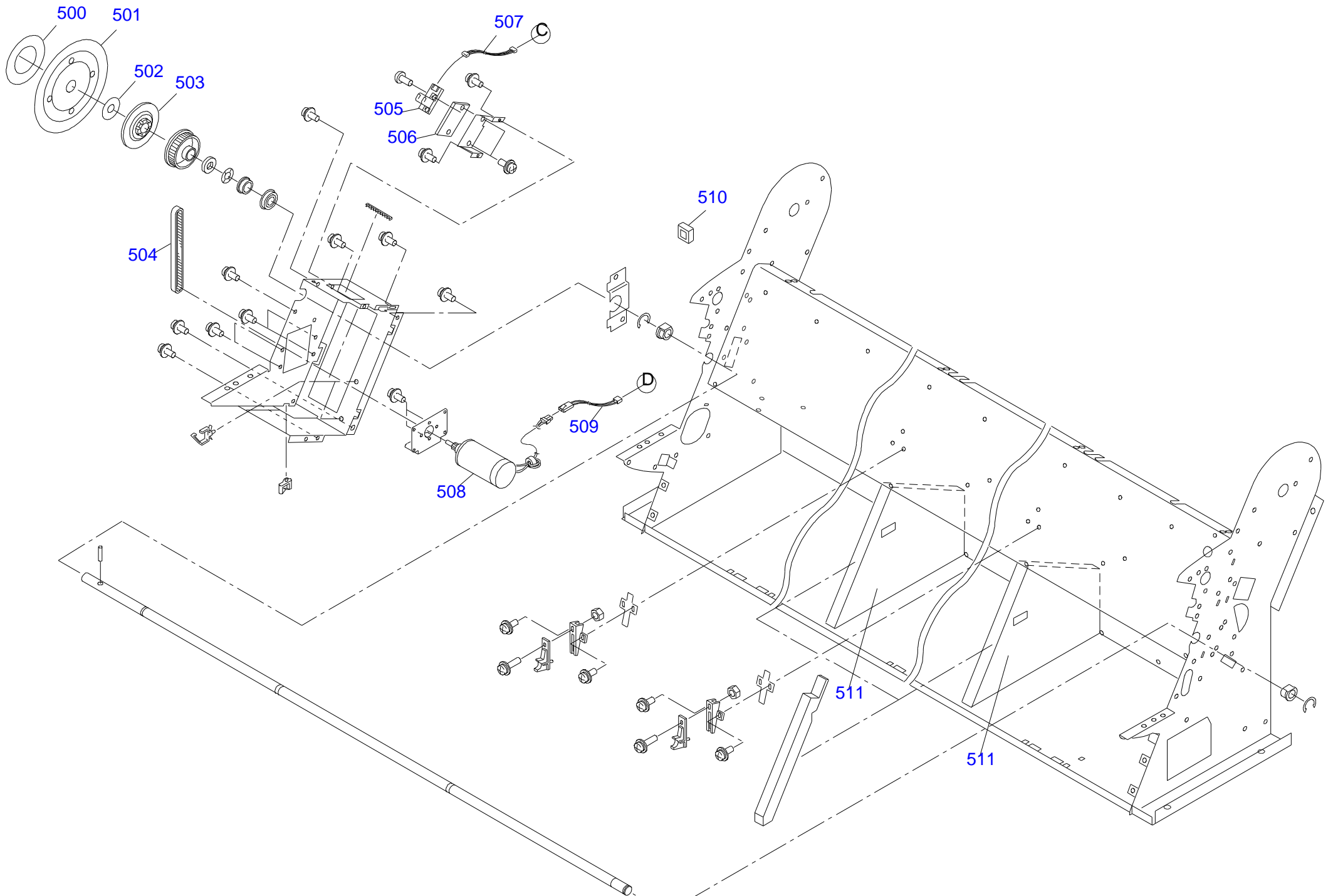

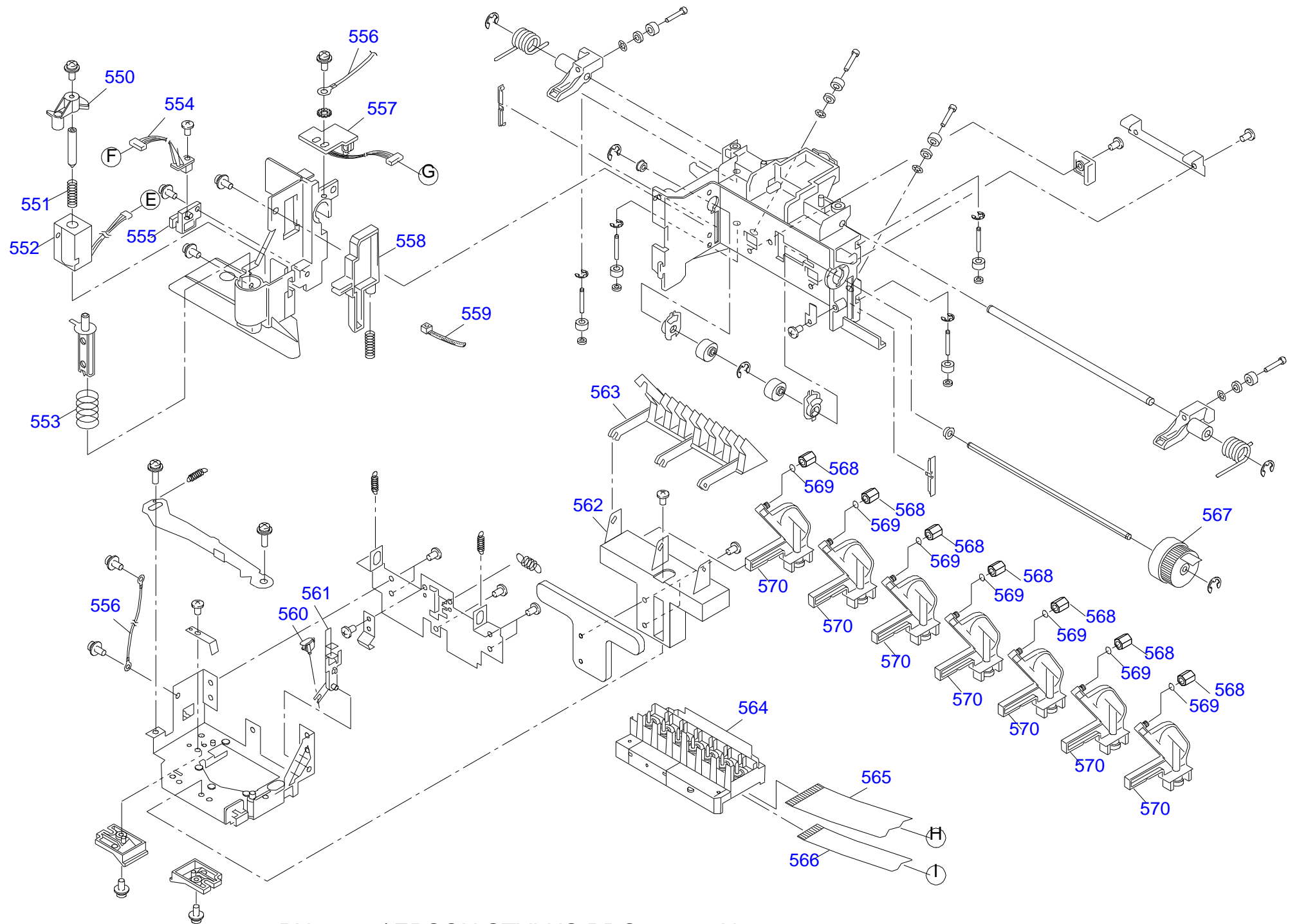

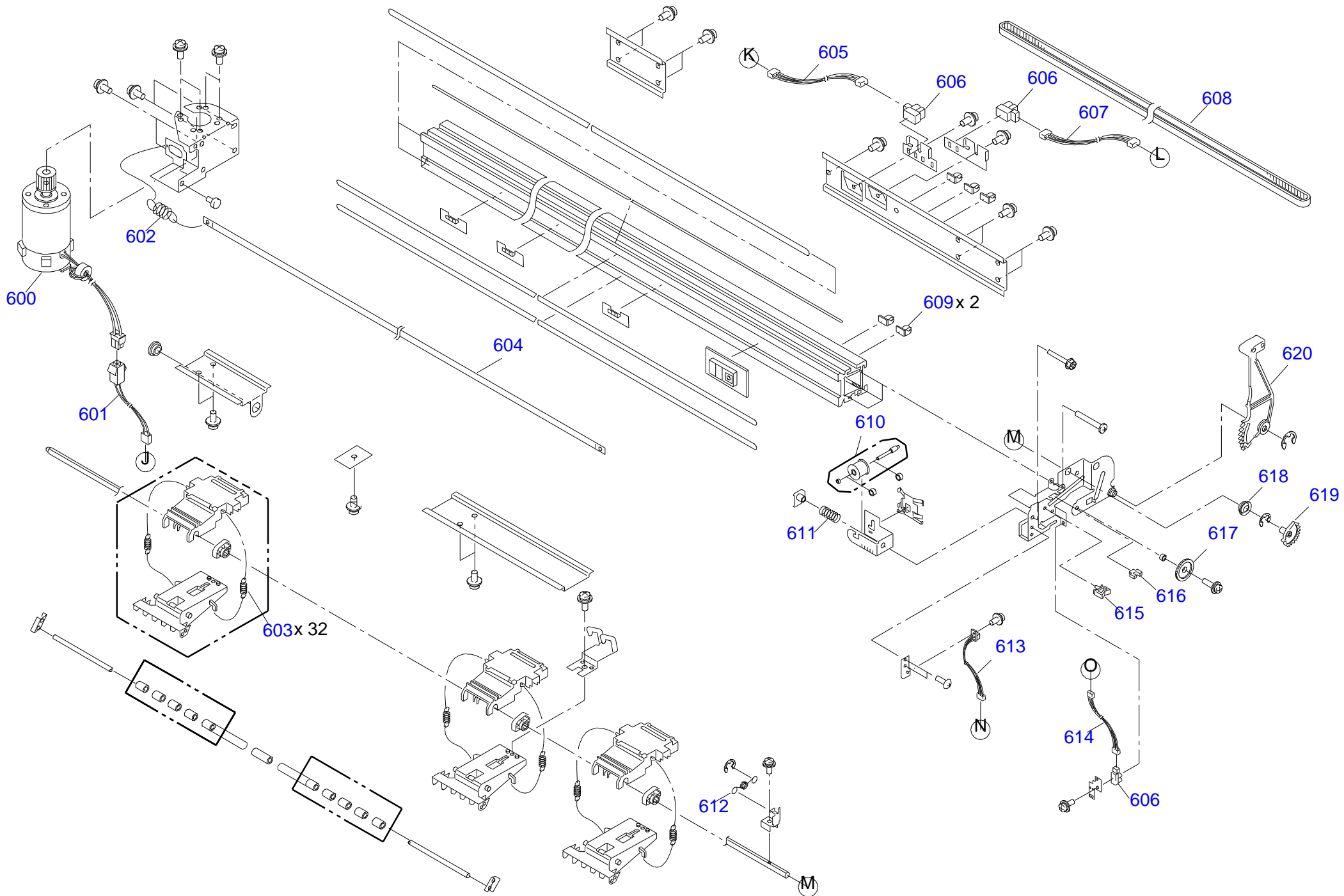

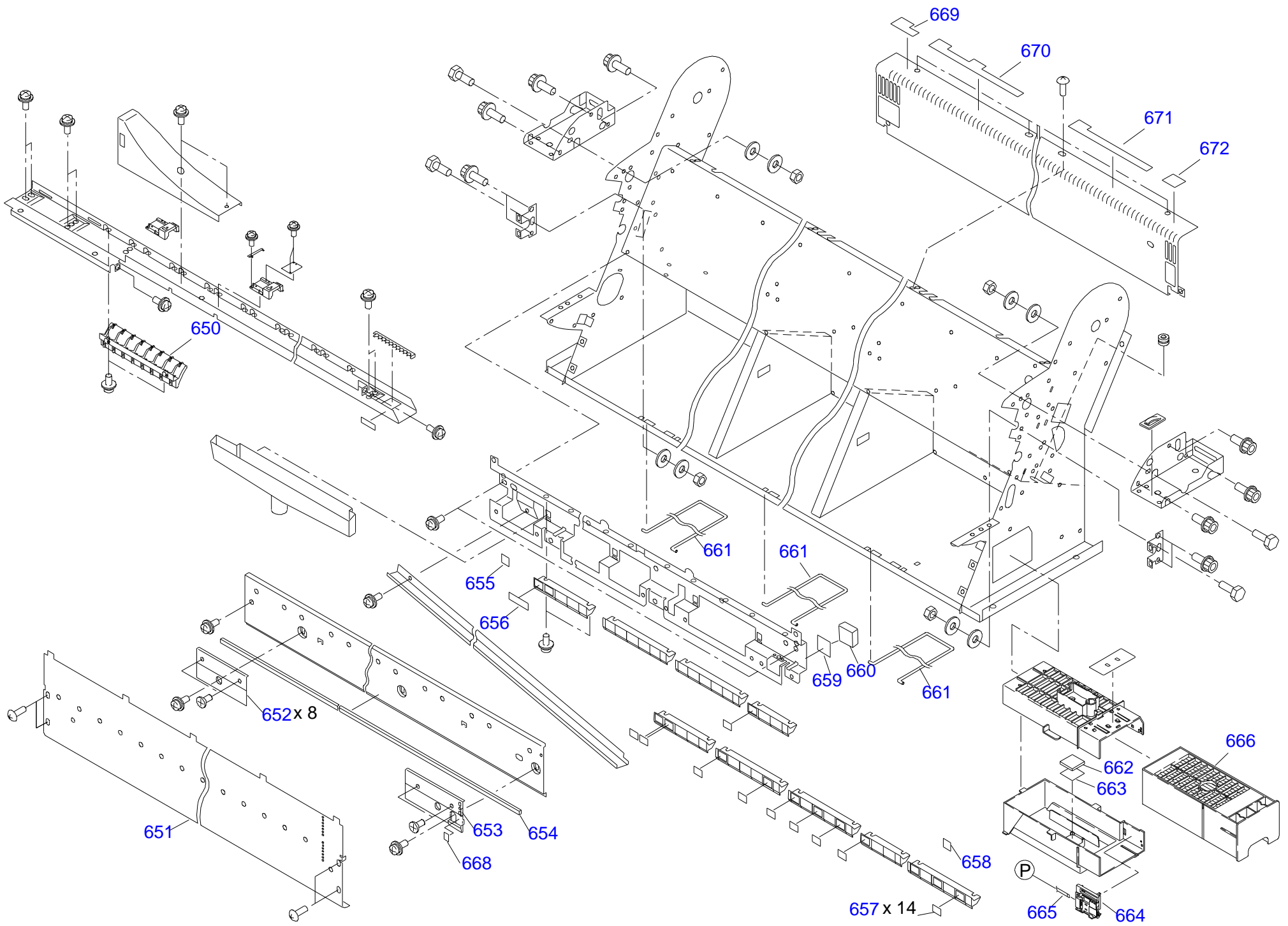

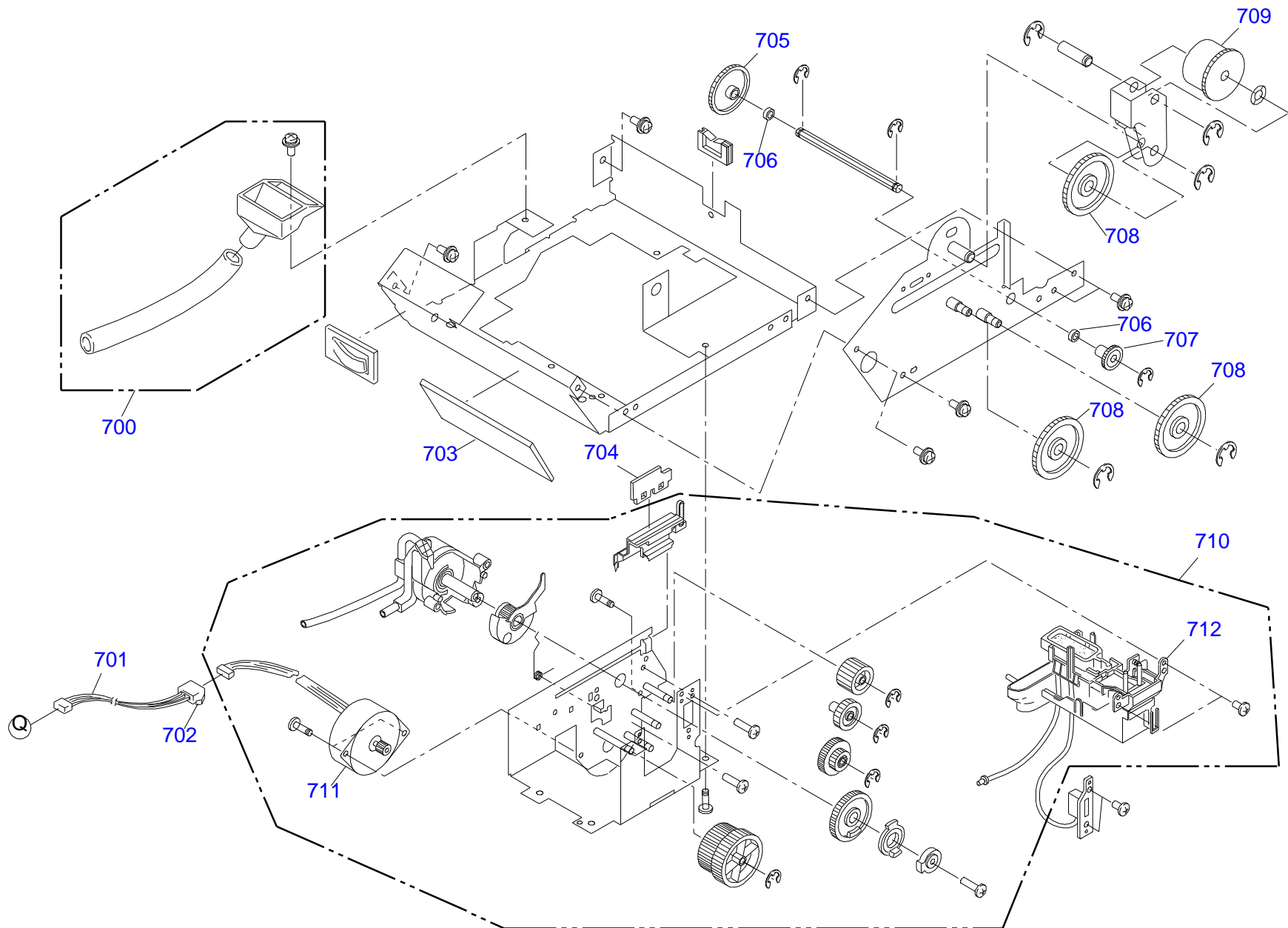

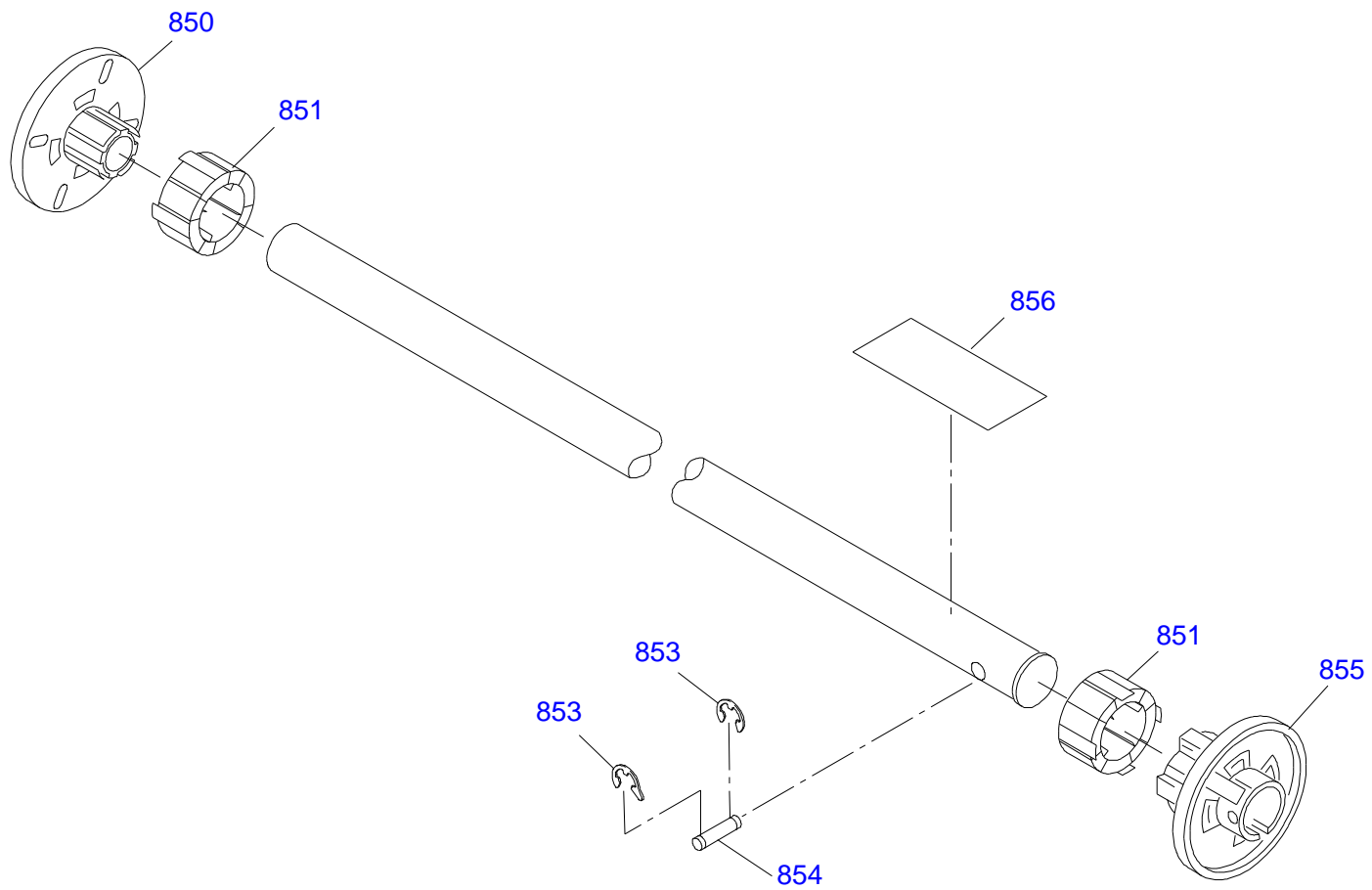

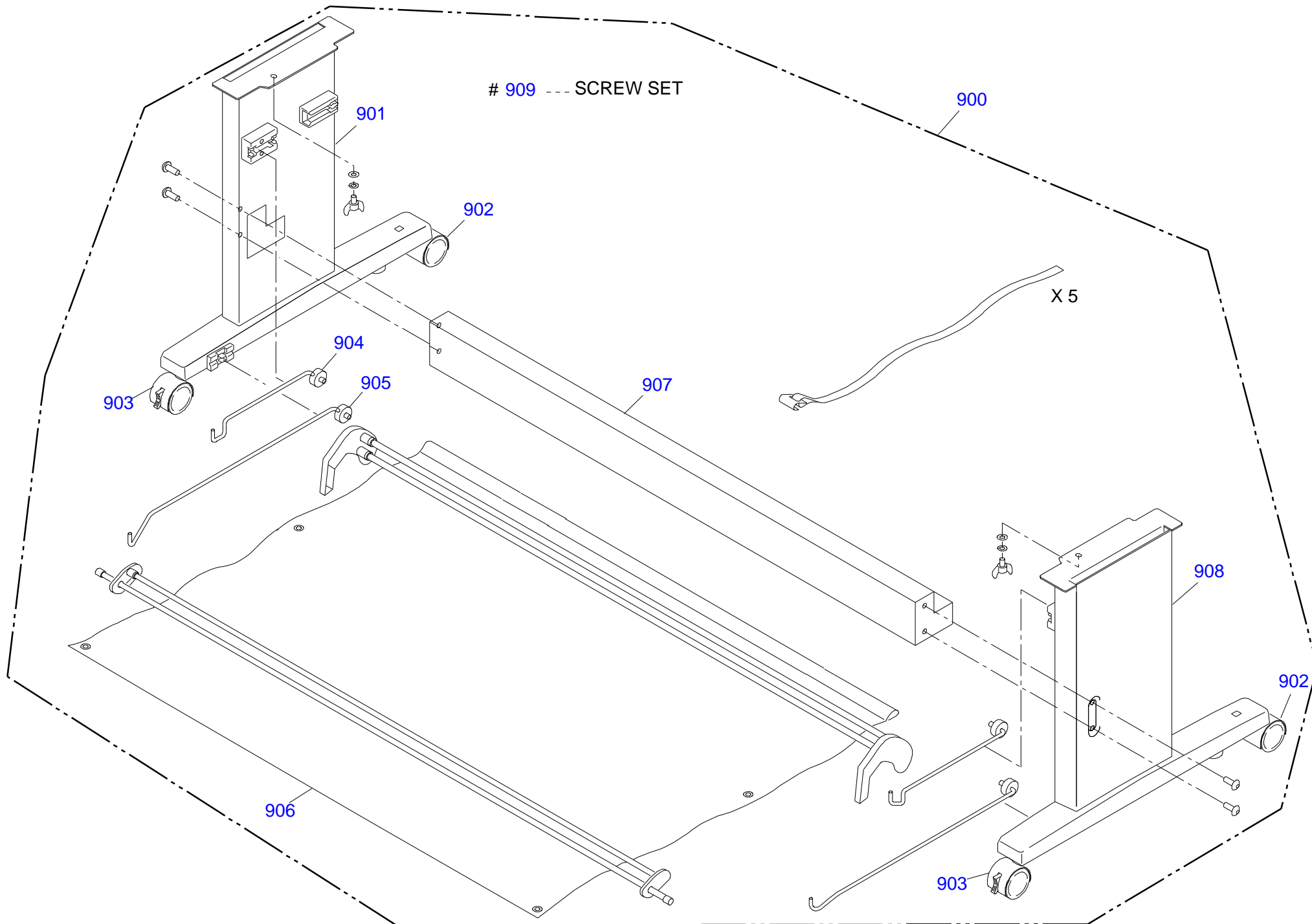

7.5 ASP List (Parts List)

7.5.1 ASP List for Stylus Pro 7600

Table 7-6. ASP List for Stylus Pro 7600

Ref No.	Part Name
100	L SIDE COVER ASSY.
101	I/H COVER ASSY.
102	I/H COVER ASSY.
103	PLASTIC STOPPER E5
104	FULONT COVER FUICRUM PIN L
105	FRONT COVER ASSY.
106	FRONT COVER SUPPLEMENT
107	ROLL TRAY L ASSY.
108	H TOP COVER ASSY.
109	CATCH
110	TOP COVER
111	DAMPER DISK(TOPCOVER)
112	UNDULATE WASHER(TOPCOVER)
113	PANEL UNIT ASSY.(OVERSEAS)
114	BRANK PANEL
115	LEVER BRIND CAP
116	PRSSURE LEVER KNOB
117	PANEL TAPE CABLE
118	ROLL TRAY R ASSY.
119	R SIDE COVER ASSY.
120	LABEL
121	LABEL
122	LABEL
123	LABEL
124	LABEL
125	LABEL
126	LABEL
127	LOGO PLATE 13X54

Table 7-6. ASP List for Stylus Pro 7600 (continued)

Ref No.	Part Name
128	LABEL
129	LABEL
130	LABEL
131	LABEL
150	FCC CLIP
151	RUBBER FOOT
152	FAN DUCT
153	VACUUM FAN
154	VACUUM FAN 2 CABLE
155	VACUUM FAN 1 CABLE
156	CR LOCKER ASSY.
157	P REAR SENSOR ASSY.
158	FLAT CLAMP(FCR-30-V0)
159	RECYCL CLAMP(RLWS-1515TL-V0)
160	RECYCL CLAMP
161	SILENT DUCT
200	BOARD ASSY.
201	GROUNDING PLATE
202	GUIDE
203	GROUNDING PLATE
500	MOUNTING PLATE
501	SCALE
502	TAPE
503	ENCODER FLANG
504	X REDUCTION BELT
505	BOARD ASSY.
506	SLIT GUIDE
507	PF ENCODER CABLE
508	PF MOTOR
509	PF MOTER CABLE 1 ASSY.
510	EDGE SADDLE
511	PARTITION PLATE

Table 7-6. ASP List for Stylus Pro 7600 (continued)

Ref No.	Part Name
550	CUTTER CAP
551	CUTTER SOLENOID SPRING
552	CUTTER SOLENOID ASSY.
553	CUTTER SPRING
554	P EDGE SENSOR ASSY.
555	EDGE SENSOR BASE ASSY.
556	FG CABLE
557	CR ENC ASSY.
558	CR LOCK KICKER
559	TILAP
560	H ADJUST LEVER B
561	H ADJUST LEVER
562	DAMPER STOPPER
563	DAMPER POSITION BOARD
564	PRINT HEAD
565	HEAD TAPE CABLE 1
566	HEAD TAPE CABLE 2
567	SLIDE GEAR
568	CONNECTING SCREW
569	O RING
570	DAMPER ASSY.
600	CR MOTOR
601	CR MOTOR CABLE ASSY.1
602	T FENCE SPRING
603	PRSSURE SPRING
604	T FENCE
605	P THICK SENSOR CABLE ASSY
606	PHOTO SENSOR
607	P THICK2 SENNSOR CABLE ASSY.
608	CR BELT
609	MINI CLAMP
610	CR DRIVE PULLEY ASSY.

Table 7-6. ASP List for Stylus Pro 7600 (continued)

Ref No.	Part Name
611	TENSION SPRING
612	PRESS LEVER SPRING
613	HD SLIDE ASSY.
614	CR HP CABLE ASSY.
615	CABLE CLAMP
616	EDGE CLAMP
617	PRESS IDLE GEAR
618	PRESS SHAFT TRAY
619	PRESS TRANSMISSION GEAR
620	PRESS LEVER
650	OUTLET ROLLER ASSY.
651	PAPER GUIDE L2
652	SUB PRATEN B
653	SUB PRATEN A
654	PARTITION PLATE P GUIDE L
655	PAETITION PLATE L
656	POROUS PAD CAP B
657	PROUSPAD C
658	PAETITION PLATE R ASSY.
659	TAPE
660	POROUS PAD
661	PAPER GUIDE WIRE
662	POROUS PAD
663	TAPE
664	PCB ASSY.I/C
665	MT FFC1
666	POROUS PAD ASSY.
667	SCREW MANUAL CUTTER
668	LABEL
669	LABEL
670	LABEL
671	LABEL

Table 7-6. ASP List for Stylus Pro 7600 (continued)

Ref No.	Part Name
672	LABEL
700	FLUSHING BOX ASSY.
701	PUMP MOTER JANCTION CABLE
702	TR CONNECTER
703	POROUS PAD
704	CLEANER
705	PUMP REDUCTION GEAR 1
706	POMP SHAFT STOPPER
707	PUMP REDUCTION GEAR 2
708	PG IDLE GEAR A
709	PG IDLE GEAR B
710	PUMP CAP ASSY.
711	MOTOR
712	CAP ASSY.
750	I/H INK FFC ASSY.
751	BOARD ASSY.
752	CSIC FFC 1
753	CLAMP
754	COVER SW CABLE ASSY.1
755	DETECTOR
756	CONNECTING SCREW
757	O RING
758	I/H LEVER SW CABLE ASSY.1
759	I/C LOCK LEVER KNOB
760	HOLDER ASSY.
761	FRAME ASSY.
762	FAN GEAR
763	LEVER
800	TUBE
801	TUBE
802	TUBE
803	TUBE

Table 7-6. ASP List for Stylus Pro 7600 (continued)

Ref No.	Part Name
804	TUBE
805	TUBE
806	TUBE
807	TUBE FILME
808	SUS SUPPORT
809	FILME
810	FLAT CORE(SSC-40-12)
811	FILME
812	CR FFC 1 ASSY.
813	BOARD ASSY.
850	FLANGE
851	ADAPTER
852	ROLL SHAFT
853	RETAINING RING(B150300611)
854	STOPPER SHAFT
855	FLANGE
856	LABEL
300	P/S BOARD ASSY.
301	DC CABLE ASSY

7.5.2 ASP List for Stylus Pro 9600

Table 7-7. ASP List for Stylus Pro 9600

Ref No.	Part Name
100	L SIDE COVER ASSY.
101	I/H COVER ASSY.
102	I/H COVER ASSY.
103	PLASTIC STOPPER E5
104	FULONT COVER FUICRUM PIN L
105	FRONT COVER ASSY.
106	FRONT COVER SUPPLEMENT
107	ROLL TRAY L ASSY.
108	H TOP COVER ASSY.
109	CATCH
110	TOP COVER
111	DAMPER DISK(TOPCOVER)
112	UNDULATE WASHER(TOPCOVER)
113	PANEL UNIT ASSY.(OVERSEAS)
114	BRANK PANEL
115	LEVER BRIND CAP
116	PRSSURE LEVER KNOB
117	PANEL TAPE CABLE
118	ROLL TRAY R ASSY.
119	R SIDE COVER ASSY.
120	LABEL
121	LABEL
122	LABEL
123	LABEL
125	LABEL
126	LABEL
127	LOGO PLATE 13X54
128	LABEL
129	LABEL
131	LABEL
150	FCC CLIP

Table 7-7. ASP List for Stylus Pro 9600 (continued)

Ref No.	Part Name
151	HANDLE
152	FAN DUCT
153	VACUUM FAN
154	VACUUM FAN1 CABLE ASSY.2
155	VACUUM FAN2 CABLE ASSY.2
156	CR LOCKER ASSY.
157	P REAR SENSOR ASSY.
158	FLAT CLAMP(FCR-30-V0)
159	RECYCL CLAMP(RLWS-1515TL-V0)
160	RECYCL CLAMP
161	SILENT DUCT
162	VACUUM FAN3 CABLE ASSY.2
200	BOARD ASSY.
201	GROUNDING PLATE
202	GUIDE
203	GROUNDING PLATE
500	MOUNTING PLATE
501	SCALE
502	TAPE
503	ENCODER FLANG
504	X REDUCTION BELT
505	BOARD ASSY.
506	SLIT GUIDE
507	PF ENCODER CABLE ASSY.2
508	PF MOTOR
509	PF MOTOR CABLE ASSY.2
510	EDGE SADDLE
511	PARTITION PLATE
550	CUTTER CAP
551	CUTTER SOLENOID SPRING
552	CUTTER SOLENOID ASSY.
553	CUTTER SPRING

Table 7-7. ASP List for Stylus Pro 9600 (continued)

Ref No.	Part Name
554	P EDGE SENSOR ASSY.
555	EDGE SENSOR BASE ASSY.
556	FG CABLE
557	CR ENC ASSY.
558	CR LOCK KICKER
559	TILAP
560	H ADJUST LEVER B
561	H ADJUST LEVER
562	DAMPER STOPPER
563	DAMPER POSITION BOAD
564	PRINT HEAD
565	HEAD TAPE CABLE 1
566	HEAD TAPE CABLE 2
567	SLIDE GEAR
568	CONNECTING SCREW
569	O RING
570	DAMPER ASSY.
600	CR MOTOR
601	CR MOTER CABLE ASSY.2
602	T FENCE SPRING
603	PRSSURE SPRING
604	SCALE
605	P THICK SENSOR CABLE ASSY
606	PHOTO SENSOR
607	P THICK2 SENNSOR CABLE ASSY.
608	CR FFC 1 ASSY.
609	MINI CLAMP
610	CR DRIVE PULLEY ASSY.
611	TENSION SPRING
612	PRESS LEVER SPRING
613	HD SLIDE ASSY.
614	CR HP CABLE ASSY.

Table 7-7. ASP List for Stylus Pro 9600 (continued)

Ref No.	Part Name
615	CABLE CLAMP
616	EDGE CLAMP
617	PRESS IDLE GEAR
618	PRESS SHAFT TRAY
619	PRESS TRANSMISSION GEAR
620	PRESS LEVER
650	OUTLET ROLLER ASSY.
651	PAPER GUIDE L2
652	SUB PRATEN B
653	SUB PRATEN A
654	PARTITION PLATE
655	PARTITION PLATE L
656	POROUS PAD CAP B
657	PROUSPAD C
658	PAETITION PLATE R ASSY.
659	TAPE
660	POROUS PAD
661	PAPER GUIDE WIRE
662	POROUS PAD
663	TAPE
664	PCB ASSY./C
665	M.T FFC2
666	POROUS PAD ASSY.
668	LABEL
669	LABEL
670	LABEL
671	LABEL
672	LABEL
700	FLUSHING BOX ASSY.
701	PUMP MOTER JANCTION CABLE
702	TR CONNECTER
703	POROUS PAD

Table 7-7. ASP List for Stylus Pro 9600 (continued)

Ref No.	Part Name
704	CLEANER
705	PUMP REDUCTION GEAR 1
706	POMP SHAFT STOPPER
707	PUMP REDUCTION GEAR 2
708	PG IDLE GEAR A
709	PG IDLE GEAR B
710	PUMP CAP ASSY.
711	MOTOR
712	CAP ASSY.
750	I/H INK FFC ASSY.
751	BOARD ASSY.
752	CSIC FFC 2
753	CLAMP
754	COVER SW CABLE ASSY.2
755	DETECTOR
756	CONNECTING SCREW
757	O RING
758	I/H LEVER SW CABLE ASSY.1
759	I/C LOCK LEVER KNOB
760	HOLDER ASSY.
761	FRAME ASSY.
762	FAN GEAR
763	LEVER
800	TUBE
801	TUBE
802	TUBE
803	TUBE
804	TUBE
805	TUBE
806	TUBE
807	TUBE FILME
808	SUS SUPPORT

Table 7-7. ASP List for Stylus Pro 9600 (continued)

Ref No.	Part Name
809	FILME
810	FLAT CORE(SSC-40-12)
811	FILME
812	CR FFC 1 ASSY.
813	BOARD ASSY.
850	FLANGE
851	ADAPTER
853	RETAINING RING(B150300611)
854	STOPPER SHAFT
855	FLANGE
856	LABEL
900	PACKING BOX ASSY.(W)
901	STAND L ASSY.
902	CASTER (NON STOPPER)
903	CASTER (STOPPER)
904	TRAY HOOK S ASSY.
905	TRAY HOOK L ASSY.
906	OUTLET TRAY
907	STAND STAY
908	STAND R ASSY.
909	SCREW ASSY.
300	P/S BOARD ASSY.
301	DC CABLE ASSY